

## G4 DIGITAL 16-CHANNEL DC INPUT INTEGRAL RACK

### Features

- > 16 optically-isolated inputs
- > Small footprint design, resulting in reduced mounting space
- > 4,000 V<sub>rms</sub> optical isolation
- > Compatible with Optomux® B1, Pamux® B5, and Mystic® B100 brain boards
- > Operating temperature: -30° C to 70° C



G4PB16J

### DESCRIPTION

The G4PB16J and G4PB16K DC input racks provide 16 channels of optically-isolated inputs for sensing on/off DC voltage levels by a B1, B5, or B100 brain board, or any ISA bus-compatible computer with an Opto 22 G4AC5 adapter card. Their compact size and design yields a substantial space and cost savings over other 16-channel I/O boards. All input channels are identical on each board and are ideal for applications that need to monitor several 4-16 VDC signals (model G4PB16J) or 16-28 VDC signals (model G4PB16K). On-board LED indicators display each channel's on/off status.

Typical applications for the integrated DC input racks include sensing the presence or absence of voltage from sources such as BCD devices, TTL level devices, thumbwheel switches, and barcode readers. Control connections are easily made to a 50-pin header connector. Barrier strips with screw terminals provide the field and rack power connections. The logic supply is fused with a 1A fuse.

The G4D32RS is a low-cost, high-I/O-capacity digital unit for the Opto 22 family of PC-based control products. Each I/O unit offers flexible, single-point, on/off control and latching for up to 32 digital I/O points. An easily accessible mounting rack makes field wiring simple to install. Communication connections are attached to a 3-wire terminal block and seamlessly integrate with other RS-485 remote brain boards, bricks, and modular controller systems. An onboard regulator ensures power protection to the modules and provides a regulated voltage source.

G4D32RS programming is accomplished with OptoControl or Cyrano, Opto 22's intuitive flowchart-based languages, or using a host computer and Opto 22's MysticWare software driver with the software language of your choice.

### MOUNTING

Mount the G4PB16J/K in an enclosure or to a panel using the mounting standoffs shown in the figure.

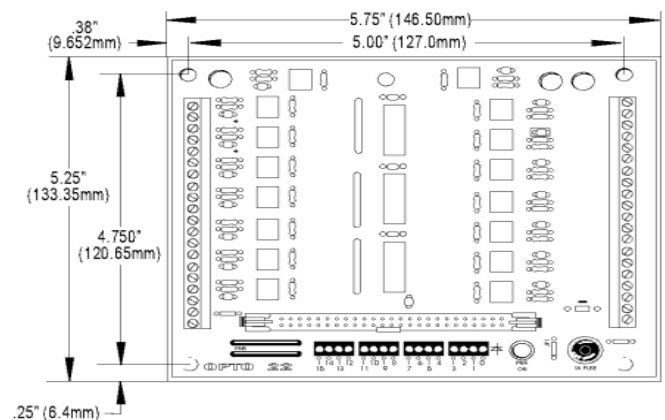

### Part Numbers

Part	Description
G4PB16J	G4 DC Input 4-16 VDC 16-channel Integral Rack
G4PB16K	G4 DC Input 16-28 VDC 16-channel Integral Rack

## SPECIFICATIONS

Table 1: General Specifications		Units	G4PB16J	G4PB16K
Input line voltage		VDC	4–16	16–28
Input current:				
@ Minimum voltage range		mA @ VDC	3.3, 4	3.4, 16
@ Maximum voltage range		mA @ VDC	16, 16	6.3, 28
Isolation:		VRMS		
Input-to-output		Continuous	4,000	4,000
Channel-to-channel		VRMS	300	300
Input-to-output capacitance		pF/channel	8	8
Turn-on-time		ms	2.5	3
Turn-off-time		ms	3.5	4.5
Logic supply voltage		VDC	4.5–6	4.5–6
Logic supply current		mA @ VDC	190, 5	190, 5
Temperature:				
Operating		° C	-30 to +70	-30 to +70
Storage		° C	-30 to +85	-30 to +85
Agency Approvals			UL, CE, CSA, RoHS, DFARS; UKCA	UL, CE, CSA, RoHS, DFARS; UKCA

Table 2: Channel Positions and Field Terminals		
Module Position	Control (Header Connector)	Field (Terminal Strip)
0	47	-0 and +0
1	45	-1 and -1
2	43	-2 and +2
3	41	-3 and +3
4	39	-4 and +4
5	37	-5 and +5
6	35	-6 and +6
7	33	-7 and +7
8	31	-8 and +8
9	29	-9 and +9
10	27	-10 and +10
11	25	-11 and +11
12	23	-12 and +12
13	21	-13 and +13
14	19	-14 and +14
15	17	-15 and +15

Even pins on the control connector are connected by etch to 5V return.

## CONNECTIONS

### CONNECTING FIELD WIRING

**Caution:** TURN OFF POWER to the G4PB16J/K before connecting or removing field wiring.

The figure below shows the location of the field wiring terminals on the G4PB16J/K mounting racks and the layout of the terminal points as they relate to each channel. Field wiring terminals accept up to 10 AWG wire. Refer to the figures on page 4 for schematics of the mounting racks.

Each channel has a positive (+) and negative (-) terminal. Connect the positive wire from your field device to the channel's positive terminal, and then connect the negative wire to the negative terminal. Table 1 on the following page lists the channel numbers, their respective field terminals, and pinouts to the header connector.

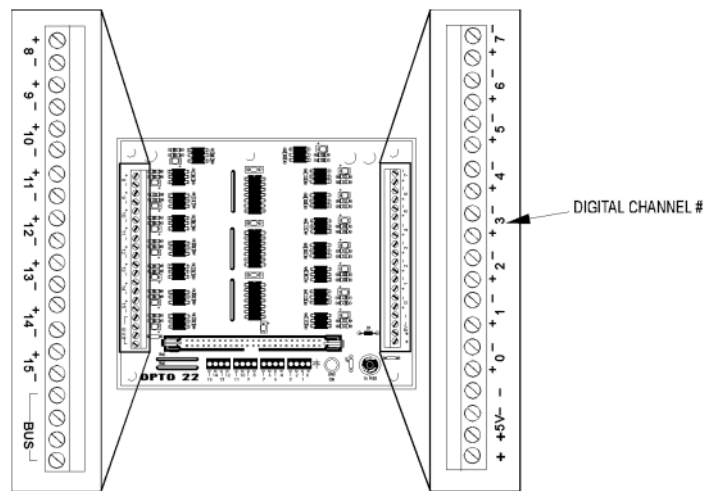

### BUS TERMINALS

The four terminals labeled "BUS" are tied together and are not electrically connected to anything else on the mounting rack. They may be used to provide additional terminals for bussing power, ground, or a common connection to multiple channels on the mounting rack.

## CONNECTIONS (CONTINUED)

### CONNECTING POWER TO THE G4PB16J/K

The G4PB16J/K racks require 190 mA at 5 VDC. These requirements are in addition to the power required by a brain board if you are using one.

Follow the instructions below to wire power to the mounting rack.

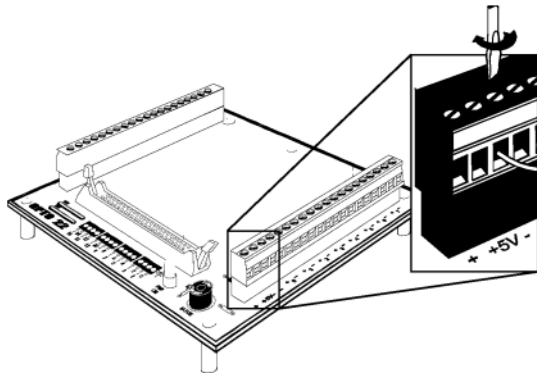

1. Verify that the power supply is turned off.
2. Make sure all power supply terminal block connections are completely open by turning the screws counter clockwise.
3. Prepare each power supply wire, being careful not to strip back the insulation too far.
4. Refer to the figure above and insert the power supply's +5V wire into one of the "+" terminals and the power supply's "-" wire into one of the "-" (GND) terminals.
5. Tighten each wire by turning the power terminal screw clockwise. Make sure the terminal block is clamping the wire and not the insulation.

## SCHEMATICS

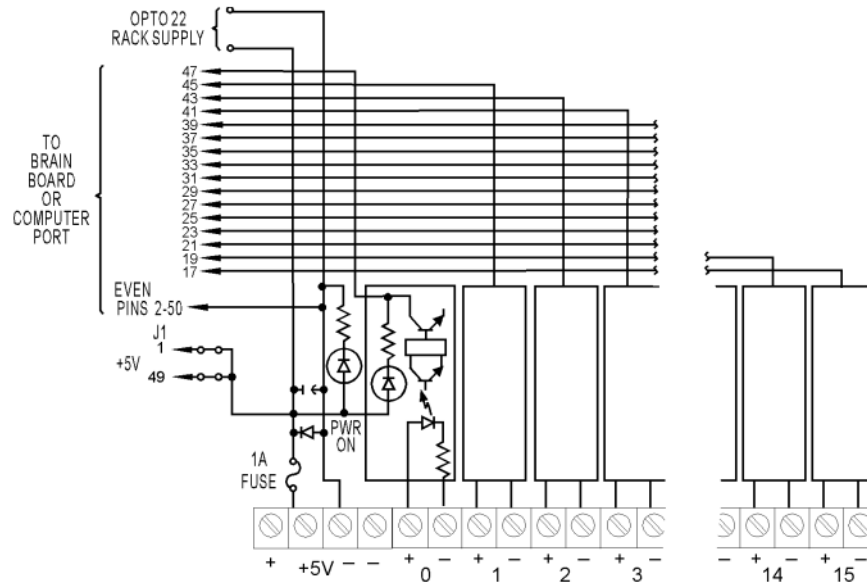

## ASSEMBLY ATTACHING A BRAIN BOARD OR PC CONNECTION

The G4PB16J/K boards work with B1, B5, or B100 brain boards. They can also be controlled directly by an IBM PC using an Opto 22 G4AC5 adapter card and a 50-pin ribbon cable.

Align the brain board or cable header connector with the header connector on the G4PB16J/K board as shown below. If you are connecting a 50-pin ribbon cable, the connector keys should match up. Firmly press the header connectors together until the locking tabs clamp down on the brain board or cable.

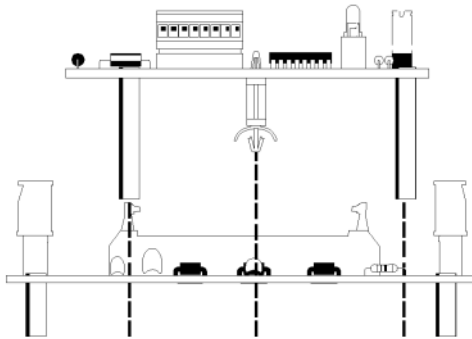
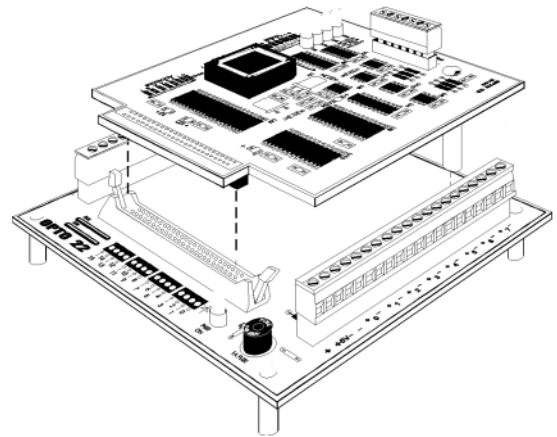

If you are attaching a B100 to a G4PB16J/K mounting rack, you must first attach a plastic, removable standoff to the brain board as shown in the figure above. Continue by installing the brain board to the mounting rack as described above and as shown in the figure to the left.

## LED INDICATORS

The figure to the right shows the LEDs found on the G4PB16J/K mounting racks. Three LED indicator groups on the mounting racks are used to indicate the status of each channel. A lit LED indicates the channel is on. An unlit LED indicates the channel is off.

A separate "PWR ON" LED is used to indicate that power is applied to the mounting rack. A lit LED indicates power is on. An unlit LED indicates power is off. The G4PB16L rack also has a "FUSE TESTER" LED indicator. A lit LED indicates the fuse inserted in the "FUSE TEST" fuse socket is good. An unlit LED indicates the fuse is bad and should not be used.

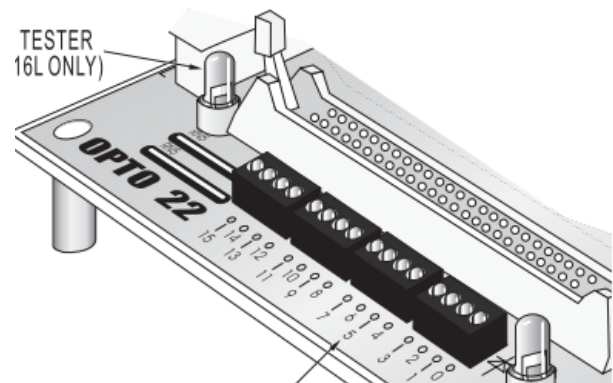

## PRODUCTS

Opto 22 develops and manufactures reliable, easy-to-use, open standards-based hardware and software products. Industrial automation, process control, remote monitoring, data acquisition, and industrial internet of things (IIoT) applications worldwide all rely on Opto 22.

### groov RIO®

groov RIO edge I/O offers a single, compact, PoE-powered industrial package with web-based configuration and IIoT software built in, support for multiple OT and IT protocols, and security features like a device firewall, data encryption, and user account control.

Standing alone, groov RIO connects to sensors, equipment, and legacy systems, collecting and securely publishing data from field to cloud. Choose a universal I/O model with thousands of possible field I/O configurations, with or without Ignition from Inductive Automation®, or a RIO EMU energy monitoring unit that reports 64 energy data values from 3-phase loads up to 600 VAC, Delta or Wye.

You can also use groov RIO with a Modbus/TCP master or as remote I/O for a groov EPIC system.

### groov EPIC® System

Opto 22's groov Edge Programmable Industrial Controller (EPIC) system gives you industrially hardened control with a flexible Linux®-based processor with gateway functions, guaranteed-for-life I/O, and software for your automation and IIoT applications.

#### groov EPIC Processor

The heart of the system is the groov EPIC processor. It handles a wide range of digital, analog, and serial functions for data collection, remote monitoring, process control, and discrete and hybrid manufacturing.

In addition, the EPIC provides secure data communications among physical assets, control systems, software applications, and online services, both on premises and in the cloud. No industrial PC needed.

Configuring and troubleshooting I/O and networking is easier with the EPIC's integrated high-resolution color touchscreen. Authorized users can manage the system locally on the touchscreen, on a monitor connected via the HDMI or USB ports, or on a PC or mobile device with a web browser.

#### groov EPIC I/O

groov I/O connects locally to sensors and equipment. Modules have a spring-clamp terminal strip, integrated wireway, swing-away cover, and LEDs indicating module health and discrete channel status. groov I/O is hot swappable, UL Hazardous Locations approved, and ATEX compliant.

#### groov EPIC Software

The groov EPIC processor comes ready to run the software you need:

- Programming: Choose flowchart-based PAC Control, CODESYS Development System for IEC61131-3 compliant programs, or secure shell access (SSH) to the Linux OS for custom applications
- Node-RED for creating simple IIoT logic flows from pre-built nodes
- Efficient MQTT data communications with string or Sparkplug data formats
- Multiple OPC UA server options
- HMI: groov View to build your own HMI viewable on touchscreen, PCs, and mobile devices; PAC Display for a

Windows HMI; Node-RED dashboard UI

- Ignition or Ignition Edge® from Inductive Automation (requires license purchase) with OPC-UA drivers to Allen-Bradley®, Siemens®, and other control systems, and MQTT communications

#### Older products

From solid state relays, to world-famous G4 and SNAP I/O, to SNAP PAC controllers, older Opto 22 products are still supported and working hard at thousands of installations worldwide. You can count on us for the reliability and service you expect, now and in the future.

## QUALITY

Founded in 1974, Opto 22 has established a worldwide reputation for high-quality products. All are made in the U.S.A. at our manufacturing facility in Temecula, California.

Because we test each product twice before it leaves our factory rather than testing a sample of each batch, we can afford to guarantee most solid-state relays and optically isolated I/O modules for life.

## FREE PRODUCT SUPPORT

Opto 22's California-based Product Support Group offers free technical support for Opto 22 products from engineers with decades of training and experience. Support is available in English and Spanish by phone or email, Monday–Friday, 7 a.m. to 5 p.m. PST.

Support is always available on our website, including [free online training](#) at OptoU, how-to [videos](#), [user's guides](#), the Opto 22 KnowledgeBase, and [OptoForums](#).

## PURCHASING OPTO 22 PRODUCTS

Opto 22 products are sold directly and through a worldwide network of distributors, partners, and system integrators. For more information, contact Opto 22 headquarters at **800-321-6786** (toll-free in the U.S. and Canada) or **+1-951-695-3000**, or visit our website at [www.opto22.com](http://www.opto22.com).

