

## SNAP D SERIES

### Features

- > Ideal for discrete control applications
- > Control directly or through an Opto 22 PC adapter card
- > Use panel or DIN-rail mounting
- > Modules snap into place

### DESCRIPTION

SNAP D-series racks are designed for discrete control applications and can accommodate 4, 6, 8, or 12 SNAP 4-channel digital modules. These racks use an industry-standard 50-pin header connector, which allows these racks to be used in a variety of applications.

The logic side of the I/O circuitry can be controlled directly or by using an Opto 22 PCIe-AC5 (PCI Express bus), PCI-AC5 (PCI bus) or G4AC5 or AC5 (ISA bus) PC adapter card.

In addition, the 4-module-position **SNAP-D4M** can be used with:

- A Raspberry Pi® and Opto 22's Digital I/O Carrier Board for Raspberry Pi (part number [OPTO-P1-40P](#))
- Opto 22's Classic brain boards, which use one of Opto 22's industry-standard protocols (*mistic*®, *Optomux*®, or *Pamux*®) to control the I/O and communicate either serially or in parallel

Field devices are wired directly to the top-mounted removable connectors on the SNAP I/O modules. The module and rack design allows modules to simply "snap" on and off the mounting rack.

SNAP racks use a retention-rail locking system that holds modules securely to the rack. Use two 4-40 by ½-inch standard machine screws to secure each module in position.

All SNAP racks offer panel mounting and the option of DIN-rail mounting. SNAP racks use a single 5 VDC power source.

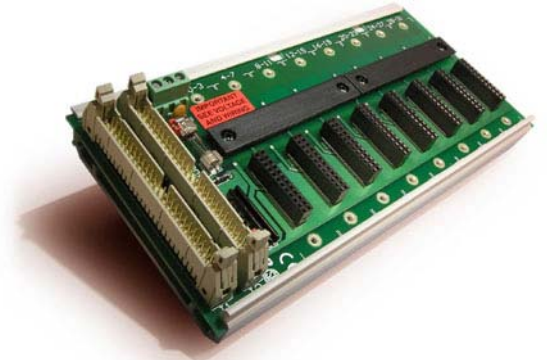

SNAP-D8M Rack

### Part Numbers

Part	Description
SNAP-D4M	4-module digital I/O rack
SNAP-D6M	6-module digital I/O rack
SNAP-D8M	8-module digital I/O rack
SNAP-D12M	12-module digital I/O rack
SNAP-CDBBDIN	Classic digital brain board DIN rail adapter
SNAP-FUSE1AB	1 amp fuse, 25-pack
SNAP-TEX-DRC-10	SNAP PAC rack DIN-rail adapter clip, 10-pack
SNAP-TEX-REC10N	Narrow end cap for SNAP PAC rack DIN-rail assemblies, 10-pack

## SPECIFICATIONS: SNAP-D4M (4 MODULE POSITION)

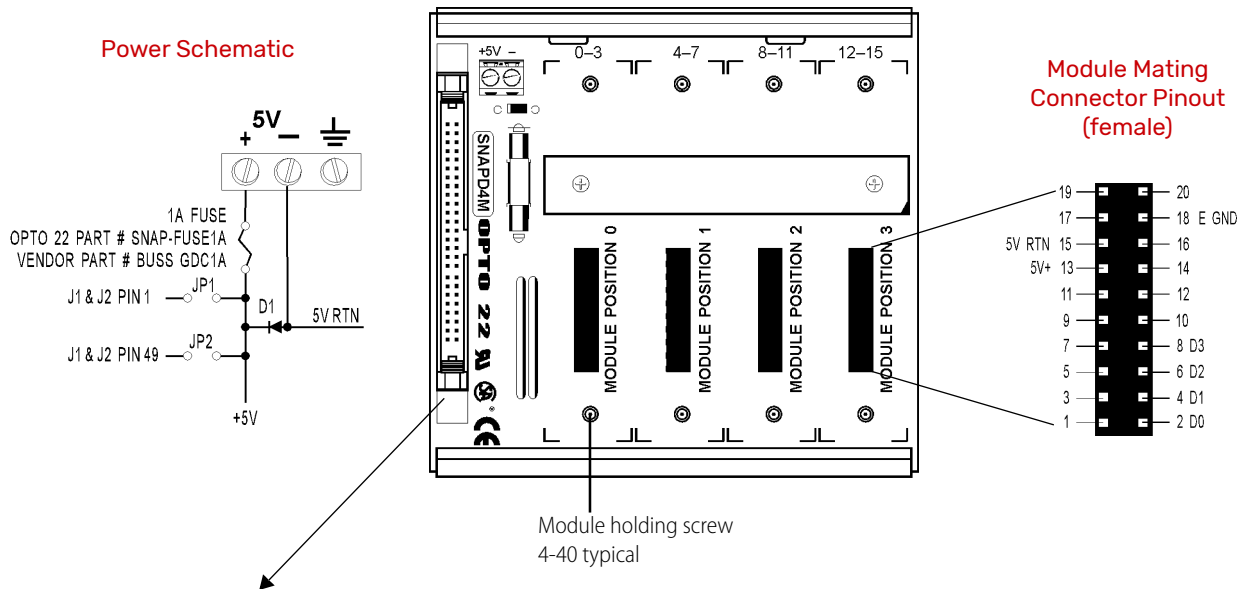

### Control Connector (50-pin male)

Module Position	Channel Position	J1 Control Connector
0	0	47
	1	45
	2	43
	3	41
	4	39
1	5	37
	6	35
	7	33
	8	31
2	9	29
	10	27
	11	25
	12	23
3	13	21
	14	19
	15	17

### Operating Requirements

Power Requirements	5 VDC ± 0.1 VDC @ 200 mA max. (700 mA with brain board)
Operating Temperature Range	0° to 70°C
Relative Humidity	95%, non-condensing
Agency Approvals	UL, DFARS

### Notes:

1. Even pins on control connectors are connected to 5V RTN.
2. Pin 1 of control connectors J1 and J2 is connected to +5V through jumper JP1.
3. Pin 49 of control connectors J1 and J2 is connected to +5V through jumper JP2.
4. For operation with PC adapter cards (PCIe-AC5, PCI-AC5, AC5, or G4AC5), remove jumpers JP1 and JP2.
5. Odd numbered pins 3 through 15 of control connectors are not used.

## SPECIFICATIONS: SNAP-D6M (6 MODULE POSITION)

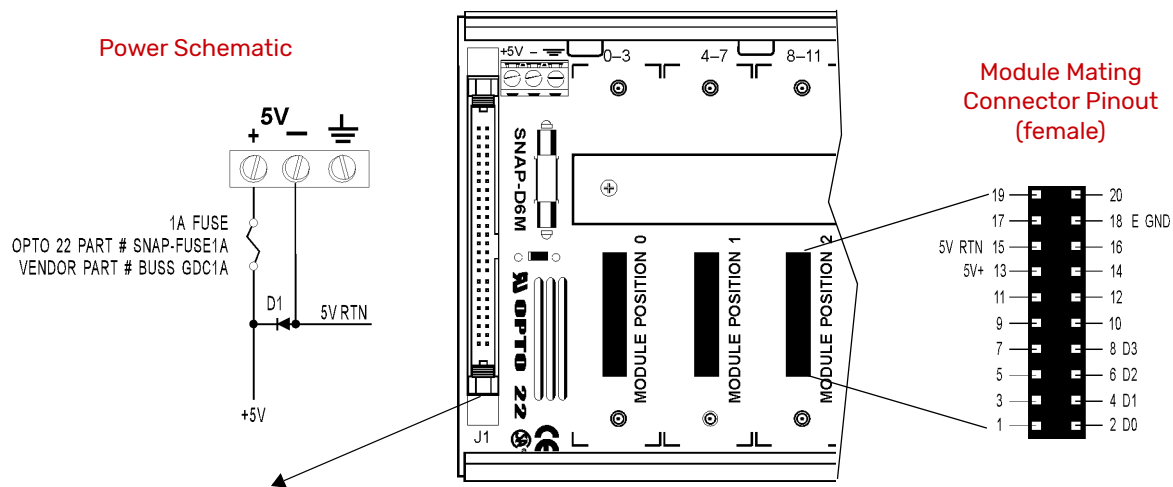

### Control Connector (50-pin male)

Module Position	Channel Position	J1 Control Connector
0	0	47
	1	45
	2	43
	3	41
	4	39
1	5	37
	6	35
	7	33
	8	31
2	9	29
	10	27
	11	25
	12	23
3	13	21
	14	19
	15	17
	16	15
4	17	13
	18	11
	19	9
5	20	7
	21	5
	22	3
	23	1

### Operating Requirements

Power Requirements	5 VDC $\pm$ 0.1 VDC @ 300 mA max.
Operating Temperature Range	0° to 70°C
Relative Humidity	95%, non-condensing
Agency Approvals	UL, CE, RoHS, DFARS; UKCA

### Notes:

1. Even pins on control connectors are connected to 5V RTN.
2. SNAP-D6M and SNAP-D12M are designed to interface with PC adapter cards (PCIe-AC5, PCI-AC5, AC5, or G4AC5). They are not compatible with brain boards, because there is no power to the control connector.
3. Pin 49 - "no" connection.

## SPECIFICATIONS: SNAP-D8M (8 MODULE POSITION)

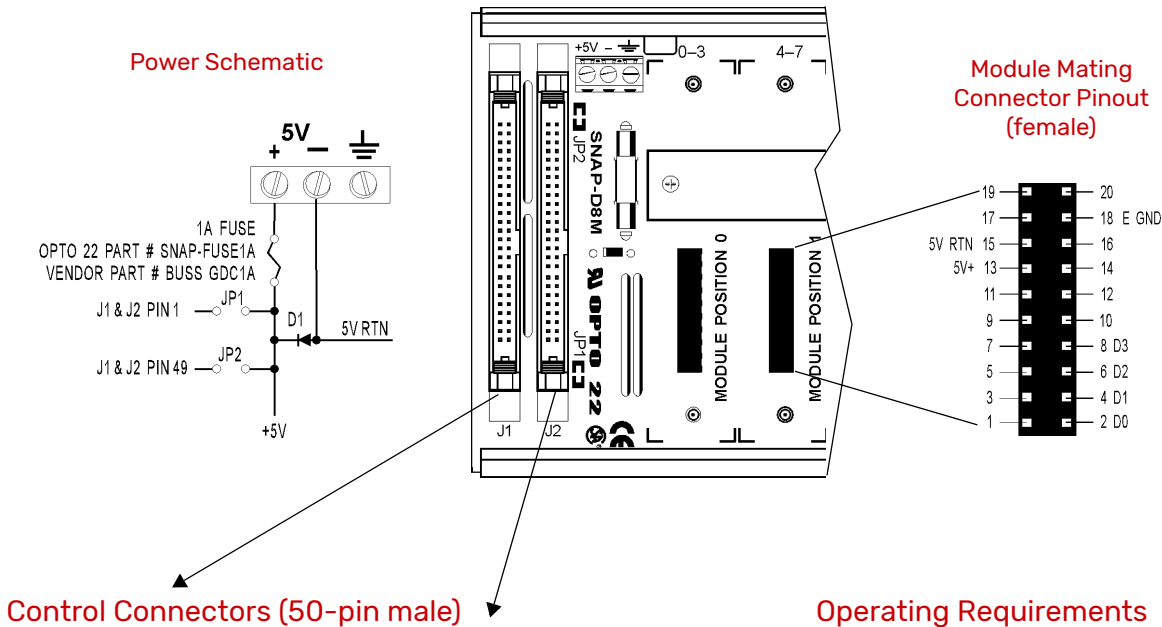

Module Position	Channel Position	J1 Control Connector	Module Position	Channel Position	J2 Control Connector
0	0	47	4	16	47
	1	45		17	45
	2	43		18	43
	3	41		19	41
	4	39		20	39
1	5	37	5	21	37
	6	35		22	35
	7	33		23	33
	8	31		24	31
2	9	29	6	25	29
	10	27		26	27
	11	25		27	25
	12	23		28	23
	13	21		29	21
3	14	19	7	30	19
	15	17		31	17

### Operating Requirements

Power Requirements	5 VDC ± 0.1 VDC @ 400 mA max.
Operating Temperature Range	0° to 70°C
Relative Humidity	95%, non-condensing
Agency Approvals	UL, DFARS

### Notes:

1. Even pins on control connectors are connected to 5V RTN.
2. Pin 1 of control connectors J1 and J2 is connected to +5V through jumper JP1.
3. Pin 49 of control connectors J1 and J2 is connected to +5V through jumper JP2.
4. For operation with PC adapter cards (PCIe-AC5, PCI-AC5, AC5, or G4AC5), remove jumpers JP1 and JP2.
5. Odd numbered pins 3 through 15 of control connectors are not used.

## SPECIFICATIONS: SNAP-D12M (12 MODULE POSITION)

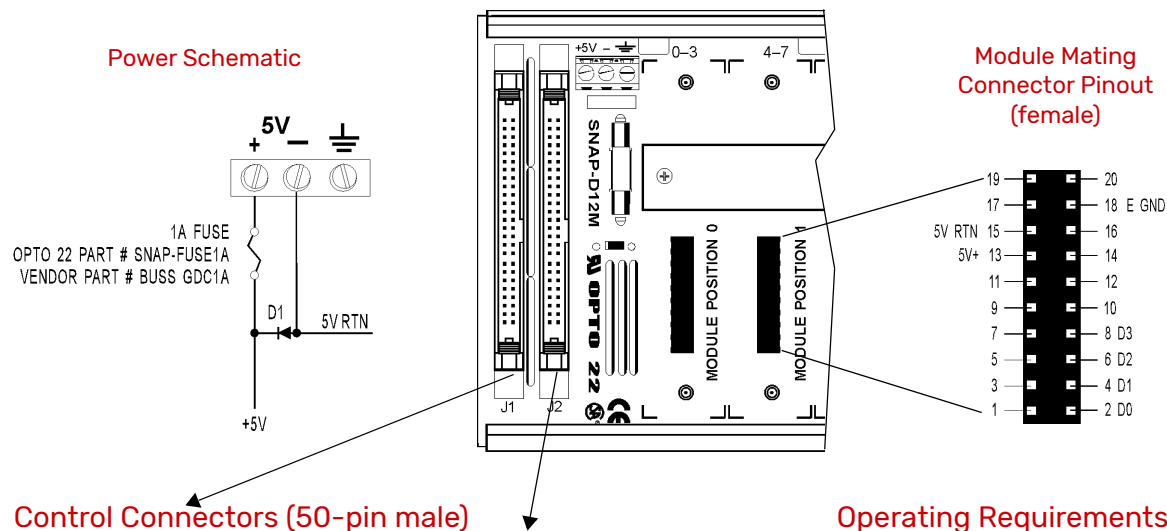

### Control Connectors (50-pin male)

Module Position	Channel Position	J1 Control Connector	Module Position	Channel Position	J2 Control Connector
0	0	47	6	0	47
	1	45		1	45
	2	43		2	43
	3	41		3	41
1	4	39	7	4	39
	5	37		5	37
	6	35		6	35
	7	33		7	33
2	8	31	8	8	31
	9	29		9	29
	10	27		10	27
	11	25		11	25
3	12	23	9	12	23
	13	21		13	21
	14	19		14	19
	15	17		15	17
4	16	15	10	16	15
	17	13		17	13
	18	11		18	11
	19	9		19	9
5	20	7	11	20	7
	21	5		21	5
	22	3		22	3
	23	1		23	1

### Operating Requirements

Power Requirements	5 VDC ± 0.1 VDC @ 1200mA max.
Operating Temperature Range	0° to 70°C
Relative Humidity	95%, non-condensing
Agency Approvals	UL, CE, RoHS, DFARS; UKCA

### Notes

1. Even pins on control connectors are connected to 5V RTN.
2. SNAP-D6M and SNAP-D12M are designed to interface with PC adapter cards (PCIe-AC5, PCI-AC5, AC5, or G4AC5). They are not compatible with brain boards, because there is no power to the control connector.

## DIMENSIONAL DRAWING

Front View (when Mounted)—All Models

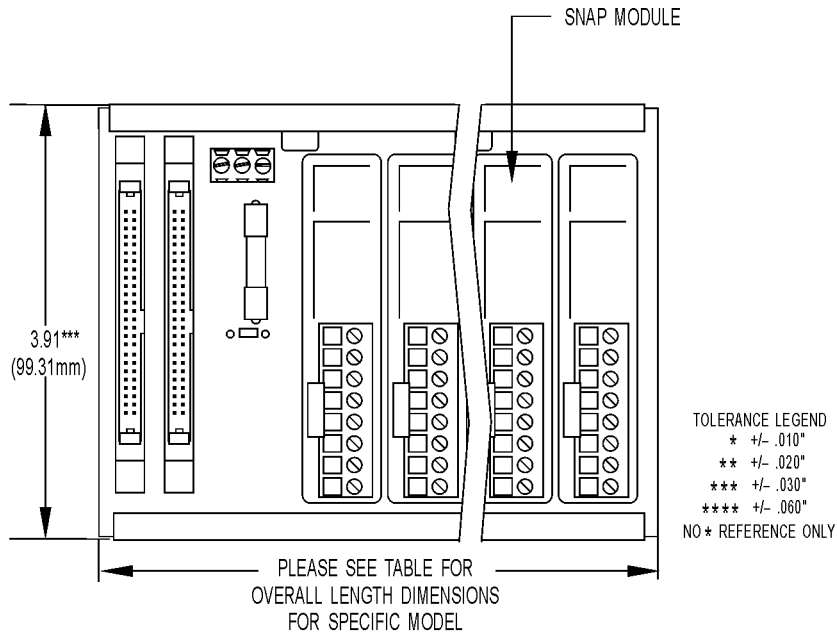

### Overall Length Dimension (All Models)

Part Numbers	Description	Length (inches)	Length (mm)
SNAP-D4M	4-module rack	4.19	106.43
SNAP-D6M	6-module rack	5.74	145.8
SNAP-D8M	8-module rack	7.74	196.6
SNAP-D12M	12-module rack	10.74	272.8

## DIMENSIONAL DRAWING

Right Side View (with Customer-supplied DIN-Rail Option)—All Models

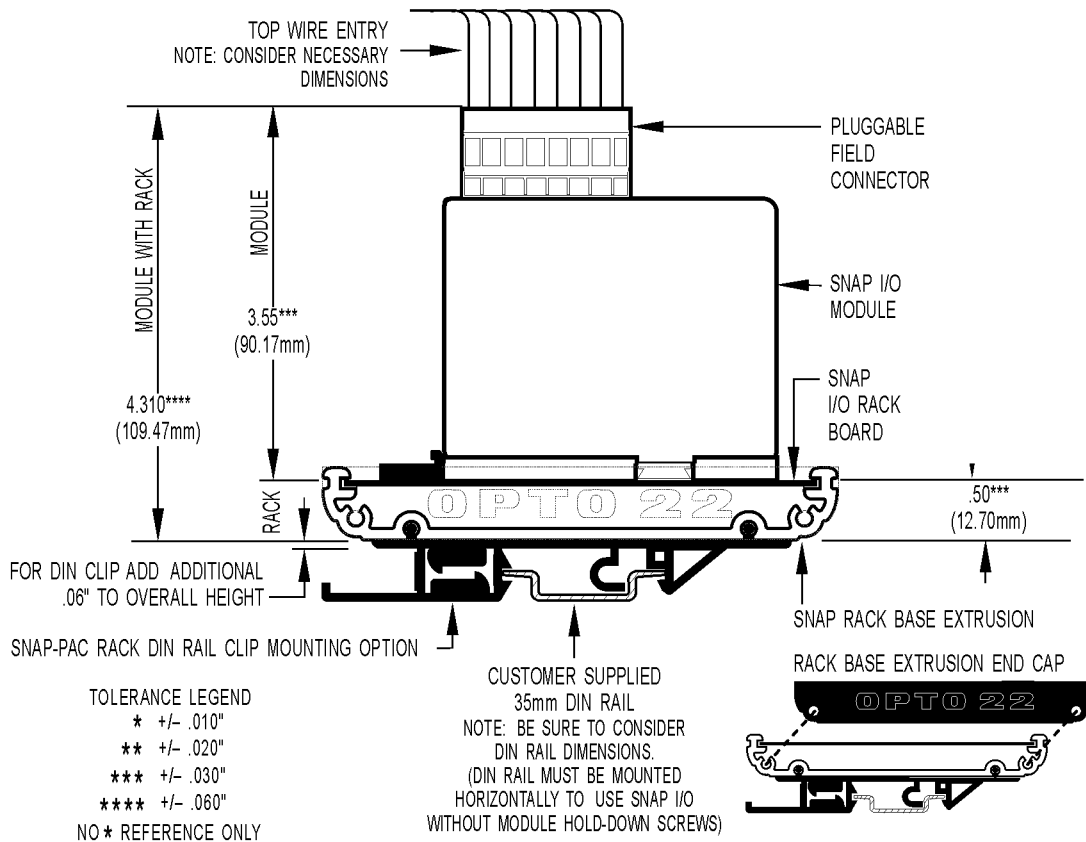

## DIMENSIONAL DRAWING

Typical Plain View of SNAP Mounting Extrusion—All Models

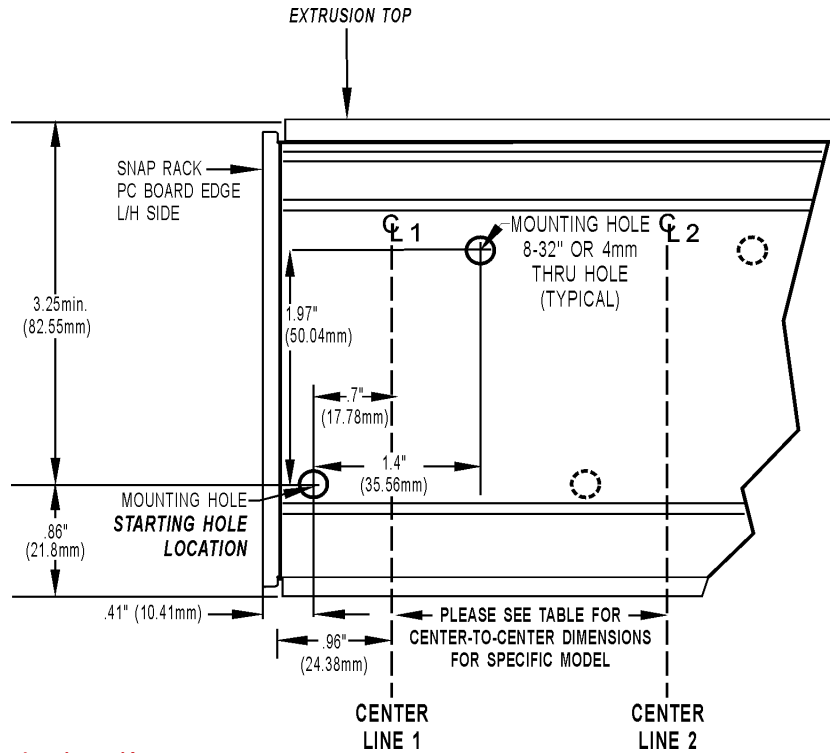

### General Mounting Instructions

The SNAP rack assembly should be mounted horizontally, as shown in diagram, if not using module hold-down screws.

#### Preferred Method: Template (product on site)

1. Use SNAP rack mounting extrusion as template.
2. Be sure to use drawing to determine required product and option clearances.

#### Alternate Method: Prefabrication of Panels (no product on site)

1. Mounting holes are in sets of two located on lower left and upper right, with respect to a centerline (CL).
2. Using the drawing, determine CL1 mounting hole positions. (CL1 is located on the left side of all SNAP rack mounting extrusions.)
3. Use the center-to-center length specification table to determine offset between centerlines and number of centerline positions for each model.
4. Repeat process for each centerline position.
5. Dimensions shown in drawing apply to all models.

#### Center-to-Center Length (All Models)

Part Numbers	Description	Center-to-Center Length (inches)	# of Center Positions
SNAP-D4M	4-module rack	1.98	2
SNAP-D6M	6-module rack	3.53	2
SNAP-D8M	8-module rack	5.53	2
SNAP-D12M	12-module rack	4.26	3



## PRODUCTS

Opto 22 develops and manufactures reliable, easy-to-use, open standards-based hardware and software products. Industrial automation, process control, remote monitoring, data acquisition, and industrial internet of things (IIoT) applications worldwide all rely on Opto 22.

### groov RIO®

groov RIO edge I/O offers a single, compact, PoE-powered industrial package with web-based configuration and IIoT software built in, support for multiple OT and IT protocols, and security features like a device firewall, data encryption, and user account control.

Standing alone, groov RIO connects to sensors, equipment, and legacy systems, collecting and securely publishing data from field to cloud. Choose a universal I/O model with thousands of possible field I/O configurations, with or without Ignition from Inductive Automation®, or a RIO EMU energy monitoring unit that reports 64 energy data values from 3-phase loads up to 600 VAC, Delta or Wye.

You can also use groov RIO with a Modbus/TCP master or as remote I/O for a groov EPIC system.

### groov EPIC® System

Opto 22's groov Edge Programmable Industrial Controller (EPIC) system gives you industrially hardened control with a flexible Linux®-based processor with gateway functions, guaranteed-for-life I/O, and software for your automation and IIoT applications.

### groov EPIC Processor

The heart of the system is the groov EPIC processor. It handles a wide range of digital, analog, and serial functions for data collection, remote monitoring, process control, and discrete and hybrid manufacturing.

In addition, the EPIC provides secure data communications among physical assets, control systems, software applications, and online services, both on premises and in the cloud. No industrial PC needed.

Configuring and troubleshooting I/O and networking is easier with the EPIC's integrated high-resolution color touchscreen. Authorized users can manage the system locally on the touchscreen, on a monitor connected via the HDMI or USB ports, or on a PC or mobile device with a web browser.

### groov EPIC I/O

groov I/O connects locally to sensors and equipment. Modules have a spring-clamp terminal strip, integrated wireway, swing-away cover, and LEDs indicating module health and discrete channel status. groov I/O is hot swappable, UL Hazardous Locations approved, and ATEX compliant.

### groov EPIC Software

The groov EPIC processor comes ready to run the software you need:

- Programming: Choose flowchart-based PAC Control, CODESYS Development System for IEC61131-3 compliant programs, or secure shell access (SSH) to the Linux OS for custom applications
- Node-RED for creating simple IIoT logic flows from pre-built nodes
- Efficient MQTT data communications with string or Sparkplug data formats
- HMI: groov View to build your own HMI viewable on touchscreen, PCs, and mobile devices; PAC Display for a Windows HMI; Node-RED dashboard UI
- Ignition or Ignition Edge® from Inductive Automation (requires license purchase) with OPC-UA drivers to Allen-Bradley®, Siemens®, and other control systems, and MQTT communications



### Older products

From solid state relays, to world-famous G4 and SNAP I/O, to SNAP PAC controllers, older Opto 22 products are still supported and working hard at thousands of installations worldwide. You can count on us for the reliability and service you expect, now and in the future.

## QUALITY

Founded in 1974, Opto 22 has established a worldwide reputation for high-quality products. All are made in the U.S.A. at our manufacturing facility in Temecula, California.

Because we test each product twice before it leaves our factory rather than testing a sample of each batch, we can afford to guarantee most solid-state relays and optically isolated I/O modules for life.

## FREE PRODUCT SUPPORT

Opto 22's California-based Product Support Group offers free technical support for Opto 22 products from engineers with decades of training and experience. Support is available in English and Spanish by phone or email, Monday–Friday, 7 a.m. to 5 p.m. PST.

Support is always available on our website, including [free online training](#) at OptoU, how-to [videos](#), [user's guides](#), the Opto 22 KnowledgeBase, and [OptoForums](#).

## PURCHASING OPTO 22 PRODUCTS

Opto 22 products are sold directly and through a worldwide network of distributors, partners, and system integrators. For more information, contact Opto 22 headquarters at **800-321-6786** (toll-free in the U.S. and Canada) or **+1-951-695-3000**, or visit our website at [www.opto22.com](http://www.opto22.com).