

SNAP PAC R-SERIES CONTROLLERS

Features

- > Rack-mounted industrial controller with I/O processor included.
- > Two independent 10/100 Mbps Ethernet network interfaces
- > Multiple protocol support: TCP/IP, HTTP/HTTPS, EtherNet/IP™, Modbus®/TCP, SNMP, SMTP, FTP, and OptoMMP™
- > IIoT and developer ready with a RESTful API to securely access data
- > One RS-232 port with handshaking, suitable for modem communication using PPP
- > MicroSD card slot for removable data storage
- > Full-featured control and HMI software included with purchase
- > UL approved

DESCRIPTION

The affordable and compact SNAP PAC R-series programmable automation controllers provide powerful, real-time control and communication to meet your industrial control, monitoring, Industrial Internet of Things (IIoT), and data acquisition needs. Part of the Opto 22 SNAP PAC System™, the R-series PAC is a rack-mounted, industrially hardened unit that can handle multiple tasks involving digital and analog control, serial string handling, communication, and enterprise connectivity.

Used with the included PAC Project Basic software suite (or PAC Project Professional, purchased separately), the Ethernet-based SNAP PAC R-series controller runs control programs written in Opto 22's PAC Control™ software. It can monitor and control a wide range of devices and equipment wired to the I/O on its own rack and to I/O on distributed racks equipped with SNAP PAC EB-series brains or *groov RIO edge I/O* modules. Alternatively, the R-series controller can be used as a slave to a larger controller, either a *groov EPIC* edge programmable industrial controller, a SNAP PAC S-series standalone industrial controller, or a SoftPAC™ software-based controller for PC-based control.

SNAP PAC R-series controllers include a RESTful API (representational state transfer application program interface), so you can use the language of your choice to securely access controller tag data and use it for business purposes.

SNAP PAC R-series controllers are well suited in process control, discrete manufacturing, or hybrid industries and applications.

Several models are available:

- **SNAP-PAC-R1, SNAP-PAC-R1-FM, and SNAP-PAC-R1-B** each control a mix of SNAP analog, digital (both 4-channel and



SNAP-PAC-R1 controller

high-density), and serial modules. Full digital functions include high-speed counting; quadrature counting; and pulse, period, and frequency measurement. The -FM model is Factory Mutual approved. The -B model is designed to mount on SNAP B-series racks so that older I/O units can be easily upgraded to a newer controller.

- **SNAP-PAC-R2** and **SNAP-PAC-R2-FM** also control a mix of SNAP analog, 4-channel and high-density digital, and serial modules. High-speed digital functions are not included. The -FM model is Factory Mutual approved.

Built-in functions and comparisons of the SNAP-PAC-R1 and SNAP-PAC-R2 are shown in the table on [page 8](#).

Part Numbers

Part	Description
SNAP-PAC-R1	Analog/digital/serial rack-mounted controller with two Ethernet ports and high-speed digital functions, RESTful API
SNAP-PAC-R1-B	Analog/digital/serial rack-mounted controller with two Ethernet ports and high-speed digital functions, RESTful API, for B-series racks, Factory Mutual approved
SNAP-PAC-R1-FM	Analog/digital/serial rack-mounted controller with two Ethernet ports and high-speed digital functions, RESTful API, Factory Mutual approved
SNAP-PAC-R2	Analog/simple digital/serial rack-mounted controller with two Ethernet ports, RESTful API
SNAP-PAC-R2-FM	Analog/simple digital/serial rack-mounted controller with two Ethernet ports, RESTful API, Factory Mutual approved

Ethernet Communication

All SNAP PAC R-series controllers communicate over standard 10/100 Mbps Ethernet networks and can be attached to an existing network. The controllers can also be used in an independent control network built with standard, off-the-shelf Ethernet hardware.

SNAP PAC R-series controllers include two 10/100 Mbps Ethernet interfaces for networking to Ethernet hosts and to other I/O units. These interfaces support Auto MDI-X, which means you can use a standard straight-through Ethernet cable; a crossover cable is not needed for direct connection to a PC. The two independent Ethernet ports have separate IP addresses that can be used with PAC Project™ Professional software to set up redundant network links to safeguard the availability and reliability of an I/O system, or to segment a control system's network from the enterprise LAN.

Supported protocols over Ethernet include EtherNet™/IP, Modbus®/TCP, SMTP, SNMP, FTP, and OptoMMP.

Serial Communication

SNAP PAC R-series controllers provide an RS-232 serial link to support Point-to-Point Protocol (PPP) modem connections—for creating TCP/IP networks over serial or PSTN (Public Switched Telephone Network) lines—as well as remote serial device communication.

The RS-232 serial interface supports either a modem connection using PPP or general-purpose communication with serial devices, allowing you to send and receive data from a serial device connected directly to the controller. For additional serial interfaces, you can add one or more SNAP serial communication modules on the rack.

NOTE: The R-series controller does not include an RS-485 port and cannot be used to control Opto 22 serial I/O processors, such as the SNAP PAC SB-series brains. Use an S-series controller for serial brains.

I/O Mounting Racks

SNAP PAC R-series controllers must be connected to the appropriate rack to avoid damage to the controller. Both the SNAP-PAC-R1 and R2 are designed to work with SNAP PAC mounting racks, which are available with 4, 8, 12, or 16 positions for Opto 22 SNAP I/O modules. Part numbers are SNAP-PAC-RCK4, SNAP-PAC-RCK8, SNAP-PAC-RCK12, and SNAP-PAC-RCK16. Factory Mutual-approved versions of these racks, with part numbers ending in -FM, are also available.

Ethernet PAC for Legacy I/O Racks

The **SNAP-PAC-R1-B** is a PAC-R1 for use with older SNAP B-series racks (only B-series racks with a B in the part number; not the SNAP-D64RS rack). This PAC provides an upgrade path from legacy brains and rack-mounted controllers such as the SNAP-B3000-ENET or

SNAP-UP1-ADS that use B-series racks. See the [SNAP B-series Racks data sheet](#) (form 0784) for more information on racks.

The SNAP-PAC-R1-B uses the same firmware and has the same functionality as the SNAP-PAC-R1, except that 4-channel digital modules can be placed only in slots 0-7 due to limitations of the rack.

This PAC is Factory Mutual approved.

SNAP I/O

The SNAP PAC R-series controllers support all [SNAP I/O modules](#) available on our website. SNAP digital I/O modules contain four input or output points, and SNAP high-density digital modules contain 16 or 32 input or output points. SNAP analog modules contain 2 to 32 points, depending on the module.

Forward Compatibility

SNAP PAC R-series controllers are compatible with newer [groov EPIC](#) processors and [groov RIO](#) edge I/O units, which add industrial internet of things (IIoT) data communications and cybersecurity features to your system. Both [groov EPIC](#) and [groov RIO](#) can be used as I/O units with an R-series controller. If you already have R-series controllers, you can use them as I/O units with a [groov EPIC](#) system.

Depending on your application, consider purchasing a [groov RIO](#) edge I/O module or a [groov EPIC](#) processor instead of a SNAP PAC R-series controller.

- If you don't need traditional control, [groov RIO](#) offers significant security features, thousands of I/O options, built-in IIoT software, and lower cost, in a small footprint suited for hazardous industrial areas.
- For control, [groov EPIC](#) provides system security, better performance, control programming options, built-in IIoT software, and much more.

For more information, see [groov RIO](#) and the [groov EPIC system](#) on our website, or contact our pre-sales engineers.

Software

SNAP PAC controllers use Opto 22's **PAC Project** Microsoft® Windows®-compatible automation software for programming, human-machine-interface (HMI) development, and OPC connectivity.

Two versions of PAC Project are available on our website, www.opto22.com: PAC Project Basic is free to download; PAC Project Professional is available for purchase and download.

- **PAC Project Basic** includes PAC Control™ for developing control programs, PAC Display™ for creating operator interfaces, and PAC Manager™ configuration software.
- **PAC Project Professional** adds expanded versions of PAC Control and PAC Display plus a SoftPAC software-based

controller for PC-based control, OptoOPCServer™ software for exchanging data with OPC 2.0-compliant client software applications, and OptoDataLink™ for exchanging SNAP PAC System data with databases (including Microsoft SQL Server, Microsoft Access, and MySQL), text files, and email systems).

You can also purchase PAC Control Professional, PAC Display Professional, SoftPAC, OptoOPCServer, and OptoDataLink separately. For details, see the [PAC Project Data Sheet](#) (form 1699).

PAC Control Basic is a graphical, flowchart-based programming tool for machine control and process applications. Using PAC Control, you create, download, and run strategies on a SNAP PAC or groov EPIC controller. In addition to flowchart programming with subroutine capability, PAC Control includes a powerful, built-in scripting language based on C and other procedural languages.

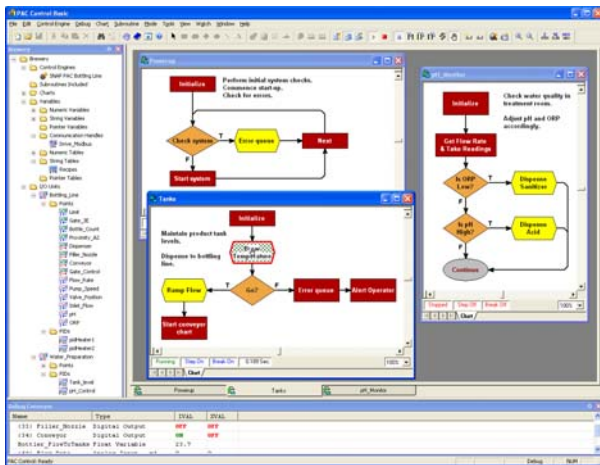

PAC Control Professional adds the ability to import legacy OptoControl strategies, support for older *mistic*™ serial I/O units, and support for the dual independent Ethernet ports on a SNAP PAC controller.

The number of PAC Control flowcharts that can simultaneously run depends on the controller, but the PAC Control strategy can contain a much larger number of flowcharts. The total number of flowcharts is limited only by the memory available for strategy storage.

PAC Display Basic is an intuitive HMI package for building operator interfaces, or *projects*, for communicating with a SNAP PAC controller. PAC Display offers a full-featured HMI including alarming, trending, and a built-in library of 3,000 industrial automation graphics.

PAC Display Professional adds the ability to import projects created in OptoDisplay, part of the legacy Opto 22 FactoryFloor® software suite, and using redundant Ethernet communication links on SNAP PAC controllers. PAC Display Professional can also connect to Ethernet-based FactoryFloor controllers running OptoControl strategies.

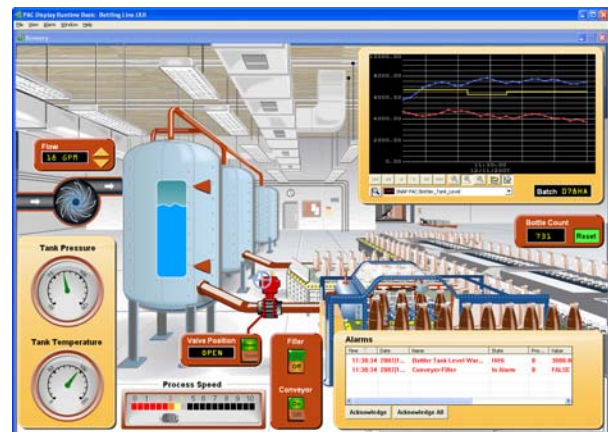

SoftPAC is a software-based programmable automation controller (PAC) designed for PC-based control. Programmed just like an Opto 22 hardware controller, SoftPAC runs your PAC Control strategy independently on an embedded or standalone PC. SoftPAC takes advantage of a PC's speed and file capabilities for applications requiring extended file storage, frequent access to files, or math-intensive processes.

OptoOPCServer is a fast, efficient OPC 2.0-compliant server for communicating with many Opto 22 products, including SNAP PAC controllers and I/O units, plus legacy Opto 22 Ethernet-based controllers and I/O. Using OptoOPCServer, you can consolidate data from all these Opto 22 systems into the OPC client software of your choice, such as third-party HMI and data acquisition packages, and custom software applications you create with tools such as Visual C++®.

OptoDataLink is a software application that makes it easy to share data from the SNAP PAC System with commonly used databases, including Microsoft SQL Server, Microsoft Access, and MySQL, as well as text files. The I/O points and strategy variables already created in your PAC Control strategy are automatically available for OptoDataLink to use for data exchange.

PAC Manager is a utility application for assigning IP addresses to SNAP PAC controllers and brains, reading or changing basic controller configuration, and configuring and testing I/O.

Software Availability

PAC Project Basic is included with SNAP PAC controllers and is a free download from the Opto 22 website.

PAC Project Professional is available for purchase on our website. To get it immediately, you can buy and download the software and documentation from the Opto 22 website at www.opto22.com.

You can also separately purchase PAC Control Professional, PAC Display Professional, SoftPAC, OptoOPCServer, and OptoDataLink as needed.

RESTful API

Your SNAP PAC controller's built-in RESTful application program interface (API) lets you exchange data easily using the architecture of the internet and the language of your choice.

You can query PAC Control strategy tags with HTTPS (Basic Auth) using your favorite programming language—PHP, .NET, Node.js,

Python, or others. Tag data from I/O points and controller variables is returned as JSON.

You can set up authentication keys with permissions for either read-only or read-write, as necessary for your application. The RESTful API is included in SNAP PAC firmware R9.5a and PAC Project 9.5 (or higher). See developer.opto22.com for complete information.

SPECIFICATIONS

Specifications are continued on the following page.

Processor	200 MHz 32-bit ColdFire® 5475 with integrated floating-point unit (FPU)
Memory	
Total RAM	16 MB (5 MB available for PAC Control strategy and 2 MB for file storage)
Battery-backed RAM	2 MB (1 MB available for PAC Control strategy)
Flash	8 MB (3.25 MB available for PAC Control strategy; 384 KB available for file storage)
Removable storage	(Models with manufacture dates of November 2008 and newer. Requires firmware R9.4a or higher and loader R6.1a or higher) MicroSD card slot: supports microSD or microSDHC cards to 32 GB. (Note: Models with card slots and firmware R8.4 through R9.3e support microSD cards up to 2 GB only.)
Backup battery	Rechargeable (recharges whenever the brain has power), 3-year power-off data retention (replacement part number: SNAP-PAC-BATTERY-ML2430) ¹
Communication	
Ethernet	Two independent 10/100 Mbps Ethernet network interfaces (RJ-45 connectors). Each interface has a separate IP address. Connects to host and I/O. Supports Auto MDI-X (crossover cable not needed)
RS-232 serial	One RS-232 serial port ² with hardware handshaking. Connects to host (via modem and PPP) or serial device. Cannot connect to serial I/O.
I/O unit compatibility	SNAP PAC I/O units: SNAP PAC R-series and EB-series I/O units <i>groov</i> RIO edge I/O units <i>groov</i> EPIC I/O units
Power requirements	5.0–5.2 VDC @ 1.5 A
Hold-down screw	Torque: Not to exceed 1 in-lb (0.11 N-m)
Connector screw	Torque: 1.7 in-lb (0.19 N-m)
Environmental	
Operating temperature	-20 °C to 60 °C
Storage temperature	-40 °C to 85 °C
Humidity	0% to 95% relative humidity, non-condensing
Software	
PAC Project Basic	Includes programming, HMI software, and configuration software; included with purchase of controller.
PAC Project Professional	PAC Project Basic plus OPC 2.0-compliant OPC server, database connectivity, OptoControl strategy and OptoDisplay project importing, and support for Ethernet link redundancy or network segmenting.
RESTful API ³	Use HTTPS to access data (read/write or read-only) from controller tags using your chosen programming language. Data returned in JSON. More information at developer.opto22.com
Number of charts that can run simultaneously	16
Agency approvals and certifications	All models: DFARS, CE, RoHS; UKCA All models except -FM models: UL (-FM and -B models only) Factory Mutual approved, ATEX
Warranty	30 months from date of manufacture

- Other features
- Multiple protocol support including TCP/IP, HTTP/HTTPS, FTP, EtherNet/IP, Modbus/TCP, SNMP v2.0c, OptoMMP™, and SMTP
 - Built-in I/O processor handles up to 16 digital⁴, analog, and serial I/O modules on the same rack
 - Real-time clock
 - FTP server/client with file system (in RAM and in removable storage)
 - Scratch Pad area for peer-to-peer communication
 - Configurable link redundancy or segmented networking for I/O-controller subnetting (when using PAC Project Professional)

¹ Models manufactured before July 1, 2007 have a user-replaceable 3-volt CR2032 Lithium battery (typical service life with power off: 5 years).

² Connecting to a serial device requires configuration in PAC Manager; PAC Control handles communication.

³ Requires firmware R9.5a or higher.

⁴ SNAP-PAC-R1s with serial numbers lower than 600,000, and all SNAP-PAC-R1-Bs, are limited to eight 4-channel digital modules per rack; remaining eight can be analog, serial, and high-density digital modules.

SYSTEM ARCHITECTURE

For the network shown in this diagram, either PAC Project Professional or PAC Project Basic can be used.

SNAP PAC R-series Controller in Basic Network Configuration

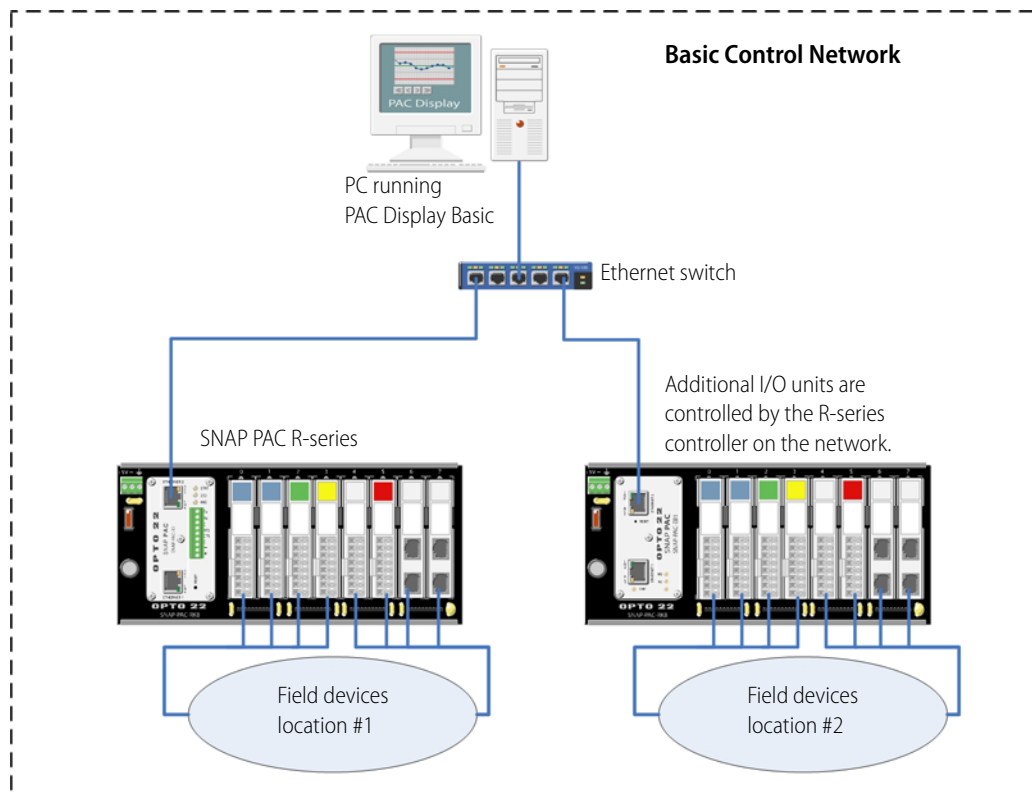

In this diagram, the SNAP PAC R-series controller uses one network interface to communicate with host computers and control I/O. The controller controls I/O on its own rack and on other Ethernet-based I/O units.

SYSTEM ARCHITECTURE (CONTINUED)

The network shown in this diagram requires PAC Control Professional, PAC Display Professional, and OptoDataLink.

SNAP PAC R-series Controller Isolating Ethernet Networks into Zones

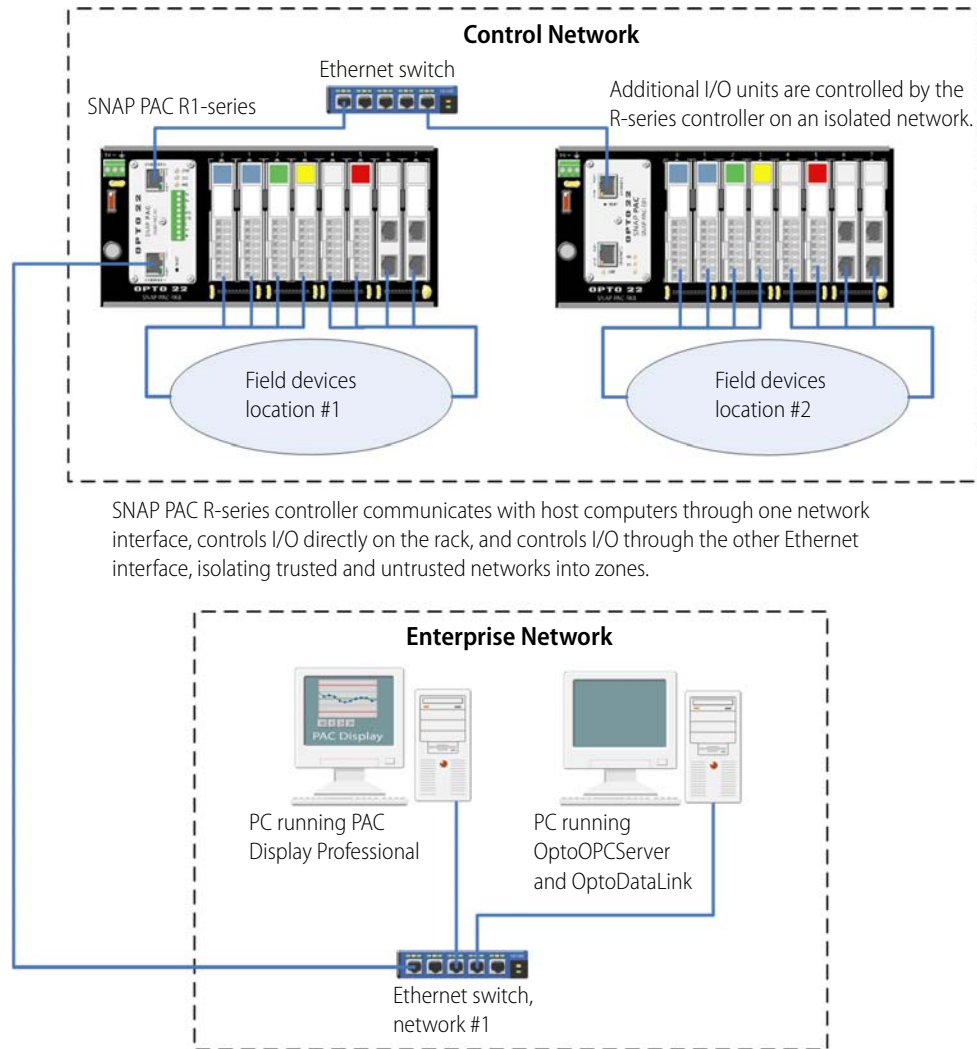

This diagram shows two SNAP PAC I/O units connected together over an Ethernet network and controlled by a SNAP PAC R-series controller running a PAC Control strategy.

The controller is also connected to a larger, separate enterprise Ethernet network to provide data to PCs running

Opto 22's PAC Display HMI software, OptoOPCServer, and OptoDataLink.

Sitting between the two networks, the SNAP PAC R-series controller isolates I/O and control traffic on the trusted network from the untrusted enterprise network, and vice versa.

SYSTEM ARCHITECTURE (CONTINUED)

SNAP PAC R-series Controller in Redundant Network Configuration

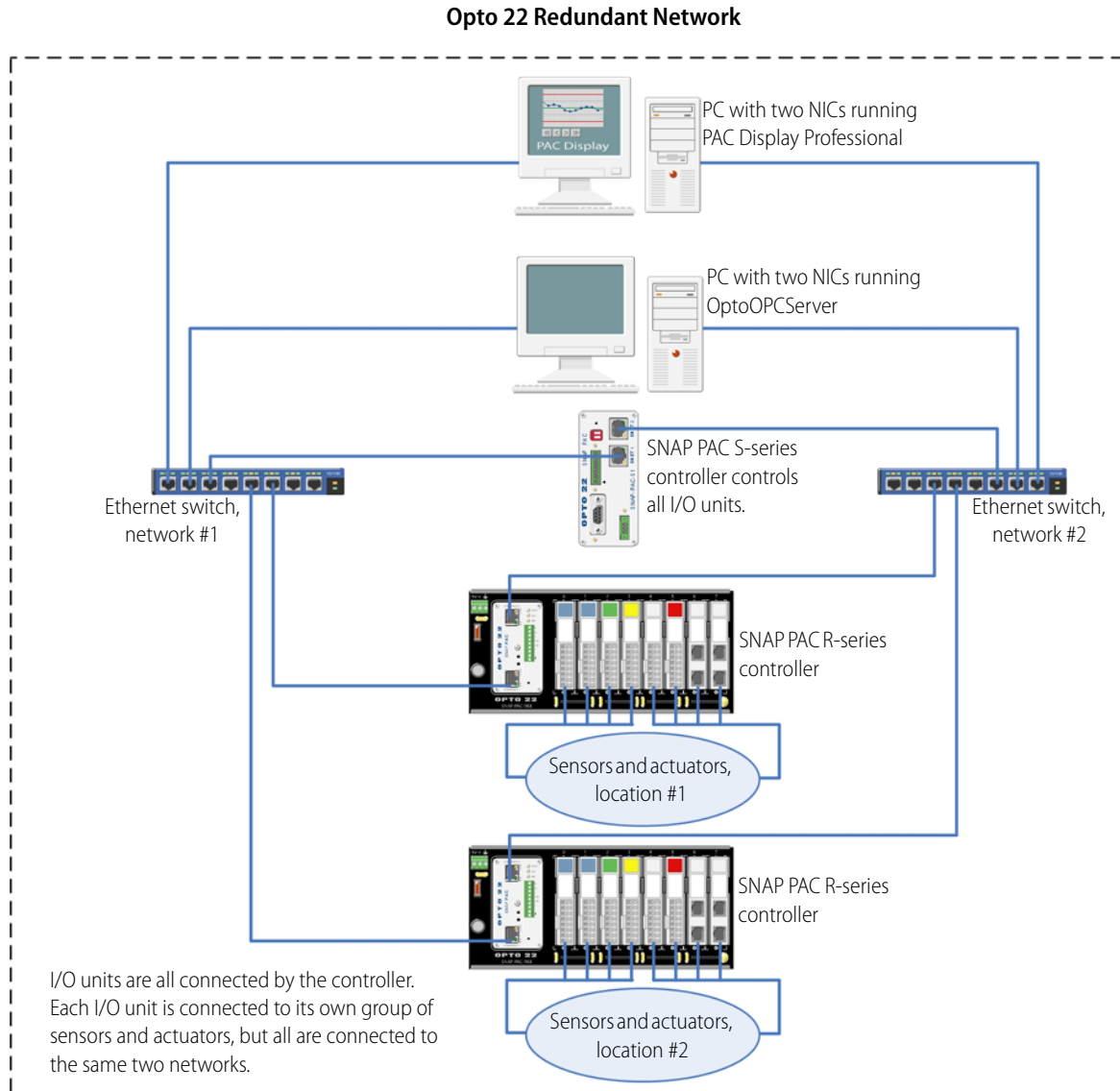

This diagram shows two SNAP PAC R-Series controllers functioning as I/O unit brains connected to two separate Ethernet networks.

This configuration addresses the concern that an Ethernet network may fail or need maintenance, leaving the PC running OptoOPCServer and OptoDataLink, the PC running

PAC Display, the controller, and the I/O units unable to communicate.

In this configuration, if one network goes down, devices can still communicate because the SNAP PAC R-series controllers and the SNAP PAC S-series controllers both have two network interfaces, and each PC in this system has two network interface cards.

SNAP PAC R-SERIES COMPARISON CHART

The following table compares SNAP PAC R-series controllers with firmware 9.4 or newer.

FEATURE		SNAP-PAC-R1	SNAP-PAC-R1-FM	SNAP-PAC-R2	SNAP-PAC-R2-FM	SNAP-PAC-R1-B
Factory Mutual approval			●		●	●
UL approval		●	●	●	●	●
Digital I/O point features	Input latching	●	●	●	●	●
	On/off status	●	●	●	●	●
	Watchdog timer	●	●	●	●	●
	High-speed counting (up to 20 kHz) ¹	●	●			●
	Quadrature counting ²	●	●			●
	On-pulse and off-pulse measurement ^{1,3}	●	●			●
	Frequency and Period measurement ^{1,3}	●	●			●
	TPO (time-proportional output) ³	●	●	●	●	●
	Digital totalizing ^{1,3}	●	●	●	●	●
	Pulse generation (N pulses, continuous square wave, on-pulse, and off-pulse) ³	●	●	●	●	●
Analog I/O point features	Thermocouple linearization (32-bit floating point for linearized values)	●	●	●	●	●
	Minimum/maximum values	●	●	●	●	●
	Offset and gain	●	●	●	●	●
	Scaling	●	●	●	●	●
	TPO (time-proportional output) ⁴	●	●	●	●	●
	Output clamping	●	●	●	●	●
	Filter weight	●	●	●	●	●
	Watchdog timer	●	●	●	●	●
	Analog totalizing ³	●	●	●	●	●
Ramping ³	●	●	●	●	●	
High-density digital (HDD) modules (inputs and outputs)		●	●	●	●	●
Serial communication modules		●	●	●	●	●
PID logic (maximum 96 PID loops per controller)		●	●	●	●	●
Works with PAC Project software		●	●	●	●	●
Runs PAC Control strategies		●	●	●	●	●
Ethernet network (two independent network interfaces)		●	●	●	●	●
Security for Ethernet network (IP filtering, port access)		●	●	●	●	●
OPC driver support		●	●	●	●	●

FEATURE	SNAP-PAC-R1	SNAP-PAC-R1-FM	SNAP-PAC-R2	SNAP-PAC-R2-FM	SNAP-PAC-R1-B
Modbus/TCP (slave)	●	●	●	●	●
EtherNet/IP for communication with Allen-Bradley RSLogix PLCs	●	●	●	●	●
REST API (requires firmware R9.5a or higher)	●	●	●	●	●
HTTP/HTTPS (requires firmware R9.5a or higher)	●	●	●	●	●
OptoMMP memory-mapped protocol	●	●	●	●	●
SNMP (network management of I/O & variables)	●	●	●	●	●
PPP (dial-up and radio modems)	●	●	●	●	●
FTP server and client	●	●	●	●	●
Email (SMTP client)	●	●	●	●	●
UDP Streaming of I/O data to host	●	●	●	●	●
Serial port (RS-232)	●	●	●	●	●
Scratch Pad area—bits, floats, integers, strings	●	●	●	●	●
Digital events, alarm events, serial events	●	●	●	●	●
Event messages	●	●	●	●	●
Data logging in the controller	●	●	●	●	●
I/O point data mirroring and memory map copying	●	●	●	●	●
Realtime clock (RTC)	●	●	●	●	●
Mounting rack	SNAP PAC racks			B-series	
Number of modules per mounting rack	4, 8, 12, or 16			4, 8, 12, 16	
Module types and maximum numbers allowed per I/O unit (with largest rack)	16 digital (any type) 16 analog 8 serial			8 4-ch digital, 8 serial, 16 analog or HDD	

1 4-channel digital modules only; not available on high-density digital modules

2 Requires a SNAP quadrature input module (SNAP-IDC5Q)

3 Requires PAC Control Professional 8.2 or newer, or PAC Control Basic 9.0 or newer

4 Requires a SNAP analog TPO module (SNAP-AOD-29)

CONNECTORS AND INDICATORS

The following information applies to all SNAP PAC R-series controllers.

NOTE: The microSD card slot is included in R-series PACs manufactured in November 2008 and later. PACs manufactured before November 2008 do not have this feature

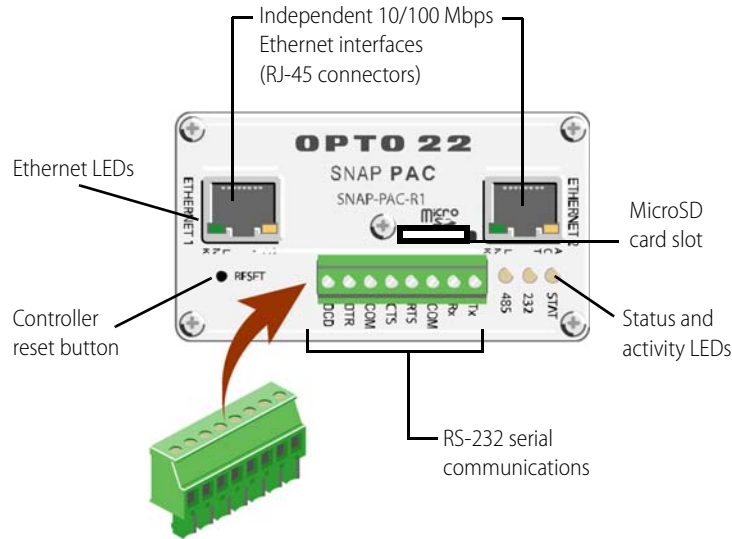

RS-232 Port (Port 0)

Pin	Description
1	TX
2	RX
3	COM
4	RTS
5	CTS
6	COM
7	DTR
8	DCD

Status and Activity LEDs

Indicator	Description
ACT	Ethernet network activity
LNK	Link established with Ethernet network
STAT	Startup status, control program operational status, MicroSD card access
232	RS-232 serial activity
PPP	PPP status

RS-232 Serial Cable Wiring*

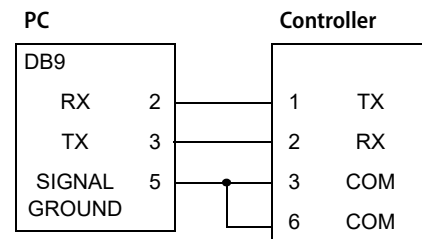

* Minimum requirements for wiring an RS-232 serial cable to connect to a PC. If you want to connect the controller to a modem, see form #1595, the *SNAP PAC R-Series Controllers User's Guide*, for all eight pin connections.

DIMENSIONS

This diagram applies to all R-series PACs.

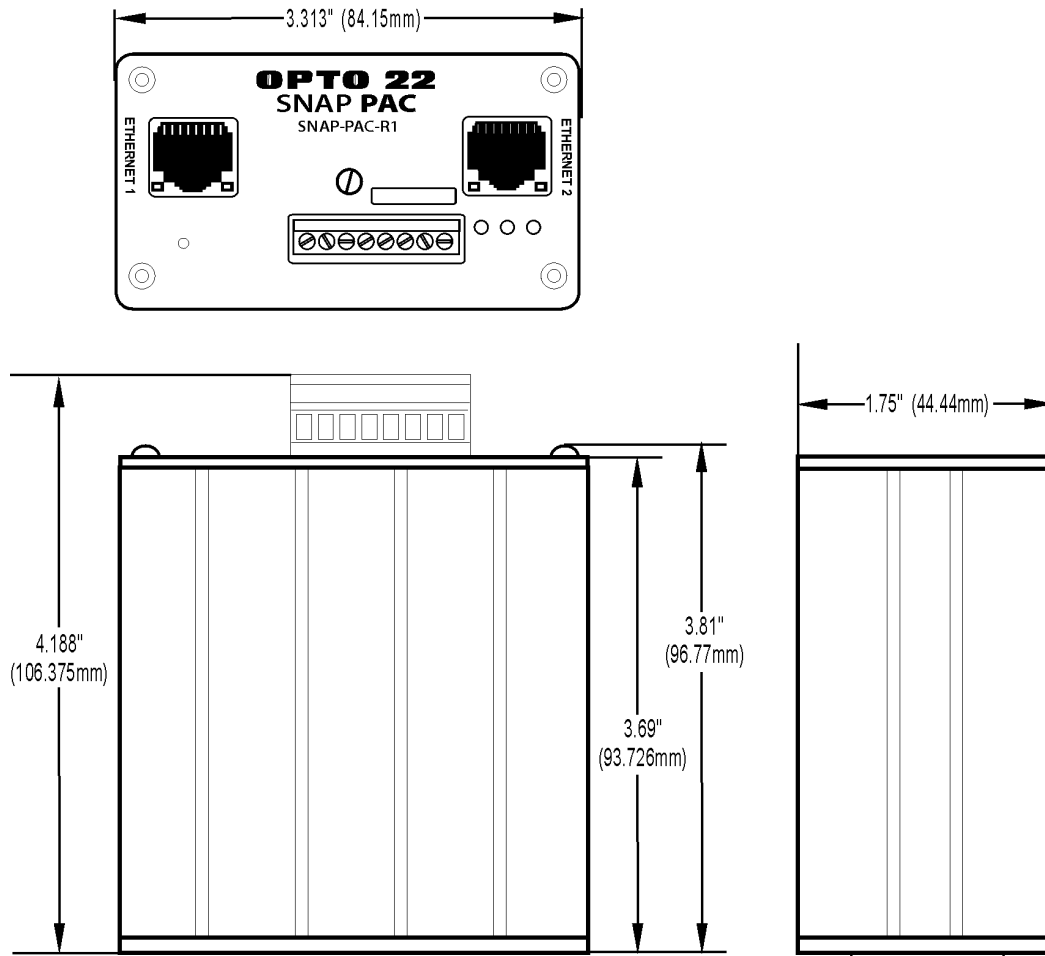

PRODUCTS

Opto 22 develops and manufactures reliable, easy-to-use, open standards-based hardware and software products. Industrial automation, process control, remote monitoring, data acquisition, and industrial internet of things (IIoT) applications worldwide all rely on Opto 22.

groov RIO®

groov RIO edge I/O offers a single, compact, PoE-powered industrial package with web-based configuration and IIoT software built in, support for multiple OT and IT protocols, and security features like a device firewall, data encryption, and user account control.

Standing alone, groov RIO connects to sensors, equipment, and legacy systems, collecting and securely publishing data from field to cloud. Choose a universal I/O model with thousands of possible field I/O configurations, with or without Ignition from Inductive Automation®, or a RIO EMU energy monitoring unit that reports 64 energy data values from 3-phase loads up to 600 VAC, Delta or Wye.

You can also use groov RIO with a Modbus/TCP master or as remote I/O for a groov EPIC system.

groov EPIC® System

Opto 22's groov Edge Programmable Industrial Controller (EPIC) system gives you industrially hardened control with a flexible Linux®-based processor with gateway functions, guaranteed-for-life I/O, and software for your automation and IIoT applications.

groov EPIC Processor

The heart of the system is the groov EPIC processor. It handles a wide range of digital, analog, and serial functions for data collection, remote monitoring, process control, and discrete and hybrid manufacturing.

In addition, the EPIC provides secure data communications among physical assets, control systems, software applications, and online services, both on premises and in the cloud. No industrial PC needed.

Configuring and troubleshooting I/O and networking is easier with the EPIC's integrated high-resolution color touchscreen. Authorized users can manage the system locally on the touchscreen, on a monitor connected via the HDMI or USB ports, or on a PC or mobile device with a web browser.

groov EPIC I/O

groov I/O connects locally to sensors and equipment. Modules have a spring-clamp terminal strip, integrated wireway, swing-away cover, and LEDs indicating module health and discrete channel status. groov I/O is hot swappable, UL Hazardous Locations approved, and ATEX compliant.

groov EPIC Software

The groov EPIC processor comes ready to run the software you need:

- Programming: Choose flowchart-based PAC Control, CODESYS Development System for IEC61131-3 compliant programs, or secure shell access (SSH) to the Linux OS for custom applications
- Node-RED for creating simple IIoT logic flows from pre-built nodes
- Efficient MQTT data communications with string or Sparkplug data formats
- Multiple OPC UA server options
- HMI: groov View to build your own HMI viewable on touchscreen, PCs, and mobile devices; PAC Display for a

Windows HMI; Node-RED dashboard UI

- Ignition or Ignition Edge® from Inductive Automation (requires license purchase) with OPC-UA drivers to Allen-Bradley®, Siemens®, and other control systems, and MQTT communications

Older products

From solid state relays, to world-famous G4 and SNAP I/O, to SNAP PAC controllers, older Opto 22 products are still supported and working hard at thousands of installations worldwide. You can count on us for the reliability and service you expect, now and in the future.

QUALITY

Founded in 1974, Opto 22 has established a worldwide reputation for high-quality products. All are made in the U.S.A. at our manufacturing facility in Temecula, California.

Because we test each product twice before it leaves our factory rather than testing a sample of each batch, we can afford to guarantee most solid-state relays and optically isolated I/O modules for life.

FREE PRODUCT SUPPORT

Opto 22's California-based Product Support Group offers free technical support for Opto 22 products from engineers with decades of training and experience. Support is available in English and Spanish by phone or email, Monday–Friday, 7 a.m. to 5 p.m. PST.

Support is always available on our website, including [free online training](#) at OptoU, how-to [videos](#), [user's guides](#), the Opto 22 KnowledgeBase, and [OptoForums](#).

PURCHASING OPTO 22 PRODUCTS

Opto 22 products are sold directly and through a worldwide network of distributors, partners, and system integrators. For more information, contact Opto 22 headquarters at **800-321-6786** (toll-free in the U.S. and Canada) or **+1-951-695-3000**, or visit our website at www.opto22.com.

