

# **SNAP PAC R-SERIES CONTROLLER USER'S GUIDE**

**SNAP-PAC-R1**

**SNAP-PAC-R1-B**

**SNAP-PAC-R1-FM**

**SNAP-PAC-R2**

**SNAP-PAC-R2-FM**



# SNAP PAC R-SERIES CONTROLLER USER'S GUIDE

SNAP-PAC-R1  
SNAP-PAC-R1-B  
SNAP-PAC-R1-FM  
SNAP-PAC-R2  
SNAP-PAC-R2-FM

Form 1595-211007–October 2021

**OPTO 22**  
Your Edge in Automation.™

43044 Business Park Drive • Temecula • CA 92590-3614  
Phone: 800-321-OPTO (6786) or 951-695-3000  
Fax: 800-832-OPTO (6786) or 951-695-2712  
[www.opto22.com](http://www.opto22.com)

Product Support Services  
800-TEK-OPTO (835-6786) or 951-695-3080  
Fax: 951-695-3017  
Email: [support@opto22.com](mailto:support@opto22.com)  
Web: [support.opto22.com](http://support.opto22.com)

SNAP PAC R-Series Controller User's Guide  
Form 1595-211007—October 2021

Copyright © 2006–2021 Opto 22.  
All rights reserved.

Printed in the United States of America.

The information in this manual has been checked carefully and is believed to be accurate; however, Opto 22 assumes no responsibility for possible inaccuracies or omissions. Specifications are subject to change without notice.

Opto 22 warrants all of its products to be free from defects in material or workmanship for 30 months from the manufacturing date code. This warranty is limited to the original cost of the unit only and does not cover installation, labor, or any other contingent costs. Opto 22 I/O modules and solid-state relays with date codes of 1/96 or newer are guaranteed for life. This lifetime warranty excludes reed relay modules, *groov* and SNAP serial communication modules, SNAP PID modules, and modules that contain mechanical contacts or switches. Opto 22 does not warrant any product, components, or parts not manufactured by Opto 22; for these items, the warranty from the original manufacturer applies. Refer to Opto 22 form 1042 for complete warranty information.

---

Wired+Wireless controllers and brains are licensed under one or more of the following patents: U.S. Patent No(s). 5282222, RE37802, 6963617; Canadian Patent No. 2064975; European Patent No. 1142245; French Patent No. 1142245; British Patent No. 1142245; Japanese Patent No. 2002535925A; German Patent No. 60011224.

Opto 22 FactoryFloor, *groov*, *groov* EPIC, *groov* RIO, mobile made simple, The Edge of Automation, Optomux, and Pamux are registered trademarks of Opto 22. Generation 4, *groov* Server, ioControl, ioDisplay, ioManager, ioProject, ioUtilities, *mistic*, Nvio, Nvio.net Web Portal, OptoConnect, OptoControl, OptoDataLink, OptoDisplay, OptoEMU, OptoEMU Sensor, OptoEMU Server, OptoOPCServer, OptoScript, OptoServer, OptoTerminal, OptoUtilities, PAC Control, PAC Display, PAC Manager, PAC Project, PAC Project Basic, PAC Project Professional, SNAP Ethernet I/O, SNAP I/O, SNAP OEM I/O, SNAP PAC System, SNAP Simple I/O, SNAP Ultimate I/O, and Wired+Wireless are trademarks of Opto 22.

ActiveX, JScript, Microsoft, MS-DOS, VBScript, Visual Basic, Visual C++, Windows, and Windows Vista are either registered trademarks or trademarks of Microsoft Corporation in the United States and other countries. Linux is a registered trademark of Linus Torvalds. ARCNET is a registered trademark of Datapoint Corporation. Modbus is a registered trademark of Schneider Electric, licensed to the Modbus Organization, Inc. Wiegand is a registered trademark of Sensor Engineering Corporation. Allen-Bradley, CompactLogix, ControlLogix, MicroLogix, SLC, and RSLogix are either registered trademarks or trademarks of Rockwell Automation. CIP and EtherNet/IP are trademarks of ODVA. Raspberry Pi is a trademark of the Raspberry Pi Foundation. The registered trademark Ignition by Inductive Automation® is owned by Inductive Automation and is registered in the United States and may be pending or registered in other countries. CODESYS® is a registered trademark of 3S-Smart Software Solutions GmbH.

*groov* includes software developed by the OpenSSL Project for use in the OpenSSL Toolkit. (<http://www.openssl.org>)

All other brand or product names are trademarks or registered trademarks of their respective companies or organizations.

Opto 22  
Your Edge in Automation.

# Table of Contents

<b>Chapter 1: Overview</b> .....	<b>1</b>
Introduction .....	1
Ethernet Communication .....	2
Serial Communication .....	2
I/O Mounting Racks .....	2
Ethernet PAC for Legacy I/O Racks .....	2
SNAP I/O .....	2
Forward Compatibility .....	3
PAC Project Software .....	3
For Developers: SNAP PAC REST API .....	4
About this Guide .....	4
Related Documentation .....	5
For Help .....	5
<b>Chapter 2: Installation</b> .....	<b>7</b>
What You Will Need .....	7
Installing Hardware .....	7
Installing Modules on the Rack .....	7
Removing a Module .....	9
Installing the Controller .....	9
What's Next? .....	10
Configuring I/O .....	10
Using PPP Over a Modem .....	11
Configuring PPP on the Controller .....	12
Attaching the Modem to a SNAP PAC R-Series Controller .....	12
<b>Chapter 3: System Information</b> .....	<b>13</b>
Communication Options .....	13
Simultaneous Communication .....	14
Accessing SNAP R-Series Controllers over the internet .....	14
Choosing Communication Methods .....	15
System Architecture .....	16
Understanding the SNAP PAC R-series Controller .....	16
The I/O Side of the Controller .....	16
The Control Side of the Controller .....	17

Controlling the System .....	17
Using Data for Peer-to-Peer Communication .....	18
Communicating with Enterprise Systems and Third-Party Software .....	19
The Complete System .....	20
Networking.....	22
Connecting the Controller Directly to a PC or Master Controller .....	22
Attaching the Controller to an Existing Ethernet Network .....	22
Isolating the Control Network in a Separate Zone .....	22
Using the Controller in an Independent Network .....	23
Communicating with the System via Modem .....	23
Network Architecture Diagrams .....	23
Basic Control Network .....	24
Network Zoning: Ethernet Connections to Host and I/O Units .....	25
Ethernet Link Redundancy .....	26
Specifications, Connectors, and Dimensions.....	27
Connectors and LEDs .....	28
Dimensions .....	29
Information on Features.....	30
Digital Point Features .....	30
Analog Point Features .....	31
Serial Communication .....	31
PID Loops .....	32
Additional Features .....	32
SNAP-PAC-R1 and -R2 Comparison Chart .....	33

## **Chapter 4: Maintenance and Troubleshooting .....35**

Maintaining the SNAP PAC R-Series Controller.....	35
Backup Battery .....	35
Changing the Controller's IP Address .....	35
Loading New Firmware .....	36
Setting Time and Date .....	36
Resetting the Controller .....	36
Using the MicroSD Card .....	37
Card Type and Format .....	37
MicroSD/SDHC Card Uses .....	37
Storing and Accessing Data or Files .....	39
Displaying Free Space on the Card .....	40
Checking Firmware and Loader Versions .....	40
Replacing a Controller .....	41
Updating Firmware .....	44
Bootting from Firmware on the Card .....	45
Updating, Running, or Testing a Strategy .....	47
Disabling or Enabling Firmware and Strategy Updates Via the Card .....	49
Blink Codes .....	49
STAT LED .....	49
PPP LED .....	50
232 LED .....	51

Troubleshooting the SNAP PAC R-Series Controller .....	51
Getting Device and Firmware Information .....	51
Communicating with the Controller .....	52
Pinging the Controller .....	52
Accessing the Controller with PAC Manager .....	52
Solving Network Problems .....	53
Additional Troubleshooting Tools .....	55
Making Sure the Controller is in Normal Mode .....	55
TCP Settings .....	55
Troubleshooting I/O Modules: Frequently Asked Questions .....	56
SNAP Digital Troubleshooting .....	56
SNAP Analog Troubleshooting .....	58
<b>Appendix A: SNAP Mounting Racks and Power Supplies .....</b>	<b>59</b>
Introduction .....	59
SNAP Mounting Racks.....	59
SNAP Power Supplies .....	60
Primary Power Supply .....	60
Determining Power Requirements .....	61
Wiring the Primary Power Supply .....	62
Loop Power Supply .....	62
<b>Index .....</b>	<b>65</b>





# 1: Overview

## INTRODUCTION

The affordable and compact SNAP PAC R-series programmable automation controllers provide powerful, real-time control and communication to meet your industrial control, monitoring, and data acquisition and exchange needs. Part of the Opto 22 SNAP PAC System™, the R-series PAC is a rack-mounted, industrially hardened unit that can handle multiple tasks involving digital and analog control, serial string handling, communication, and enterprise connectivity.

Used with the included PAC Project Basic software suite (or PAC Project Professional, purchased separately), the Ethernet-based SNAP PAC R-series controller runs control programs written in Opto 22's PAC Control™ software. It can monitor and control a wide range of devices and equipment wired to the I/O on its own rack and to I/O on distributed racks equipped with SNAP PAC EB-series brains or *groov* RIO® edge I/O modules. Alternatively, the R-series controller can be used as a slave to a larger controller, either a *groov* EPIC® edge programmable industrial controller, a SNAP PAC S-series standalone industrial controller, or a SoftPAC™ software-based controller for PC-based control.

SNAP PAC R-series controllers are well suited to process control, discrete manufacturing, and hybrid industries and applications.

Several models are available:

- **SNAP-PAC-R1**, **SNAP-PAC-R1-FM**, and **SNAP-PAC-R1-B** each control a mix of SNAP analog, digital (both 4-channel and high-density), and serial modules. Full digital functions include high-speed counting; quadrature counting; and pulse, period, and frequency measurement. The -FM model is Factory Mutual approved. The -B model is designed to mount on SNAP B-series racks so that older I/O units can be easily upgraded to a newer controller.
- **SNAP-PAC-R2** and **SNAP-PAC-R2-FM** also control a mix of SNAP analog, 4-channel and high-density digital, and serial modules. High-speed digital functions are not included. The -FM model is Factory Mutual approved.

Built-in functions and comparisons of the SNAP-PAC-R1 and SNAP-PAC-R2 are shown in the table on [page 33](#).



**SNAP-PAC-R1 controller**

## Ethernet Communication

All SNAP PAC R-series controllers communicate over standard 10/100 Mbps Ethernet networks and can be attached to an existing network. The controllers can also be used in an independent control network built with standard, off-the-shelf Ethernet hardware.

SNAP PAC R-series controllers include two 10/100 Mbps Ethernet interfaces for networking to Ethernet hosts and to other I/O units. These interfaces support Auto MDI-X, which means you can use a standard straight-through Ethernet cable; a crossover cable is not needed for direct connection to a PC. The two independent Ethernet ports have separate IP addresses that can be used with PAC Project™ Professional software to set up redundant network links to safeguard the availability and reliability of an I/O system, or to segment a control system's network from the enterprise LAN.

Supported protocols over Ethernet include EtherNet™ /IP, Modbus® /TCP, SMTP, SNMP, FTP, and OptoMMP.

## Serial Communication

SNAP PAC R-series controllers provide an RS-232 serial link to support Point-to-Point Protocol (PPP) modem connections—for creating TCP/IP networks over serial or PSTN (Public Switched Telephone Network) lines—as well as remote serial device communication.

The RS-232 serial interface supports either a modem connection using PPP or general-purpose communication with serial devices, allowing you to send and receive data from a serial device connected directly to the controller. For additional serial interfaces, you can add one or more SNAP serial communication modules on the rack.

*NOTE: The R-series controller does not include an RS-485 port and cannot be used to control Opto 22 serial I/O processors, such as the SNAP PAC SB-series brains. Use an S-series controller for serial brains.*

## I/O Mounting Racks

SNAP PAC R-series controllers must be connected to the appropriate rack to avoid damage to the controller. Both the SNAP-PAC-R1 and R2 are designed to work with SNAP PAC mounting racks, which are available with 4, 8, 12, or 16 positions for Opto 22 SNAP I/O modules. Part numbers are SNAP-PAC-RCK4, SNAP-PAC-RCK8, SNAP-PAC-RCK12, and SNAP-PAC-RCK16. Factory Mutual-approved versions of these racks, with part numbers ending in -FM, are also available.

### Ethernet PAC for Legacy I/O Racks

The SNAP-PAC-R1-B is a PAC-R1 for use with older SNAP B-series racks (only B-series racks with a B in the part number; not the SNAP-D64RS rack). This PAC provides an upgrade path from legacy brains and rack-mounted controllers such as the SNAP-B3000-ENET or SNAP-UP1-ADS that use B-series racks. See the [SNAP I/O Racks](#) data sheet (form 0784) for more information on racks.

The SNAP-PAC-R1-B uses the same firmware and has the same functionality as the SNAP-PAC-R1, except that 4-channel digital modules can be placed only in slots 0-7 due to limitations of the rack.

## SNAP I/O

The SNAP PAC R-series controllers support all SNAP I/O modules available on our website. SNAP digital I/O modules contain four input or output points, and SNAP high-density digital modules contain 16 or 32 input or output points. SNAP analog modules contain 2 to 32 points, depending on the module.

## Forward Compatibility

SNAP PAC R-series controllers are compatible with newer *groov EPIC* processors and *groov RIO* edge I/O units, which add industrial internet of things (IIoT) data communications and cybersecurity features to your system. Both *groov EPIC* and *groov RIO* can be used as I/O units with an R-series controller. If you already have R-series controllers, you can use them as I/O units with a *groov EPIC* system.

Depending on your application, consider purchasing a *groov RIO* edge I/O module or a *groov EPIC* processor instead of a SNAP PAC R-series controller.

- If you don't need traditional control, *groov RIO* offers significant security features, thousands of I/O options, built-in IIoT software, and lower cost, in a small footprint suited for hazardous industrial areas.
- For control, *groov EPIC* provides system security, better performance, control programming options, built-in IIoT software, and much more.

For more information, see [groov RIO](#) and the [groov EPIC system](#) on our website, or contact our pre-sales engineers.

## PAC Project Software

SNAP PAC controllers use Opto 22's **PAC Project** Microsoft® Windows®-compatible automation software for programming, human-machine-interface (HMI) development, and OPC connectivity.

Two versions of PAC Project are available on our website, [www.opto22.com](http://www.opto22.com): PAC Project Basic is free to download; PAC Project Professional is available for purchase and download.

- **PAC Project Basic** includes PAC Control™ for developing control programs, PAC Display™ for creating operator interfaces, and PAC Manager™ configuration software.
- **PAC Project Professional** adds expanded versions of PAC Control and PAC Display plus a SoftPAC software-based controller for PC-based control, OptoOPCServer™ software for exchanging data with OPC 2.0-compliant client software applications, and OptoDataLink™ for exchanging SNAP PAC System data with databases (including Microsoft SQL Server, Microsoft Access, and MySQL), text files, and email systems).

You can also purchase PAC Control Professional, PAC Display Professional, SoftPAC, OptoOPCServer, and OptoDataLink separately. For details, see the [PAC Project Data Sheet](#) (form 1699).

**PAC Control Basic** is a graphical, flowchart-based programming tool for machine control and process applications. Using PAC Control, you create, download, and run strategies on a SNAP PAC or *groov EPIC* controller. In addition to flowchart programming with subroutine capability, PAC Control includes a powerful, built-in scripting language based on C and other procedural languages.

**PAC Control Professional** adds the ability to import legacy OptoControl strategies, support for older *mistic*™ serial I/O units, and support for the dual independent Ethernet ports on a SNAP PAC controller.

The number of PAC Control flowcharts that can simultaneously run depends on the controller, but the PAC Control strategy can contain a much larger number of flowcharts. The total number of flowcharts is limited only by the memory available for strategy storage.

**PAC Display Basic** is an intuitive HMI package for building operator interfaces, or *projects*, for communicating with a SNAP PAC controller. PAC Display offers a full-featured HMI including alarming, trending, and a built-in library of 3,000 industrial automation graphics.

**PAC Display Professional** adds the ability to import projects created in OptoDisplay, part of the legacy Opto 22 FactoryFloor® software suite, and using redundant Ethernet communication links on SNAP PAC controllers. PAC Display Professional can also connect to Ethernet-based FactoryFloor controllers running OptoControl strategies.

**SoftPAC** is a software-based programmable automation controller (PAC) designed for PC-based control. Programmed just like an Opto 22 hardware controller, SoftPAC runs your PAC Control strategy independently

on an embedded or standalone PC. SoftPAC takes advantage of a PC's speed and file capabilities for applications requiring extended file storage, frequent access to files, or math-intensive processes.

**OptoOPCServer** is a fast, efficient OPC 2.0-compliant server for communicating with many Opto 22 products, including SNAP PAC controllers and I/O units, plus legacy Opto 22 Ethernet-based controllers and I/O. Using OptoOPCServer, you can consolidate data from all these Opto 22 systems into the OPC client software of your choice, such as third-party HMI and data acquisition packages, and custom software applications you create with tools such as Visual C++ .

**OptoDataLink** is a software application that makes it easy to share data from the SNAP PAC System with commonly used databases, including Microsoft SQL Server, Microsoft Access, and MySQL, as well as text files. The I/O points and strategy variables already created in your PAC Control strategy are automatically available for OptoDataLink to use for data exchange.

**PAC Manager** is a utility application for assigning IP addresses to SNAP PAC controllers and brains, reading or changing basic controller configuration, and configuring and testing I/O.

### For Developers: SNAP PAC REST API

If you're a developer who'd like to use PAC Control strategy tags in communications with other devices, the Opto 22 SNAP PAC REST API is a secure and powerful way to do just that. The API is available in SNAP PAC R-series and S-series controllers with PAC firmware R9.5a and higher. To configure https access to your PAC's RESTful server and learn how to call the API, visit [developer.opto22.com](http://developer.opto22.com).

## ABOUT THIS GUIDE

This guide shows you how to install and use SNAP PAC R-series controllers. This guide assumes that you have some familiarity with TCP/IP and Ethernet networking. If you are not familiar with these subjects, we strongly suggest you consult commercially available resources to learn about them before attempting to install or use SNAP PAC R-series controllers.

If you are using Modbus/TCP for communicating with SNAP PAC R-series controllers, this guide assumes that you are already familiar with Modbus/TCP. See the [Modbus/TCP Protocol Guide](#) (form 1678) for additional information.

If you are using EtherNet/IP for communication, you should already be familiar with EtherNet/IP. See the [EtherNet/IP for SNAP PAC Protocol Guide](#) (form 1770).

The following sections are included in this user's guide:

**Chapter 1: Overview**—information about the guide and how to reach Opto 22 Product Support.

**Chapter 2: Installation**—quick-start steps to get SNAP PAC R-series controllers up and running quickly.

**Chapter 3: System Information**—conceptual information on networking and communicating with SNAP PAC R-series controllers; descriptions of features, capabilities, and specifications for SNAP PAC R-series controllers.

**Chapter 4: Maintenance and Troubleshooting**—assigning and changing IP addresses, resetting the controller to factory defaults, using the microSD slot, upgrading firmware, and tips for resolving difficulties you may encounter while working with SNAP PAC R-series controllers.

**Appendix A: SNAP Mounting Racks and Power Supplies**—wiring diagram examples for assembling your SNAP PAC R-series controller, SNAP PAC rack, and power supply.

## RELATED DOCUMENTATION

You'll find most of the documentation to build and maintain your control system in the PAC Project folder that's added to your Windows Desktop when you install PAC Project. While using PAC Project applications, you can get online help by clicking Help in the menu bar or the Help buttons in dialog boxes, or simply by pressing the F1 key.

Here's a brief list of documents you may find helpful. You can also download other documents, sample files, software utilities, technical notes, integration kits, and much more from the [Opto 22 website](#).

*TIP: To easily find documents on our website, search on the form number.*

For this information	See this guide	Form #
Assigning IP addresses, loading new firmware, configuring SNAP I/O points and system functions	<a href="#">PAC Manager User's Guide</a> <sup>1</sup>	1704
Designing flowchart-based control programs for the system	<a href="#">PAC Control User's Guide</a> <sup>1</sup>	1700
	<a href="#">PAC Control Command Reference</a> <sup>1</sup>	1701
	<a href="#">PAC Control Commands Quick Reference</a>	1703
Securely accessing data in the PAC via its REST API	<a href="#">developer.opto22.com</a>	–
Programming your own applications by using either: <ul style="list-style-type: none"> <li>The OptoMMP protocol for memory-mapped controllers and brains</li> <li>One of the <a href="#">OptoMMP Software Development Kits (SDKs)</a></li> </ul>	<a href="#">OptoMMP Protocol Guide</a>	1465
Using redundant controllers	<a href="#">SNAP PAC System Redundancy User's Guide</a>	1831
Installing and using SNAP PAC S-series controllers	<a href="#">SNAP PAC S-series Controller User's Guide</a>	1592
Installing and using SNAP PAC R-series controllers	<a href="#">SNAP PAC R-series Controller User's Guide</a>	1595
Installing and using SNAP PAC EB- and SB-series brains	<a href="#">SNAP PAC Brains User's Guide</a>	1690
Communicating with I/O units using OPC	<a href="#">OptoOPCServer User's Guide</a>	1439
Communicating with I/O units using Modbus/TCP	<a href="#">Modbus/TCP Protocol Guide</a>	1678
Communicating with I/O units using EtherNet/IP	<a href="#">EtherNet/IP for SNAP PAC Protocol Guide</a>	1770
Moving to the SNAP PAC System with older hardware and software	<a href="#">SNAP PAC System Migration Technical Note</a>	1688

<sup>1</sup> If you are using a SNAP PAC controller with legacy I/O units (for example, *mistic* I/O units or Ultimate I/O), use the Legacy versions of these documents instead:

- [Legacy Edition, PAC Control User's Guide](#), form 1710
- [Legacy Edition, PAC Control Command Reference](#), form 1711
- [Legacy Edition, PAC Manager User's Guide](#), form 1714

## FOR HELP

If you have problems installing or using SNAP PAC R-series controllers and cannot find the help you need in this guide or on our website, contact Opto 22 Product Support.

**Phone:** 800-TEK-OPTO (800-835-6786 toll-free in the U.S. and Canada)  
951-695-3080  
Monday through Friday,  
7 a.m. to 5 p.m. Pacific Time

*NOTE: Email messages and phone calls to Opto 22 Product Support are grouped together and answered in the order received.*

**Email:** [support@opto22.com](mailto:support@opto22.com)

**Opto 22 website:** [www.opto22.com](http://www.opto22.com)

When calling for technical support, be prepared to provide the following information about your system to the Product Support engineer:

- Version of this product
- PC configuration (type of processor, speed, memory, operating system)
- Complete description of your hardware system, including:
  - Jumper configuration
  - Type of power supply
  - Types of I/O units installed
  - Controller firmware version
  - Specific error messages

# 2: Installation

If you already know how you will use the SNAP PAC R-series controller and want to get it running quickly, follow the sections in this chapter.

To learn about communication options and networking, start on [page 13](#). Specifications are listed on [page 27](#).

## WHAT YOU WILL NEED

You'll need the following items to install a SNAP PAC R-series controller:

- A PC running Microsoft® Windows® 10 Professional (32-bit or 64-bit)
- **For an Ethernet connection**, the PC also needs a 10/100 MB Ethernet adapter card, the TCP/IP protocol installed, and a valid IP address, on the same subnet as the controller. (For more information, see [“Networking” on page 22](#).) In addition, you need a standard Ethernet cable for direct connection to the PC (recommended), or an available connection to a standard 10BASE-T or 100BASE-TX Ethernet network.
- SNAP PAC R-series controller
- SNAP PAC mounting rack and SNAP I/O modules. Choose rack and modules based on your needs. (Exception: a SNAP-PAC-R1-B uses a B-series rack, not a SNAP PAC rack.)
- A SNAP-PS5 or SNAP-PS5U power supply or other 5 VDC power supply (5.0 to 5.2 VDC at 4.0 A) applied to the rack. Additional power may be required for SNAP I/O modules and depends on the number and type of modules used. For more information, see [“Determining Power Requirements” on page 61](#).
- (Recommended) [PAC Project Basic](#) or [PAC Project Professional](#) (available from the Opto22 website)

## INSTALLING HARDWARE

Assemble the rack and power supply according to the directions that came with them. For help with wiring, see the product data sheets, which are available on our website at [www.opto22.com](http://www.opto22.com).

### Installing Modules on the Rack

**CAUTION:** Make sure you are using the correct rack for your controller. All SNAP PAC R-series controllers except the SNAP-PAC-R1-B use a SNAP PAC rack. SNAP-PAC-R1-B uses a B-series rack (with a B in the part number; this controller does not work on a SNAP-D64RS rack). Using the wrong rack will severely damage the controller.

Modules snap into position in the row of connectors on the SNAP PAC rack. Each module connector has a number.

*NOTE: R-series controllers with serial numbers lower than 600,000, and all SNAP-PAC-R1-B controllers, are limited to eight 4-channel digital modules per rack, located in the first eight positions.*

## INSTALLING HARDWARE

1. Place the rack so that the module connector numbers are right-side up, with zero on the left.

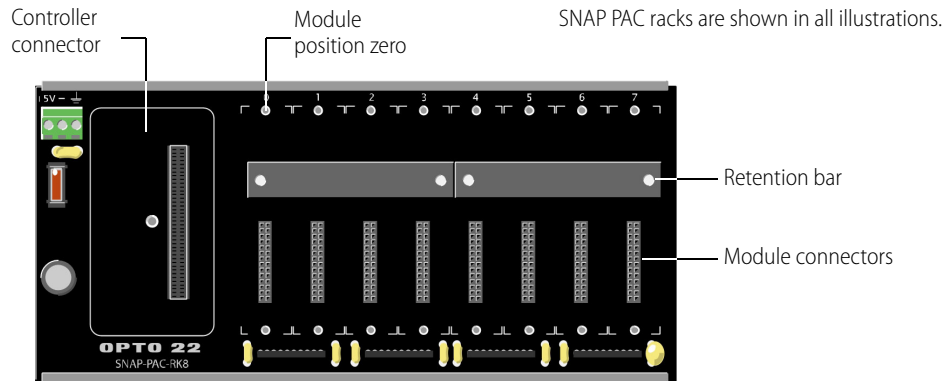

2. Position the module over the module connector, aligning the small slot at the base of the module with the retention bar on the rack.
3. With the module correctly aligned over the connector, push on the module to snap it into place.

When positioning modules next to each other, be sure to align the male and female module keys (shown in the detailed view in the illustration at right) before snapping a module into position. Modules snap securely into place and require a special tool (provided) to remove them. To remove a module, see the next section.

4. (Optional) Use standard 4-40 x 1/4 truss-head Phillips hold-down screws to secure both sides of each module. *Do not overtighten screws.*
5. Plug the wiring connector into each module to attach modules to the devices they monitor.  
See the wiring diagrams in the module's data sheet.
6. Continue with "Installing the Controller" on page 9.

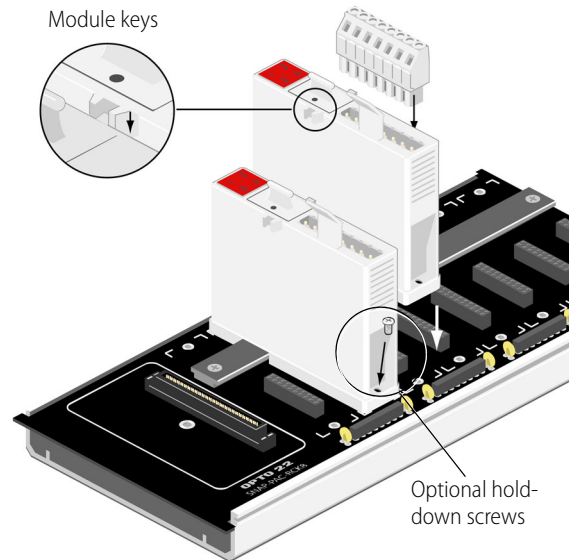



### Removing a Module

1. If the modules are held in place with screws, remove them.
2. Holding the SNAP module tool (provided) as shown in the illustration at right, insert it into the notch at the base of the module.
3. Squeeze the module tool against the module to open the release latch, and pull straight up on the module to remove it.

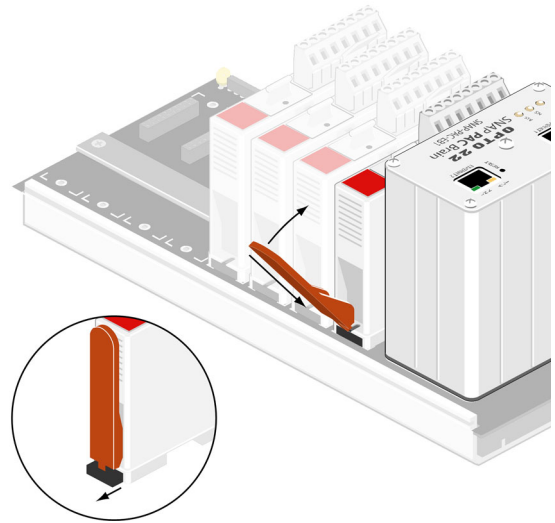

### Installing the Controller

**CAUTION:** Make sure you are using the correct rack for your controller. All SNAP PAC R-series controllers except the SNAP-PAC-R1-B use a SNAP PAC rack (or a legacy SNAP M-series rack). SNAP-PAC-R1-B uses a B-series rack (with a B in the part number; this controller does not work on a SNAP-D64RS rack). Using the wrong rack will severely damage the controller.

1. Remove the controller from its packaging.
2. Turn off power to the rack assembly.
3. Align the controller connector with the mating connector on the mounting rack.
4. Seat the controller onto the connector and use the hold-down screw to secure the controller in position. Torque: 8 lbf-in (0.9 N-m). Do not overtighten.
5. Using Category 5 or superior solid unshielded twisted-pair cable, connect the controller in one of the following ways:
  - (Recommended for initial configuration)  
Connect to a PC directly, using a standard Ethernet cable.
  - Connect to a standard 10BASE-T or 100BASE-TX Ethernet network that has a PC on the same subnet as the controller and does NOT have a Dynamic Host Configuration Protocol (DHCP) server.

*NOTE: When connecting the controller to a managed switch, make sure the managed switch's port configuration is set to Auto for the Duplex setting and Auto for the Speed setting.*

Maximum cable or segment length is 100 meters; minimum cable length is one meter.

6. See the Appendix (page 59) for information on power supplies and wiring.
7. **Before** turning on power to the controller, follow steps in the *PAC Manager User's Guide* (form 1704) to assign the controller an IP address.
8. **For controllers used with a modem:** Follow the steps in "Using PPP Over a Modem" on page 11.

## WHAT'S NEXT?

To start configuring controllers and I/O points, see “[Configuring I/O](#),” below.

To learn more about SNAP PAC R-series controller capabilities and network options, see [Chapter 3: System Information](#).

To create PAC Control strategies to run on the controller, see the [PAC Control User's Guide](#) (form 1700) and the [PAC Control Command Reference](#) (form 1701). Both are available in PDF format and you can download them free from our website, [www.opto22.com](http://www.opto22.com).

To securely access data from I/O points and strategy variables in the PAC via its RESTful API (application program interface based on the REST architecture), see [developer.opto22.com](http://developer.opto22.com).

To work with the following items on the controller, see instructions in the [PAC Manager User's Guide](#):

- File system and FTP
- Security settings
- Port and interface configuration

To use OLE for process control (OPC) with SNAP PAC R-series controllers, purchase OptoOPCServer and see the [OptoOPCServer User's Guide](#) (form 1439).

To communicate with controllers using Modbus/TCP, see the [Modbus/TCP Protocol Guide](#) (form 1678).

To communicate with an Allen-Bradley Logix PLC or other system using EtherNet/IP, see the [EtherNet/IP for SNAP PAC Protocol Guide](#) (form 1770).

To program your own applications, see the [OptoMMP Protocol Guide](#) (form 1465).

### Configuring I/O

No matter how you communicate with SNAP PAC R-series controllers, you will need to configure I/O points and controller features.

**If you are not using PAC Control** (Opto 22's flowchart-based control software), follow instructions in the [PAC Manager User's Guide](#) (form 1704).

**If you are using PAC Control**, I/O units and points must be configured to match the PAC Control strategy you will run. You can configure most controller features and point functions either in PAC Control or in PAC Manager.

In most cases, if you are already in PAC Control, configuration is easier there and you can use the loopback IP address for SNAP PAC R-series controllers controlling themselves. However, some functions cannot be configured in PAC Control.

If you use PAC Manager, you can save your configuration to a file, load it to multiple I/O units at once, and use it for referencing points in OPC. You can also configure some controller features that are not available in PAC Control. However, you cannot use the loopback address in PAC Manager.

See the table on the next page for a summary of which tool to use, based on your application.

Choose your configuration tool based on what you need to do:

Use PAC Control for I/O configuration if...	Use PAC Manager for I/O configuration if...
<ul style="list-style-type: none"> <li>You have only one I/O unit or I/O unit configurations are different.</li> <li>The strategy will run on I/O units that are controlling themselves using the loopback IP address (127.0.0.1).</li> <li>You are using an Ethernet network for communications.</li> <li>The strategy handles all logic; you are not also configuring events and reactions on I/O units.</li> </ul>	<ul style="list-style-type: none"> <li>You have multiple I/O units whose configurations are exactly the same or similar.</li> <li>You are using a modem connection (PPP) or SNMP.</li> <li>You are using event messages or email.</li> <li>You are configuring events and reactions on the I/O unit in addition to strategy logic.</li> <li>You are using OPC to communicate with I/O units.</li> <li>You are not using PAC Control.</li> </ul>

**IMPORTANT:** Whichever tool you use for configuring I/O, be aware of the impact if you later change configuration. For example, if you configure I/O in PAC Manager, download the configuration file to I/O units, and then later add a point in PAC Control, remember that your configuration file doesn't contain that point.

## USING PPP OVER A MODEM

Use the rest of this chapter only if you have SNAP PAC R-series controllers installed at remote locations or in other places where an Ethernet network is not available, and you are using modems to communicate between the controller and a PC. The modems use the point-to-point protocol (PPP) to communicate. You can set up communication so that the controller can dial in to a PC, so that PCs can dial into the controller, or both.

### PC dials in to controller

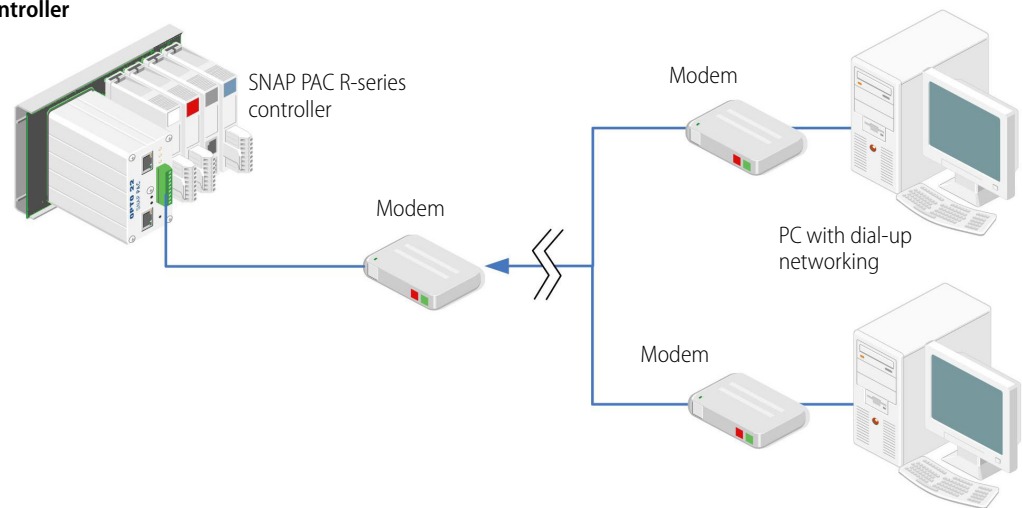

*NOTE: You can communicate with a SNAP PAC R-series controller using a modem and PPP at the same time you are communicating with the controller over an Ethernet network.*

Here's how to set up PPP:

1. Use PAC Manager to assign an IP address to the SNAP PAC R-series controller, following the instructions in the *PAC Manager User's Guide*.
2. Follow steps in the next section to configure PPP.
3. Attach the modem to the system, following the steps below.
4. Set up Windows dial-up networking on the PC.

### Configuring PPP on the Controller

To configure PPP on the SNAP PAC R-series controller, see instructions in the [PAC Manager User's Guide](#) (form 1704). Also use this guide to assign an IP address to the Ethernet ports, configure points, and store configuration to flash.

### Attaching the Modem to a SNAP PAC R-Series Controller

Once the controller and I/O points are configured and communication has been tested, follow these steps to attach the modem to the controller. To work properly with the controller, a modem must be able to store settings in non-volatile RAM (NVRAM) and default to those settings on reset.

*IMPORTANT: Any modem used with the controller must implement the Carrier Detect (CD) signal or use a custom cable that connects CD to Data Terminal Ready (DTR) on the controller side.*

1. Use the following diagram to attach the modem to the controller using the serial connector. As shown here, you can use either a DB9 or a DB25 connection.

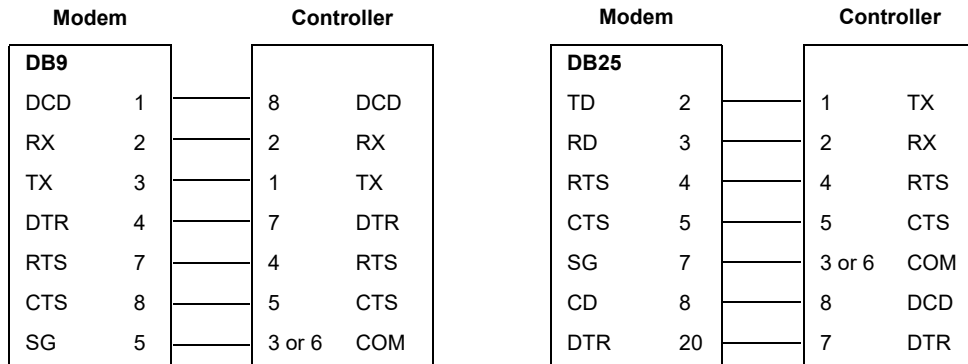

*NOTE: Pins 3 and 6 are tied together within the SNAP PAC R-series controller, so no external jumper is required.*

2. Store configuration settings to the modem's NVRAM, following instructions in the user's guide for your modem.

*NOTE: Configuration settings must be stored to the modem's NVRAM so they will be loaded when the SNAP PAC R-series controller sends a reset command to the modem.*

3. If PCs will dial up the controller, set up Windows dial-up networking on the PCs that will call the controller.

# 3: System Information

This chapter explains how to use SNAP PAC R-series controllers in an Ethernet network and how to communicate with them. It also provides information on system architecture, specifications, and features.

## In This Chapter

Communication Options.....	13
System Architecture.....	16
Networking.....	22
Specifications, Connectors, and Dimensions.....	27
Information on Features.....	30
SNAP-PAC-R1 and -R2 Comparison Chart.....	33

## COMMUNICATION OPTIONS

SNAP PAC R-series controllers communicate using TCP/IP or UDP/IP over an Ethernet network.

**Physical Layer**—All SNAP PAC R-series controllers communicate over a 10- or 100-Mbps wired Ethernet link. SNAP PAC R-series controllers can also communicate using a modem over PPP.

**Transport Layer**—The key to SNAP PAC R-series controller communication flexibility is the transport layer, Internet Protocol (IP). Both the Transmission Control Protocol (TCP) and the User Datagram Protocol (UDP) are used with IP.

**Application Layer**—Because SNAP PAC R-series controllers use standard IP for the transport layer, many communication options are possible in the application layer. After the controller is installed and has an IP address assigned (see [page 9](#)), you can communicate with it using the following methods:

- **PAC Manager** software utility is used for assigning IP addresses, configuring I/O points and features, and performing onetime reads and writes.
- **PAC Control** strategies running on a *groov* EPIC or SNAP PAC System industrial controller can configure, read, and write to I/O points on R-series controllers.
- **Custom applications using the PAC's RESTful API and HTTP/HTTPS server** let you securely access data using the language of your choice, including PHP, JavaScript, .NET, Perl, and others. Data is returned as JSON. See the API and instructions at [developer.opto22.com](http://developer.opto22.com).
- **Custom software applications** can also be built using our OptoMMP Software Development Kits (SDKs) for C++ and .NET. They use OptoMMP, an IEEE 1394-based protocol, to read and write to SNAP PAC R-series controllers. The C++ SDK supports Linux® and Windows® platforms; the .NET SDK is for Windows. For developers not using Microsoft Windows, the OptoMMP protocol is open and documented.
- **EtherNet/IP** provides communication with Allen-Bradley ControlLogix® and CompactLogix™ PLC systems and other systems using the EtherNet/IP protocol. Both implicit and explicit messaging are supported.

- **Modbus/TCP** provides a direct connection with Modbus/TCP hardware or software or third-party software applications, which can read or write to I/O points on SNAP PAC R-series controllers.
- **OPC** (OLE for Process Control) uses OptoOPCServer to serve controller data to any OPC 2.0-compliant application, such as an HMI, which can also read or write to I/O points. OptoOPCServer can be purchased separately or as part of the PAC Project Professional software suite.
- **SMTP** (Simple Mail Transfer Protocol) connects a SNAP PAC R-series controller with corporate email servers, so employees can be emailed or paged if there's a problem on devices attached to the controller.
- **SNMP** (Simple Network Management Protocol) makes it possible to monitor devices attached to SNAP PAC R-series controllers just as you would any computer or server on the Ethernet network, using an SNMP-based enterprise management system such as Computer Associates' Unicenter<sup>®</sup>, Hewlett-Packard's OpenView<sup>®</sup>, or IBM's Tivoli<sup>®</sup>. When a monitored event occurs, such as a door left open or a pressure level too high, the controller sends an SNMP trap to the management system.
- **FTP** (File Transfer Protocol) can be used to transfer files and data to and from the SNAP PAC R-series controller, whether to custom applications, enterprise databases, or any file system. R-series controllers manufactured after November 2008 include removable storage capability: a microSD card slot. See [page 37](#) for information on using the card for storage and for loading firmware or PAC Control strategies to the controller.

### Simultaneous Communication

In addition to communicating using all the methods listed above, each SNAP PAC R-series controller can also communicate *simultaneously* using all applicable methods.

The reason lies in the nature of IP. In serial communication, a single data request is sent by one device to another. The first device must wait for a response before any additional communication can be carried out. IP, however, can establish multiple simultaneous sessions, so many data requests can be sent at once without waiting for any individual response. Each request gets a response, but the link isn't idle while waiting for responses.

In addition, IP can simultaneously handle multiple requests from multiple devices. A PC can communicate with all SNAP PAC R-series controllers on the same network—all at the same time—and multiple PCs can communicate with one controller at the same time.

So, for example, a SNAP PAC R-series controller can respond to directions from a Modbus master, give analog point data to a technician using PAC Manager, and carry out instructions from a custom C++ application—all at once.

### Accessing SNAP R-Series Controllers over the internet

Since SNAP PAC R-series controllers are just like any other hardware on the Ethernet network, you can access them over the internet in exactly the same way you would access a computer. The details depend on your network and internet connection. Consult your system or network administrator or your Internet Service Provider (ISP) for more information. Also see the [Guide to Networking Opto 22 Products](#) (form 1796).

## Choosing Communication Methods

How do you need to communicate with SNAP PAC R-series controllers to match the tasks your application requires? Check the following table for help in choosing communication methods and finding more information on them.

This task	Can be done using these methods		Details and references for information
	Recommended	Alternate	
Configure controllers.	PAC Manager (I/O points and other functions) or PAC Control (I/O points only) For A-B systems, use EtherNet/IP Configurator.	OptoMMP Software Development Kit or IEEE 1394-based protocol.	If you are using PAC Control, configure the system in PAC Control configure mode. See the <i>PAC Control User's Guide</i> . For A-B systems, see <i>EtherNet/IP for SNAP PAC Protocol Guide</i> . For the Software Development Kit or IEEE 1394-based protocol, see <i>OptoMMP Protocol Guide</i> .
Monitor and control processes.	PAC Control flow-chart logic	PAC Manager Inspect window or OptoMMP Software Development Kit or IEEE 1394-based protocol	See <i>PAC Control User's Guide &amp; Command Reference</i> . CAUTION! Events and reactions set up using alternate methods are faster than flowchart logic, but be careful if you use them. They can conflict with PAC Control logic, because both write to the controller's memory map. For Software Development Kit or IEEE 1394-based protocol, see <i>OptoMMP Protocol Guide</i> .
Send email to or page someone. Send SNMP trap. Monitor devices through an enterprise management system.	PAC Manager (for configuration), PAC Control	OptoMMP Software Development Kit or IEEE 1394-based protocol	If you are using PAC Control, configure email using PAC Manager. See the <i>PAC Manager User's Guide</i> . For Software Development Kit or IEEE 1394-based protocol, see <i>OptoMMP Protocol Guide</i> .
Give technicians an Opto 22 HMI with alarming and trending.	PAC Display		See <i>PAC Display User's Guide</i> .
Give technicians a mobile operator interface for monitoring and controlling systems/equipment	<i>groov</i> View		Requires <i>groov</i> Server for Windows or a <i>groov</i> EPIC processor.
Monitor and control SNAP PAC R-series controllers on the network.	PAC Control	Other programming tool with <i>groov</i> EPIC processor	PAC Control with a <i>groov</i> EPIC, SNAP PAC R-series, or SNAP PAC S-series controller (see <i>PAC Control User's Guide &amp; Command Reference</i> ) See <i>groov</i> EPIC system.
Share strategy variable data with Opto 22 controllers and other SNAP PAC R-series controllers (peer-to-peer communication).	PAC Control (writes to memory map Scratch Pad areas)	Memory map Scratch Pad areas	PAC Control does not write directly to peers, but places data in the memory map so peers can retrieve it by reading memory map addresses. See <i>PAC Control User's Guide &amp; Command Reference</i> . Also see controller's memory map in <i>OptoMMP Protocol Guide</i> .
Securely access I/O point and variable data for use in databases, other systems, or internet of things (IoT) applications	PAC's RESTful API and HTTP/HTTPS server	IoT software built into <i>groov</i> EPIC processor	See the API and instructions at <a href="http://developer.opto22.com">developer.opto22.com</a> . See <i>groov</i> EPIC system.
Communicate with Modbus/TCP hardware or software.	Modbus/TCP		See the <i>Modbus/TCP Protocol Guide</i> (form1678).
Communicate with Allen-Bradley Logix PLC systems	EtherNet/IP		See the <i>EtherNet/IP for SNAP PAC Protocol Guide</i> (form 1770).
Exchange I/O point data with third-party software such as HMIs.	OptoOPCServer and controller's memory map	IoT software built into <i>groov</i> EPIC processor	Purchase OptoOPCServer separately. See <i>OptoOPC-Server User's Guide</i> and the memory map in <i>OptoMMP Protocol Guide</i> . See <i>groov</i> EPIC system.

This task	Can be done using these methods		Details and references for information
	Recommended	Alternate	
Exchange PAC Control strategy variable data with third-party software such as HMIs.	FTP and controller's file system	OptoOPCServer or built-in IoT software in <i>groov</i> EPIC	Purchase OptoOPCServer separately. See <i>PAC Control User's Guide</i> and <i>OptoOPCServer User's Guide</i> . See <a href="#">groov EPIC system</a> .
Write your own software application to communicate with the system.	C++ or Active X: OptoMMP Communication Toolkit and controller's memory map.	Opto 22's IEEE 1394-based protocol and controller's memory map.	See <i>OptoMMP Protocol Guide</i> .

## SYSTEM ARCHITECTURE

Because SNAP PAC R-series controllers are a combination of controller and I/O processor, their architecture is more complex than that of devices such as the SNAP EB-series brains, which are I/O processors only. The next few pages show the capabilities of this versatile system, starting with the simplest and moving to the more complex. Your application may require only some of these capabilities, but as your needs expand, remember that SNAP PAC R-series I/O can be used in all the ways shown, *simultaneously*.

### Understanding the SNAP PAC R-series Controller

The SNAP PAC R-series controller merges two functions that are usually located in separate pieces of hardware: input/output processing and flowchart-based control. These two functions are handled by two "sides" of the controller, as illustrated below.

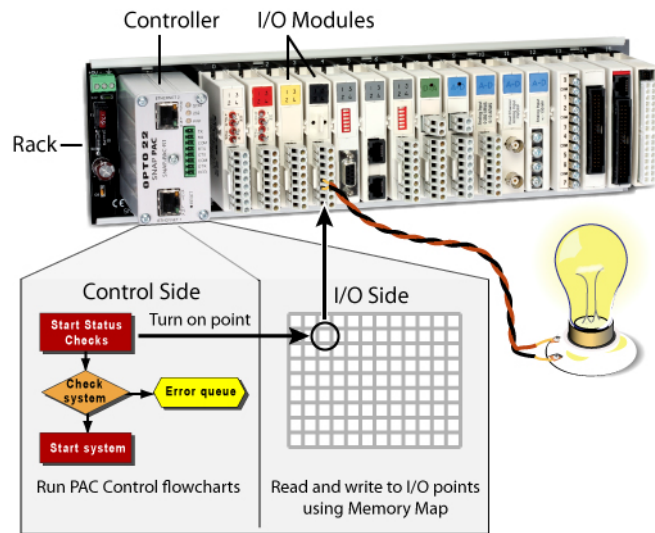

The rack is shown with the SNAP PAC R-series controller on the left and the input/output modules on the right.

The modules on the rack connect to devices in the real world, such as the light bulb, to monitor or control them.

#### The I/O Side of the Controller

The controller reads and writes to the I/O points using its I/O side memory map. This side of the SNAP PAC R-series controller is like SNAP EB-series brains.

You can think of the controller's memory map as a grid of mailboxes, with each mailbox having its own memory address. Each mailbox address has a specific purpose. For example, one address holds the state of a single digital point; another address holds counter data for the same point. There's an address that stores the controller's firmware version, one that contains the minimum value of a specific analog point, and many more.



If you are familiar with programmable logic controllers (PLCs), you'll see that the memory map is similar to a register.

Most SNAP PAC R-series controllers run PAC Control flowcharts that automatically manipulate the memory map, so you probably won't need to understand it in detail. If you do need to refer to it, however, the complete list of memory map addresses is in the [OptoMMP Protocol Guide](#), (form 1465).

### The Control Side of the Controller

The control side of the controller is like a traditional Opto 22 industrial controller. In the control side, the controller runs PAC Control flowcharts. These flowcharts provide the logic that controls processes through the system. Commands within the flowchart read from and write to the memory map in the I/O side of the controller in order to monitor and control the I/O points.

### Controlling the System

The flowcharts that run in the control side of the controller are created in PAC Control, a software application included with the SNAP PAC R-series controller. You create these flowcharts as part of a *control strategy* and download the strategy to the controller, and the controller runs it independently. For information on using PAC Control, see the [PAC Control User's Guide](#) (form 1700) and the [PAC Control Command Reference](#) (form 1701).

You use PAC Control on a PC connected to the network, so you can create your control strategy and download it to the controller. Also included with the SNAP PAC R-series controller is PAC Display, a full-featured human-machine interface (HMI). PAC Display uses the same tag database as PAC Control, so points and variables are already defined. Operators, technicians, and engineers running PAC Display on a Microsoft Windows-based PC on the Ethernet network can see the information they need, as well as plot trends and respond to alarms.

For applications that require more than one I/O unit, the SNAP PAC R-series controller can control multiple I/O units through the flowcharts on its control side. These I/O units can be located where needed on the Ethernet network for distributed control.

The following diagram shows the control side of the controller:

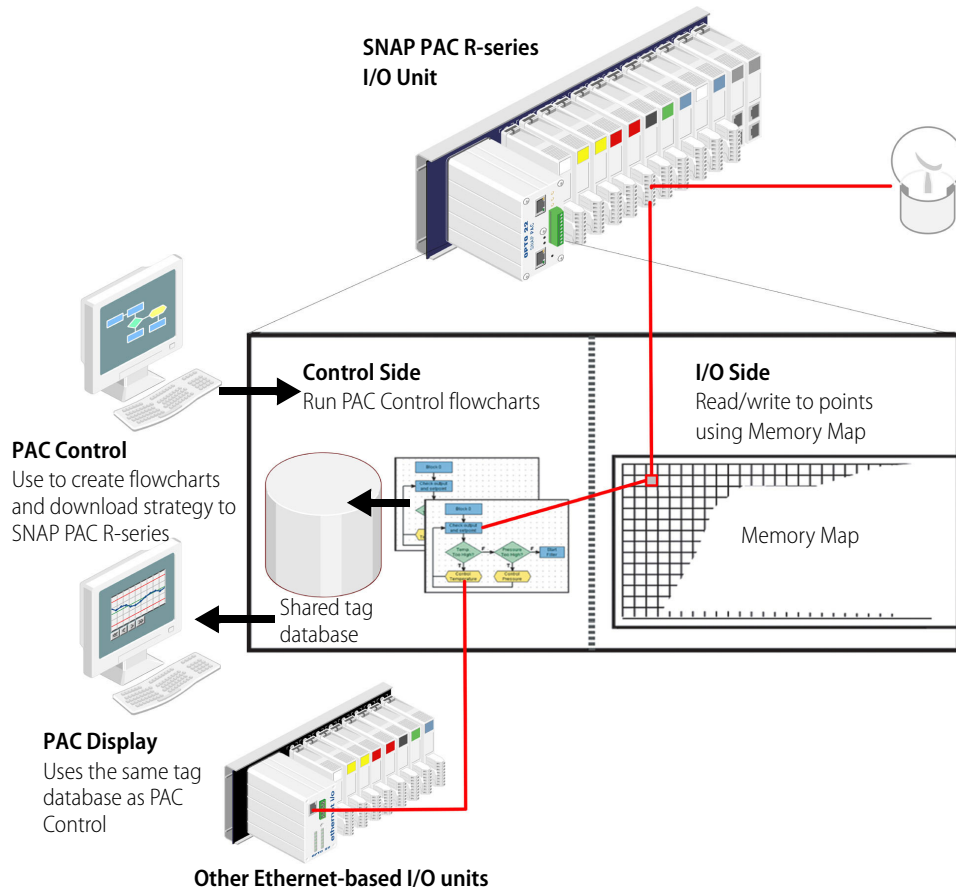

### Using Data for Peer-to-Peer Communication

What if you have multiple SNAP PAC controllers? What if each one is running a different PAC Control strategy, and they need to share variable data? Or what if you need to share data between a SNAP PAC System and an Allen-Bradley Logix-based PLC?

Scratch Pad areas within the SNAP PAC R-series controller’s memory map provide a way for other devices on the Ethernet network to access data in the controller. For descriptions of the Scratch Pad areas—bits, integers, floats, and strings—see the *PAC Manager User’s Guide*. For help in using PAC Control commands to access Scratch Pad areas, see “I/O Unit—Scratch Pad Commands” in Chapter 10 of the *PAC Control User’s Guide*. For information on communicating with an A-B Logix PLC, see the *EtherNet/IP for SNAP PAC Protocol Guide*.

The following illustration shows how this type of peer-to-peer communication can be done using PAC Control.

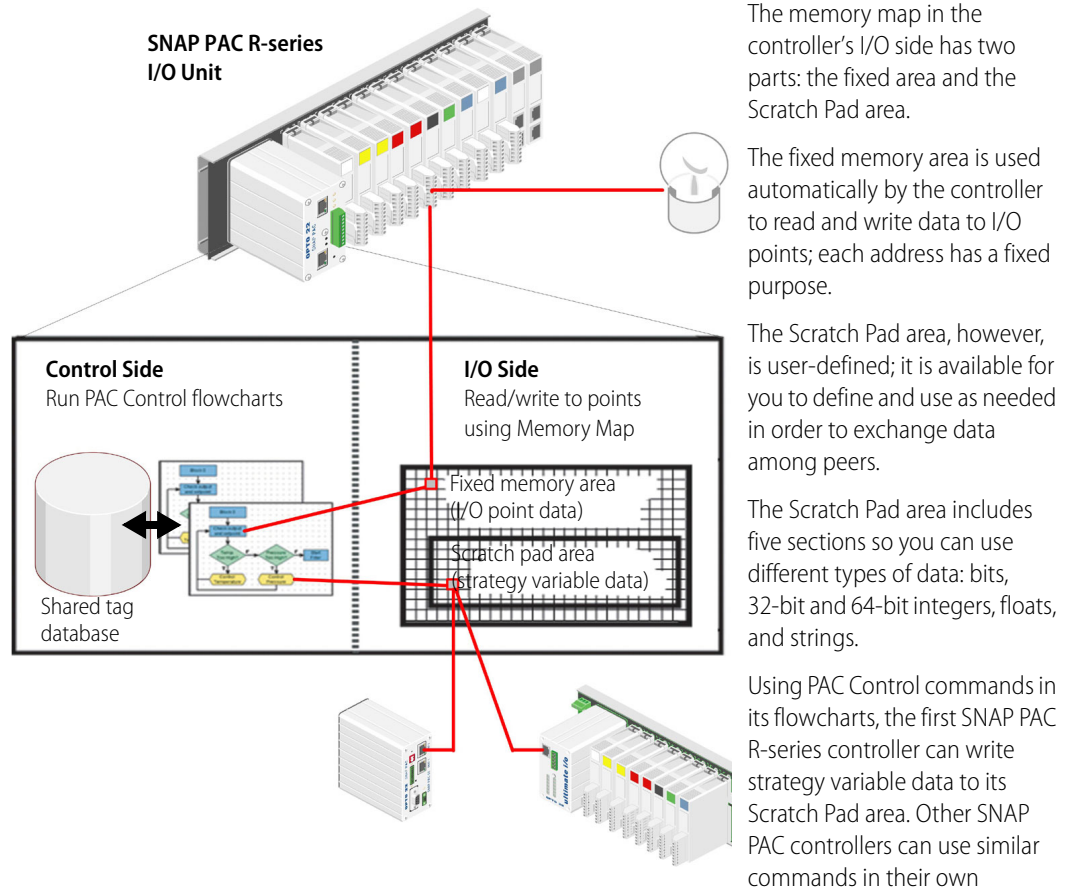

flowcharts to read the data from the Scratch Pad area of the first controller. Similarly, another unit or controller can write to the Scratch Pad area of the first controller, which can then read the data deposited in its own Scratch Pad area by the peer. The reading and writing of data by peers to the Scratch Pad area must be very carefully coordinated in order to avoid conflicts.

For more information on using PAC Control commands for peer-to-peer communication, see "Communication Commands" in Chapter 10 of the *PAC Control User's Guide* and individual commands in the *PAC Control Command Reference*.

If you are not using PAC Control but writing your own software applications to access the Scratch Pad areas, see the *OptoMMP Protocol Guide*. This guide is written for I/O units, but much of the same information on programming applies to SNAP PAC controllers. The Scratch Pad areas of the memory map are described in the programming guide's appendix.

### Communicating with Enterprise Systems and Third-Party Software

In addition to its capabilities in I/O, control, and peer-to-peer communication, the SNAP PAC R-series I/O system can also interface directly with enterprise systems and third-party software that need to use its data.

The following graphic shows how these software applications (and some hardware, too) can directly access the memory map in the controller's I/O side for both I/O point data and strategy variable data.

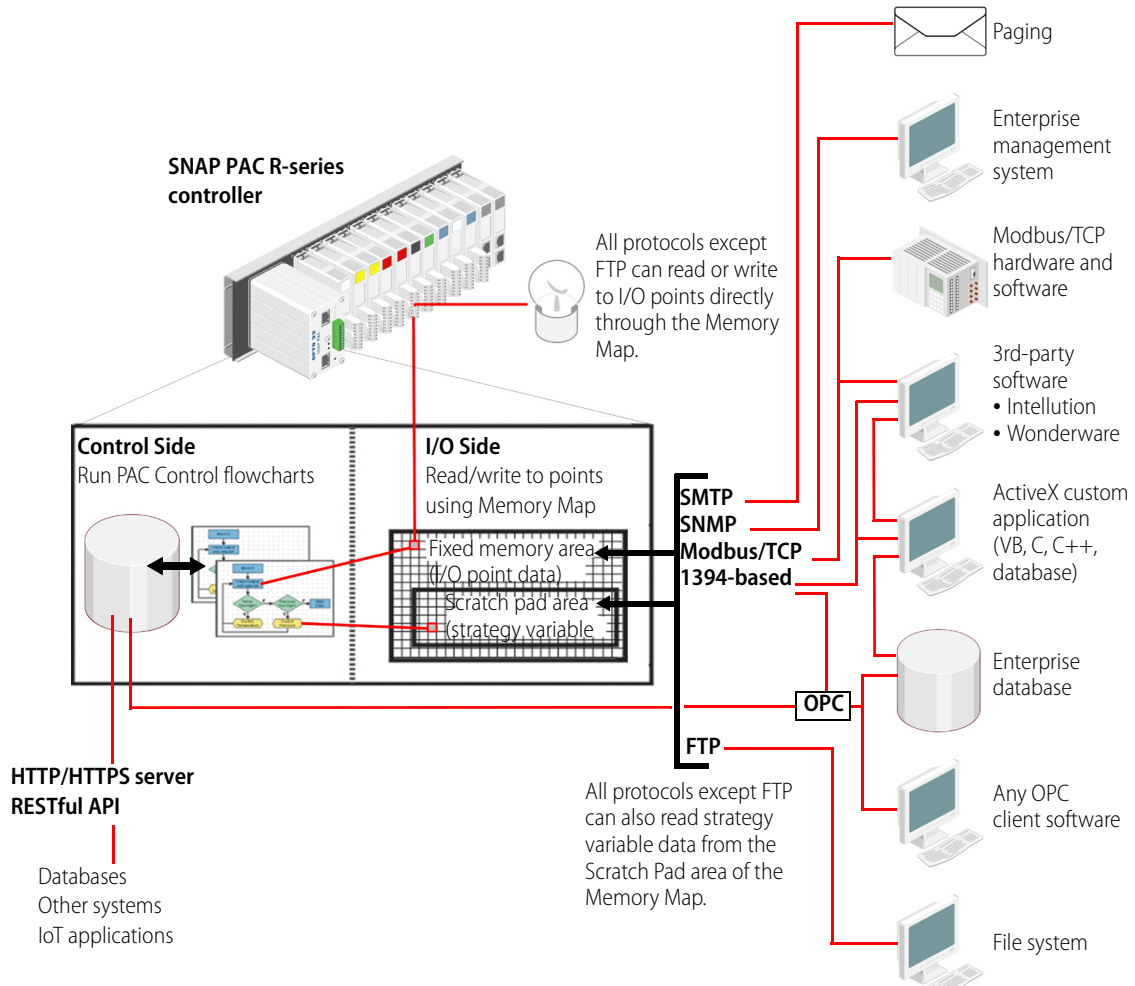

All of the protocols shown in the diagram, except FTP, can be used to communicate with both the fixed memory map area and the Scratch Pad area, so you can access both I/O point data in the fixed area and strategy variable data placed in the Scratch Pad area. In addition, strategy variable data from the PAC Control database can be directly used by OPC clients.

FTP can be used to access files on the SNAP PAC R-series controller, which are on the control side but can contain data from the I/O side (or any other data). For more information on the controller's file system and FTP, see the *PAC Control User's Guide* and the *PAC Manager User's Guide*.

### The Complete System

When all these capabilities we've discussed are put together, you can see the versatility—and the wealth of applications—of the SNAP PAC R-series I/O system, shown on the following page.

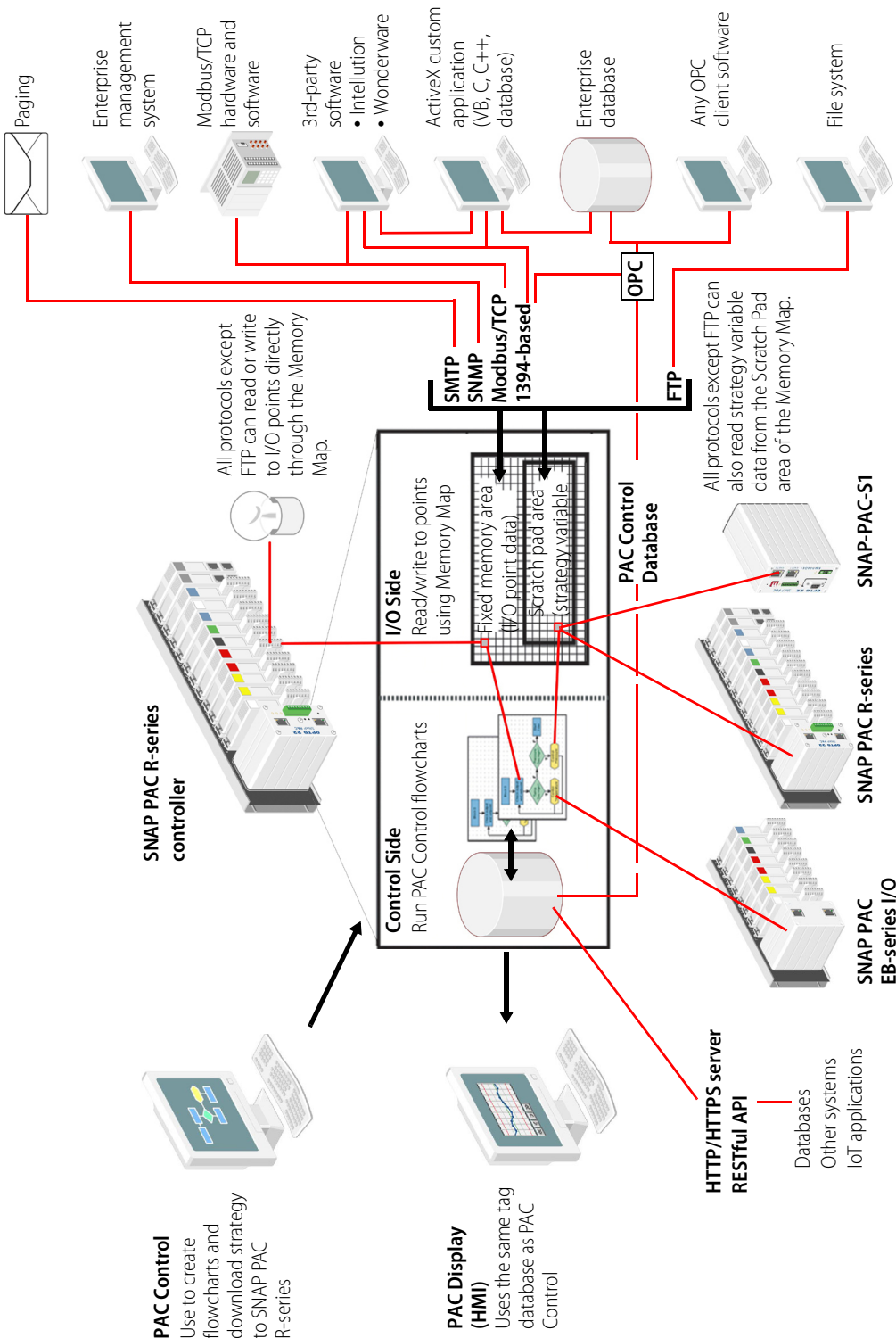

Other Opto 22 controllers can read strategy variable data from the Scratch Pad area.

Since all protocols can be used simultaneously, while the strategy is running on the control side of the controller and peer-to-peer communication is going on, coordination in accessing data through the REST API or reading and writing to memory map areas is critical to avoid conflicts. The more capabilities of the system you use, the more careful you must be in planning.

## NETWORKING

From a physical standpoint, SNAP PAC R-series controllers can be networked in several ways:

- Connected directly to a PC or controller using a standard Ethernet cable
- Attached to an existing TCP/IP Ethernet network
- As part of an independent network built with standard Ethernet hardware
- Over a modem connection

The networking method you use depends on several things, including whether you need control or data acquisition, the number of PCs, controllers, and I/O units you are using, the speed and volume of communication, security requirements, and the availability of an existing network. (For more information on networking, see the [Guide to Networking SNAP PAC Products](#), form 1796.)

### Connecting the Controller Directly to a PC or Master Controller

A direct connection connects just one SNAP PAC R-series controller with one host. The Ethernet interface(s) on the controller support Auto MDI-X, which means you can use a standard straight-through Ethernet cable; a crossover cable is not needed for direct connection to a PC.

A direct connection is quick, easy to do, and provides high speed and high security for a small system. It is useful for assigning an IP address, configuring I/O points, and testing applications on I/O units that will be used later on a network. The direct connection eliminates other variables that could interfere with communication, so you can focus on maintenance and troubleshooting.

### Attaching the Controller to an Existing Ethernet Network

The first rule in attaching SNAP PAC R-series controllers to an existing network is to work closely with your system administrator, who must determine network topology and hardware. Be sure to consider the impact on your existing network of adding the controllers.

In addition, make sure the system administrator understands that each controller must have a **fixed (static)** IP address, whether or not a Dynamic Host Configuration Protocol (DHCP) server is used on the network. For more information on IP addresses, see the *PAC Manager User's Guide*.

If you are using SNAP PAC R-series controllers for data acquisition, you can place the controller anywhere on an existing Ethernet network. If you are using the controller with control applications, however, the network design will depend on the number of hosts, the number of data transactions, and issues of data security. With fewer hosts and fewer data transactions, data packet collisions are less likely and system performance improves. If collisions are a problem, and especially if you need high throughput and predictable response times, it's best to put the controller on a separate switched network segment. We recommend switches, not hubs. For best performance, use a 100 Mbps network.

### Isolating the Control Network in a Separate Zone

*NOTE: This implementation requires PAC Project Professional. For more information, see the [SNAP PAC R-series data sheet \(form 1594\)](#) and the [SNAP PAC S-series data sheet, form 1584](#). You may also consider using a router, network switch, or other gateway device.*

If you need to isolate your trusted control system network from an untrusted network (for example, a company network that accesses the internet), you can use the two Ethernet interfaces on either the SNAP PAC R-series or an S-series controller to create separate zones. One interface can be connected to the trusted network, and the other used for the untrusted network. See the diagram on [page 25](#).

## Using the Controller in an Independent Network

The third way SNAP PAC R-series controllers can be used is by developing an independent network. An independent network gives a high level of communication speed and volume, as well as high security. If you have no existing Ethernet network, you can use off-the-shelf Ethernet components to build one. Consider using industrial-grade Ethernet components for harsh and challenging environments.

You may also need a separate network for critical control applications. Again, the choice depends on your requirements for data transactions, data security, and whether a near-deterministic system is necessary.

If you are building your own network, remember that each controller must have a **fixed** IP address. See the *PAC Manager User's Guide* for more information on IP addresses.

Since Ethernet and TCP/IP are worldwide standards, there are a number of commercially available resources for learning about building and maintaining such a network. We strongly suggest you learn as much as possible about the subject and plan your network carefully before beginning, in order to get the best performance from your system.

## Communicating with the System via Modem

A fourth way to use a SNAP PAC R-series controller is with a modem connection, useful for remote installations (for example, a communication tower or a pipeline) or in other places where a wired Ethernet network is not practical. Communication via modem uses the Point-to-Point Protocol (PPP) over an RS-232 link instead of an Ethernet link.

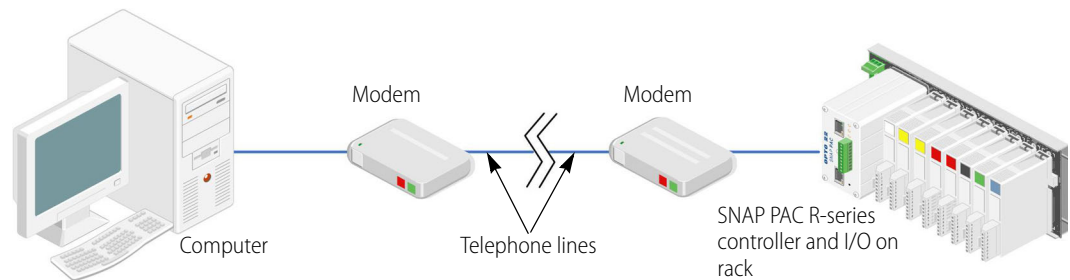

The system can dial out to a PC connected to a modem, or the PC can dial into the system, or both. If the system is also communicating via Ethernet, the network ID for the PPP interface on the controller must be different from the controller's Ethernet IP network ID.

For more details on configuring the controller for use with a modem, see [“Using PPP Over a Modem” on page 11](#).

## Network Architecture Diagrams

Because SNAP PAC R-series controllers have two Ethernet interfaces and an RS-232 serial interface, these controllers are suitable for use in a variety of system layouts and architectures. For example, the independent Ethernet interfaces let you configure a network for link redundancy or isolating networks into zones. As described in the previous section, the PPP serial interface provides a dial-up modem link for remotely located control systems. The serial interface can also be used to connect a serial device such as a barcode scanner.

Basic Control Network

The following diagram shows a SNAP PAC R-series controller that uses one network interface to communicate with host computers and control I/O. The controller controls I/O on its own rack and on other SNAP PAC I/O units.

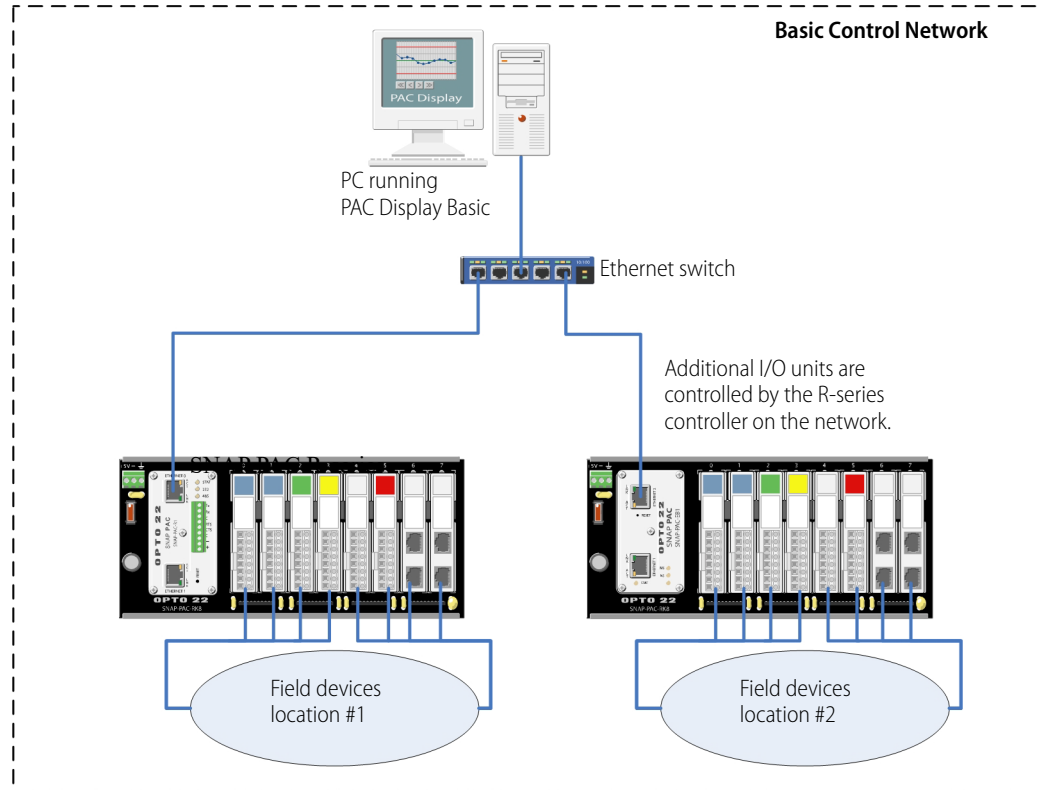



**Network Zoning: Ethernet Connections to Host and I/O Units**

The following diagram shows two Opto 22 I/O units connected together over an Ethernet network (a trusted network) and controlled by a SNAP PAC R-series controller running a PAC Control strategy.

The controller is also connected to a larger, separate enterprise Ethernet network (an untrusted network) to provide data to PCs running Opto 22's PAC Display HMI software, OptoOPCServer, and OptoDataLink. Sitting between the two networks, the SNAP PAC R-series controller isolates enterprise traffic from the control network, separating the two networks into zones.

The network shown in this diagram requires PAC Project Professional.

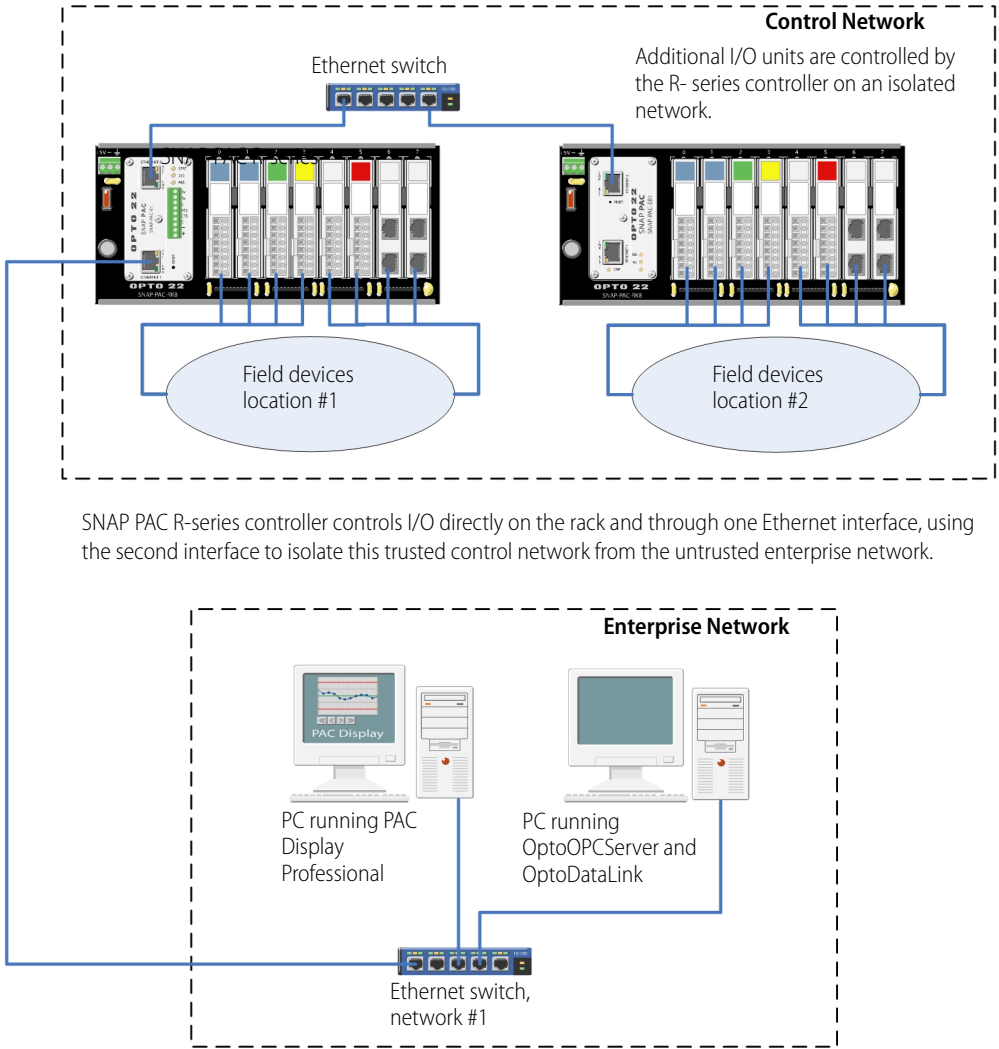

SNAP PAC R-series controller controls I/O directly on the rack and through one Ethernet interface, using the second interface to isolate this trusted control network from the untrusted enterprise network.

Ethernet Link Redundancy

The following diagram shows two SNAP PAC R-series controllers functioning as I/O unit brains connected to two separate Ethernet networks. This configuration addresses the concern that an Ethernet network may fail or need maintenance, leaving the PC running OptoOPCServer, the PC running PAC Display, the controller, and the I/O units unable to communicate. The network shown in this diagram requires PAC Control Professional, PAC Display Professional, and OptoDataLink.

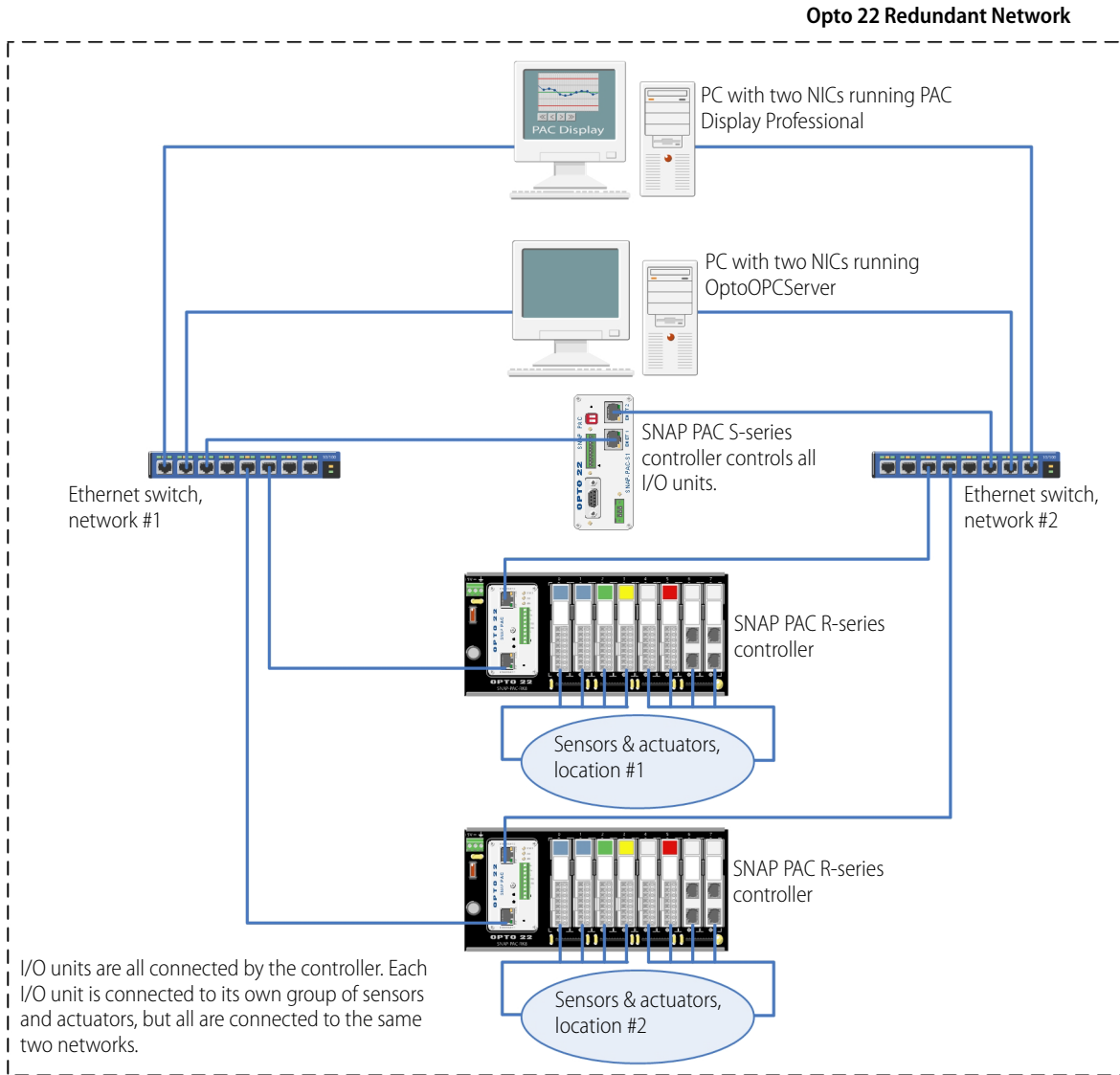

In this configuration, if one network goes down, devices can still communicate because the SNAP PAC S-series controller and the SNAP PAC R-series controllers both have two network interfaces, and each PC in this system has two network interface cards.

*NOTE: If you need controller redundancy (two controllers running concurrently, with one able to take over if the other fails), use SNAP PAC S-series standalone controllers with the PAC Redundancy Option Kit and PAC Control Professional. For more information, see the Opto 22 website.*

## SPECIFICATIONS, CONNECTORS, AND DIMENSIONS

### Specifications for SNAP-PAC-R1 and -R2 Controllers

Processor	200 MHz 32-bit ColdFire® 5475 with integrated floating-point unit (FPU)
Memory	
Total RAM	16 MB (5 MB available for PAC Control strategy and 2 MB for file storage)
Battery-backed RAM	2 MB (1 MB available for PAC Control strategy)
Flash	8 MB (3.25 MB available for PAC Control strategy; 384 KB available for file storage)
Removable storage	(Models with manufacture dates of November 2008 and newer. Requires firmware R9.4a or higher and loader R6.1a or higher) MicroSD card slot: supports microSD or microSDHC cards to 32 GB. (Note: Models with card slots and firmware R8.4 through R9.3e support microSD cards up to 2 GB only.)
Backup battery	Rechargeable (recharges whenever the brain has power), 3-year power-off data retention (replacement part number: SNAP-PAC-BATTERY-ML2430) <sup>1</sup>
Communication	
Ethernet	Two independent 10/100 Mbps Ethernet network interfaces (RJ-45 connectors). Each interface has a separate IP address. Connects to host and I/O. Supports Auto MDI-X (crossover cable not needed)
RS-232 serial	One RS-232 serial port <sup>2</sup> with hardware handshaking. Connects to host (via modem and PPP) or serial device. Cannot connect to serial I/O.
I/O unit compatibility	SNAP PAC I/O units: SNAP PAC R-series and EB-series I/O units <i>groov</i> RIO edge I/O units <i>groov</i> EPIC I/O units
Power requirements	5.0–5.2 VDC @ 1.5 A
Hold-down screw	Torque: 8 in-lb (0.9 N-m)
Connector screw	Torque: 1.7 in-lb (0.19 N-m)
Environmental	
Operating temperature	-20 °C to 60 °C
Storage temperature	-40 °C to 85 °C
Humidity	0% to 95% relative humidity, non-condensing
Software	
PAC Project Basic	Includes programming, HMI software, and configuration software; included with purchase of controller.
PAC Project Professional	PAC Project Basic plus OPC 2.0-compliant OPC server, database connectivity, OptoControl strategy and OptoDisplay project importing, and support for Ethernet link redundancy or network segmenting.
RESTful API <sup>3</sup>	Use HTTPS to access data (read/write or read-only) from controller tags using your chosen programming language. Data returned in JSON. More information at <a href="http://developer.opto22.com">developer.opto22.com</a>
Number of charts that can run simultaneously	16
Agency approvals and certifications	All models: DFARS, CE, RoHS All models except -FM models: UL (-FM and -B models only) Factory Mutual approved, ATEX
Warranty	30 months from date of manufacture
Other features	<ul style="list-style-type: none"> <li>• Multiple protocol support including TCP/IP, HTTP/HTTPS, FTP, EtherNet/IP, Modbus/TCP, SNMP v2.0c, OptoMMP™, and SMTP</li> <li>• Built-in I/O processor handles up to 16 digital<sup>4</sup>, analog, and serial I/O modules on the same rack</li> <li>• Real-time clock</li> <li>• FTP server/client with file system (in RAM and in removable storage)</li> <li>• Scratch Pad area for peer-to-peer communication</li> <li>• Configurable link redundancy or segmented networking</li> <li>• for I/O-controller subnetting (when using PAC Project Professional)</li> </ul>

<sup>1</sup> Models manufactured before July 1, 2007 have a user-replaceable 3-volt CR2032 Lithium battery (typical service life with power off: 5 years).

<sup>2</sup> Connecting to a serial device requires configuration in PAC Manager; PAC Control handles communication.

<sup>3</sup> Requires firmware R9.5a or higher.

<sup>4</sup> SNAP-PAC-R1s with serial numbers lower than 600,000, and all SNAP-PAC-R1-Bs, are limited to eight 4-channel digital modules per rack; remaining eight can be analog, serial, and high-density digital modules.

## Connectors and LEDs

The following information applies to all SNAP PAC R-series controllers. For LED blink codes, see [page 49](#).

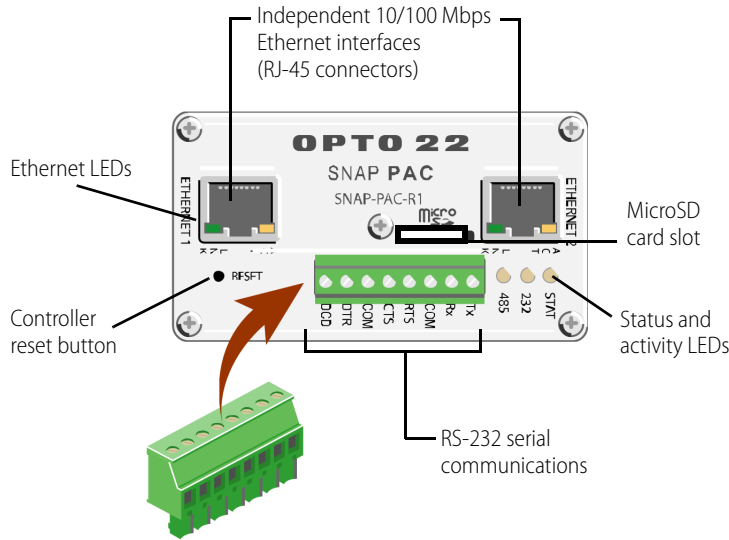

### RS-232 Port (Port 0)

Pin	Description
1	TX
2	RX
3	COM
4	RTS
5	CTS
6	COM
7	DTR
8	DCD

### Status and Activity LEDs

Indicator	Description
ACT	Ethernet network activity
LNK	Link established with Ethernet network
STAT	Startup status, control program operational status, MicroSD card access
232	RS-232 serial activity
PPP	PPP status

### RS-232 Serial Cable Wiring\*

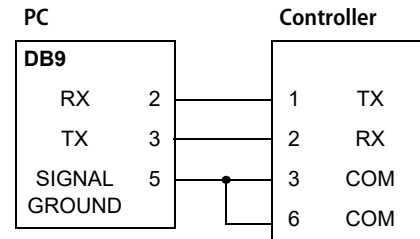

\* Minimum requirements for wiring an RS-232 serial cable to connect to a PC. If you want to connect the controller to a modem, see [page 12](#) for all eight pin connections.

### Dimensions

The dimensions are the same for all SNAP PAC R-series controllers.

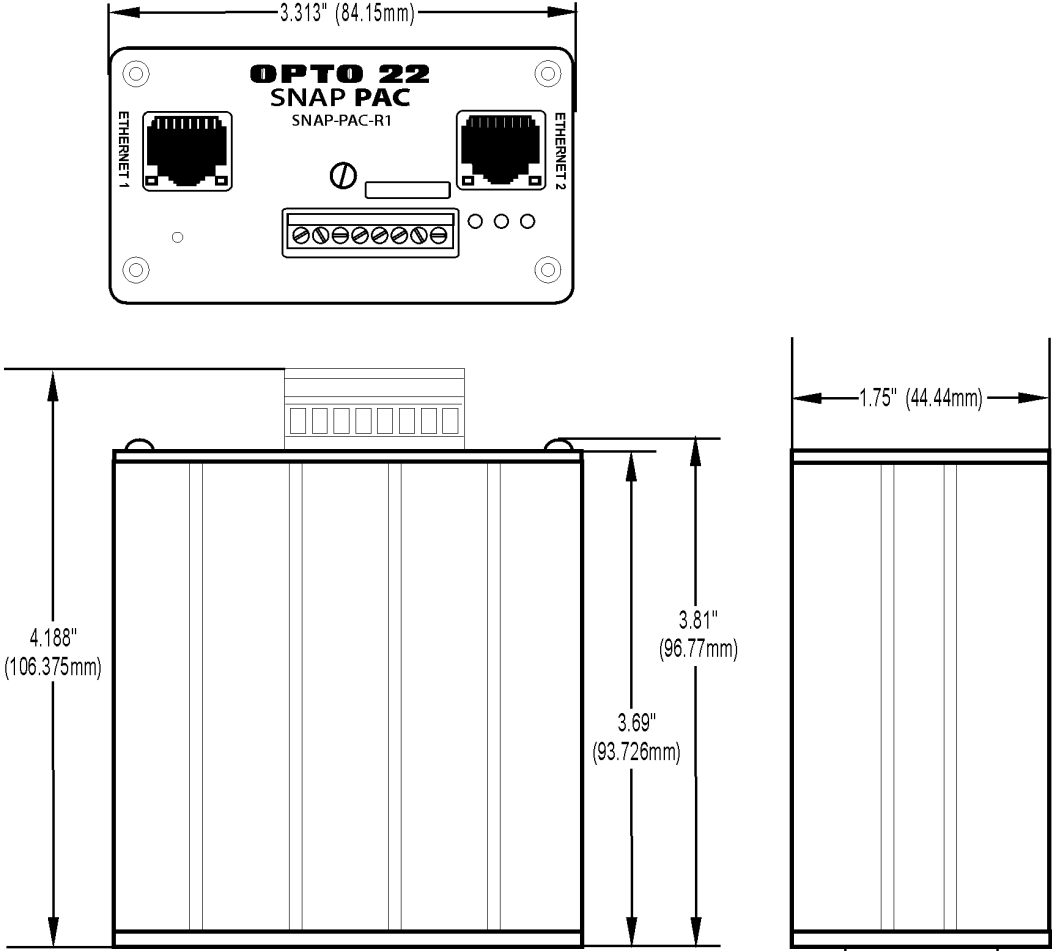

## INFORMATION ON FEATURES

All SNAP PAC R-series controllers offer many features, described in the following sections and summarized in the table on [page 33](#).

### Digital Point Features

To configure digital point features, see the *PAC Control User's Guide*. (Or *PAC Manager User's Guide*, if you are not using PAC Control. As noted below, some features require PAC Control.)

**Latches**—When the value of a digital input point changes from off to on, an on-latch is automatically set. While the value of the point may return to off, the on-latch remains set until cleared, as a record of the change. Similarly, an off-latch is set when the value of a digital point changes from on to off, and it remains set until cleared. Latching is automatic and needs no configuration.

**Watchdogs**—You can set a watchdog to monitor communication with the PC or other host device. If the host does not write data to the controller for the length of time set in the watchdog, the controller automatically sets digital and analog I/O points to values you have chosen. This action makes sure the process is brought to a safe state if communication fails.

**High-speed counters**—(R1 only) Any standard or high-density digital input can be used as a counter, counting the number of times the input changes from off to on. High-density digital points always act as counters without needing configuration. Standard digital points must be configured as counters; as soon as it is configured, the counter is automatically activated. The speed of the counter depends on the speed of the module.

**Quadrature counters**—(R1 only) When you configure points on a quadrature input module (SNAP-IDC5Q), the quadrature counter feature is automatically included. You can read the quadrature count from either point by reading the point's counter data.

**Additional digital features**—The following digital features are available when a SNAP PAC R-series controller is used with PAC Control. These features are not currently available through PAC Manager or the memory map. Use PAC Control commands to configure and access them. See the *PAC Control User's Guide* for more information.

- *TPO (time-proportional output)*—Time-proportional output varies the duty cycle and the percentage of on time within that cycle. TPO is often combined with a PID loop and used to control the output, for example in a heater or oven.
- *Pulse generation*—Includes continuous square waves, on-pulses, off-pulses, and N pulses. A pulse turns a digital output on (or off) briefly, either once or for a specified number of times at a specified interval. A digital square wave is a specific pattern of on and off states, repeated continuously.
- *Digital totalizing*—Tracks the total amount of time that a digital input point is on or the total amount of time it is off. Totalizing helps determine maintenance or use cycles.
- *On-pulse and off-pulse measurement*—(R1 only) A pulse is a brief on (or off) state, usually repeated at a specific interval. The controller can measure the first pulse, that is, the amount of time the input stays on (or stays off).
- *Frequency Measurement*—(R1 only) Frequency is the speed with which a digital point changes state. It's usually measured in counts per second. For example, reading the frequency can help you determine the speed of rotating machinery.
- *Period Measurement*—(R1 only) Period refers to the elapsed time for a complete on-off-on transition on a digital point. Measurement starts on the first transition (either off-to-on or on-to-off) and stops on the next transition of the same type.

## Analog Point Features

For information on configuring analog features, see the *PAC Control User's Guide* or, if you are not using PAC Control, the *PAC Manager User's Guide*.

**Watchdogs**—You can set a watchdog to monitor communication with the PC or other host device. If the host does not write data to the controller for the length of time set in the watchdog, the controller automatically sets designated I/O points to the values you have set. This action makes sure the process is brought to a safe state if communication fails.

**Scaling**—You can scale analog input or output points so that the values make sense for your situation. For example, you can scale a -5 V to +5 V input point to show 0% to 100%.

**Minimum and maximum values**—The controller automatically keeps track of minimum and maximum values. You can read these values at any time, for example, to record minimum and maximum temperatures. You can also reset min/max values. For example, if you want to record the maximum temperature at point 2 in each 24-hour period, you must reset the values after they are read each day.

**Offset and gain**—The controller can calculate offset and gain for analog input points. If a -50 mV to +50 mV input receives signals that are slightly off (not exactly -50 mV at the lowest point, for example), the offset and gain can be calculated so that values will appear accurately when read.

*NOTE: If you are using Modbus/TCP or EtherNet/IP, you will need to calculate the offset and gain yourself. Then you can write offset and gain values to the controller.*

**Output clamping**—The controller can clamp values sent to analog output points so they do not go above or below a specific limit. For example, if you are using a 0–10 VDC output module, but the device attached to one of its points can handle a maximum of only 5 VDC, you can set an upper clamp of 5 VDC for that point. The values for upper and lower clamp are set in engineering units.

**Average filter weight**—The controller can use a filter weight to smooth analog input signals that are erratic or change suddenly. See details in the *PAC Manager User's Guide*.

**Additional analog features**—The following analog features are available when a SNAP PAC R-series controller is used with PAC Control. These features are not currently available through PAC Manager or the memory map. Use PAC Control commands to configure and access them. See the *PAC Control User's Guide* for more information.

- *Ramping*—Some devices attached to analog outputs should not be abruptly stepped up or down, because a sudden change might damage the equipment or cause other problems. Instead, you can gradually ramp the device up or down to the desired value.
- *Analog totalizing*—For an analog input, a totalizer accumulates readings by sampling the input point at set intervals and storing the total value, for example to determine total flow based on a varying flow rate signal.

## Serial Communication

R-series PACs can communicate with serial devices either through the RS-232 connector on top of the controller (Port 0) or through SNAP serial communication modules on the rack.

The default configuration for Port 0 is communication with a host PC using a modem and PPP. To communicate with a serial device, first change Port 0's configuration in PAC Manager. Here are brief instructions; for more details, see "Configuring Direct Communication to Serial Devices" in the *PAC Manager User's Guide* (form 1704).

1. In PAC Manager's Inspect window, click Communications and choose Communication Port Control from the pop-up menu.
2. For Com Port 0, click PPP in the Control Function field and choose None from the list. Click Apply.
3. Save the configuration to flash memory.

Communication through the RS-232 port is handled through PAC Control commands. See “Communication Commands” in Chapter 10 of the *PAC Control User's Guide*.

For additional serial connections, use SNAP serial communication modules. Most serial modules provide two channels of serial data, typically to interface with printers, scales, chart recorders, RFID readers, or Wiegand® security devices. A Profibus® module provides one channel of data from Profibus DP devices. See the serial module's user's guide for details.

### PID Loops

Proportional integral derivative (PID) loops are used to drive a variable, often from an analog input, toward a desired value. The PID monitors the variable, compares it to the setpoint (the desired value) and calculates an output that will push the variable very close to the setpoint. Temperature control is a typical application for a PID.

Each SNAP PAC R-series controller can run up to 96 PID loops. PID loops run on the I/O side, independently from a PAC Control strategy. To use PID loops, configure them in PAC Control or PAC Manager, and use PAC Control tuning tools for ease in debugging. See the *PAC Control User's Guide* (form 1700) for more information.

### Additional Features

For information on configuring additional features available in the SNAP PAC R-series controller, including security and the use of protocols such as SNMP, SMTP, and FTP, see the *PAC Manager User's Guide*.



## SNAP-PAC-R1 AND -R2 COMPARISON CHART

The following table compares SNAP PAC R-series controllers with firmware 9.4 or newer.

FEATURE		SNAP-PAC-R1	SNAP-PAC-R1-FM	SNAP-PAC-R2	SNAP-PAC-R2-FM	SNAP-PAC-R1-B
Factory Mutual approval			●		●	●
UL approval		●	●	●	●	●
Digital I/O point features	Input latching	●	●	●	●	●
	On/off status	●	●	●	●	●
	Watchdog timer	●	●	●	●	●
	High-speed counting (up to 20 kHz) <sup>1</sup>	●	●			●
	Quadrature counting <sup>2</sup>	●	●			●
	On-pulse and off-pulse measurement <sup>1,3</sup>	●	●			●
	Frequency and Period measurement <sup>1,3</sup>	●	●			●
	TPO (time-proportional output) <sup>3</sup>	●	●	●	●	●
	Digital totalizing <sup>1,3</sup>	●	●	●	●	●
	Pulse generation (N pulses, continuous square wave, on-pulse, and off-pulse) <sup>3</sup>	●	●	●	●	●
Analog I/O point features	Thermocouple linearization (32-bit floating point for linearized values)	●	●	●	●	●
	Minimum/maximum values	●	●	●	●	●
	Offset and gain	●	●	●	●	●
	Scaling	●	●	●	●	●
	TPO (time-proportional output) <sup>4</sup>	●	●	●	●	●
	Output clamping	●	●	●	●	●
	Filter weight	●	●	●	●	●
	Watchdog timer	●	●	●	●	●
	Analog totalizing <sup>3</sup>	●	●	●	●	●
Ramping <sup>3</sup>	●	●	●	●	●	
High-density digital (HDD) modules (inputs and outputs)		●	●	●	●	●
Serial communication modules		●	●	●	●	●
PID logic (maximum 96 PID loops per controller)		●	●	●	●	●
Works with PAC Project software		●	●	●	●	●
Runs PAC Control strategies		●	●	●	●	●
Ethernet network (two independent network interfaces)		●	●	●	●	●
Security for Ethernet network (IP filtering, port access)		●	●	●	●	●
OPC driver support		●	●	●	●	●
Modbus/TCP (slave)		●	●	●	●	●
EtherNet/IP for communication with Allen-Bradley RSLogix PLCs		●	●	●	●	●
REST API (requires firmware R9.5a or higher)		●	●	●	●	●

SNAP-PAC-R1 AND -R2 COMPARISON CHART

FEATURE	SNAP-PAC-R1	SNAP-I-PAC-R1-FM	SNAP-PAC-R2	SNAP-I-PAC-R2-FM	SNAP-PAC-R1-B
HTTP/HTTPS (requires firmware R9.5a or higher)	●	●	●	●	●
OptoMMP memory-mapped protocol	●	●	●	●	●
SNMP (network management of I/O & variables)	●	●	●	●	●
PPP (dial-up and radio modems)	●	●	●	●	●
FTP server and client	●	●	●	●	●
Email (SMTP client)	●	●	●	●	●
UDP Streaming of I/O data to host	●	●	●	●	●
Serial port (RS-232)	●	●	●	●	●
Scratch Pad area—bits, floats, integers, strings	●	●	●	●	●
Digital events, alarm events, serial events	●	●	●	●	●
Event messages	●	●	●	●	●
Data logging in the controller	●	●	●	●	●
I/O point data mirroring and memory map copying	●	●	●	●	●
Realtime clock (RTC)	●	●	●	●	●
Mounting rack	SNAP PAC racks			B-series	
Number of modules per mounting rack	4, 8, 12, or 16			4, 8, 12, 16	
Module types and maximum numbers allowed per I/O unit (with largest rack)	16 digital (any type) 16 analog 8 serial			8 4-ch digital, 8 serial, 16 analog or HDD	

1 4-channel digital modules only; not available on high-density digital modules  
 2 Requires a SNAP quadrature input module (SNAP-IDC5Q)  
 3 Requires PAC Control Professional 8.2 or newer, or PAC Control Basic 9.0 or newer  
 4 Requires a SNAP analog TPO module (SNAP-AOD-29)

# 4: Maintenance and Troubleshooting

This chapter includes maintenance and troubleshooting information for SNAP PAC R-series controllers.

## In This Chapter

### Maintaining the SNAP PAC R-Series Controller:

Backup Battery .....	35
Changing the Controller's IP Address.....	35
Loading New Firmware .....	36
Setting Time and Date .....	36
Resetting the Controller.....	36
Using the MicroSD Card .....	37
Blink Codes.....	49

### Troubleshooting the SNAP PAC R-Series Controller:

Getting Device and Firmware Information.....	51
Communicating with the Controller.....	52
Additional Troubleshooting Tools.....	55
Troubleshooting I/O Modules: Frequently Asked Questions.....	56
SNAP Analog Troubleshooting.....	58

## MAINTAINING THE SNAP PAC R-SERIES CONTROLLER

### Backup Battery

The SNAP PAC R-series controller has a rechargeable battery that receives charging current whenever the controller has power. It will retain data for up to three years with the power off.

*NOTE: Models manufactured before July 1, 2007 have a user-replaceable 3-volt CR2032 Lithium battery (typical service life with power off: 5 years).*

### Changing the Controller's IP Address

**If you know the SNAP PAC R-series controller's IP address**, see the *PAC Manager User's Guide* for instructions to change it.

**If you do not know the IP address**, first check the label on the side of the controller. There are multiple labels, one for each Ethernet interface; the primary interface is labeled *Ethernet 1*. If you still don't know the controller's IP address, reset the controller to factory default settings following the instructions in "[Resetting the Controller](#)," below, and then set the IP address as described in the *PAC Manager User's Guide*.

### Loading New Firmware

Each SNAP PAC R-series controller contains firmware (sometimes referred to as the *kernel*), which is similar to an operating system. If the firmware should become damaged, or if a new version of the firmware is released, you can load new firmware to the controller following instructions in the *PAC Manager User's Guide*.

You can also load firmware using a microSD card (on R-series PACs that have a microSD card slot). See [“Using the microSD Card” on page 37](#) for details.

**CAUTION:** Loading new firmware deletes your PAC Control strategy (even if stored to flash memory) and your persistent variables. Make sure you have **archived** your strategy before loading new firmware.

### Setting Time and Date

The SNAP PAC R-series controller's built-in clock is set at the factory. To change the time and date, see the instructions in the *PAC Manager User's Guide*.

### Resetting the Controller

1. Carefully insert a straightened paperclip or stiff wire into the small hole labeled RESET.
2. Depending on the type of reset you need, press and hold down the RESET button as described below. DO NOT hold the button down too long.

*NOTE: Do not reset the brain to hardware test mode unless Opto 22 Product Support tells you to.*

Reset type	How to use the reset button	What happens	Notes
Simple reset	Press and release immediately	Controller restarts. Any files and the strategy are erased unless they have been stored to flash memory. Archived strategies are not erased.	
Restore factory defaults	Press just until STAT LED turns solid green (1-2 sec)	Controller restarts. <b>If a microSD card is present</b> and contains configuration, firmware, and/or strategy files—Files on the microSD card overwrite what is in flash memory and other files in flash memory are not erased. Data files on the card are not affected.* <b>If no microSD card is present</b> containing configuration, firmware, or strategy files—All files, strategy, archived strategy, persistent variables, and I/O configuration are erased from RAM and flash memory, and IP addresses are reset to 0.0.0.0 and subnet masks to 255.255.255.0.	If no microSD card is present containing configuration, firmware, or strategy files, you must reassign the IP address and subnet mask.
Failsafe bootloader mode	Press and wait while LED turns solid green. Release when LED starts to blink (2-5 sec)	Controller restarts. Any files and the strategy are erased unless they have been stored to flash memory. Archived strategies are not erased.	Cycle power to recover. Result is the same as a simple reset.
Hardware test mode	Press and hold until LED starts blinking orange rapidly and continuously (> 5 sec)	Controller restarts. Any files, strategy, archived strategy, and persistent variables in RAM and flash memory are erased. I/O configuration in flash is erased (R-series). Data files on a microSD card are not affected. IP addresses are reset to 0.0.0.0 and subnet masks to 255.255.255.0.	To recover, restore to factory defaults as described above. You also must reassign the IP address and subnet mask.

\* Example of Restoring factory defaults when a microSD card is present: Suppose the card contains a firmware file but no configuration or strategy files. Restoring to factory defaults will leave the controller with the firmware from the card and configuration and strategy files from flash memory. You will not have to reassign an IP address or download a strategy.

## Using the microSD Card

SNAP PAC controllers with a manufacturing date code of 11/08 (November 2008) and newer have a microSD card slot in the top of the controller's case. On a controller with a microSD card slot, the STAT LED blinks briefly about once every five seconds, indicating that the controller is checking to see if a card is in place.



**IMPORTANT:** *Since the first release, card behavior has changed. If you are using firmware older than R9.0a, follow the instructions in [Using microSD with Older Controller Firmware Technical Note \(form 2018\)](#) instead of this document.*

To determine firmware version, see [page 40](#). To download the latest firmware (recommended), go to [www.opto22.com/site/downloads](http://www.opto22.com/site/downloads) and filter by Firmware.

### Card Type and Format

Use only cards with the microSD or microSDHC logos (shown above right). Also, be aware that card capacity, formatting, and filename limits vary depending on your controller, its firmware and loader, and the card type you are using:

Controller firmware	Compatible cards	Card format	Max card capacity	Filename limits
Firmware 9.4a or higher and loader 6.1a or higher	microSDHC	FAT32	32 GB	Long names OK
	microSD	FAT32 or FAT16	2 GB	Long names OK
R9.0a to R9.3e	microSD	FAT16	2 GB	8 dot 3*
Lower than R9.0**	microSD	FAT16	2 GB	8 dot 3*

\* All files stored on the microSD card must be named with a maximum of eight characters in the name plus three characters in the extension (8 dot 3 format), for example: datafile.txt

\*\* The card behaves differently using firmware lower than R9.0. Follow the instructions in [Using microSD with Older Controller Firmware Technical Note \(form 2018\)](#) instead of this document.

**IMPORTANT:** *Minimum controller firmware version R9.4a and loader version R6.1a are required to use microSDHC cards. For more information, see [OptoKnowledgeBase article KB83929](#).*

### MicroSD/SDHC Card Uses

Note minimum requirements in the table above. The card can be used for several purposes:

- To store data or files, which you can access using PAC Control commands or an FTP client. (PAC Manager cannot be used to access data, because it cannot see the card's directory.)
- To quickly commission a replacement controller in the unlikely event that a controller fails.
- To update firmware on the controller or on a serial communication module on the controller's rack. The card provides a convenient way to update firmware on non-networked controllers. It's also useful if PAC Manager is not available to update firmware.
- To temporarily boot the controller from firmware on the microSD card rather than from the firmware in the controller, for example to test new firmware.
- To update, run, or test new PAC Control strategies if the controller is not on the network, if PAC Control isn't available, or if you want to test a new strategy without erasing the existing one.

The following table summarizes how to use the card; see the page in the last column for steps.

To do this	When	Put card in...	Use this method	See pg
Store/access data	Anytime	Controller	Automate data storage and retrieval in PAC Control logic: Use PAC Control commands and file communication handles. Or use PAC Control FTP communication handles.	39
		Controller <sup>1</sup>	From a PC, use an FTP client.	
		PC with card reader	Use Windows Explorer.	
Replace failed controller using a prepared card	In advance	Controller <sup>1</sup>	1. Use PAC Manager Inspect window to store IP address and configuration data to card. 2. Use PAC Control to make controller download (.cdf) file. 3. Create a command file to load firmware. 4. Copy .cdf file, command file, and firmware file to card.	41
		PC with card reader		
Try out controller firmware without replacing current firmware	In advance	Controller <sup>1</sup> or PC with card reader	Use Windows Explorer or FTP client to copy new firmware to card.	45
		To use	Controller	
Try out new strategy without replacing current strategy <sup>4</sup>	In advance	Controller <sup>1</sup> or PC with card reader	Use PAC Control to make controller download (.cdf) file; then use Windows Explorer or FTP client to put .cdf file on the card.	47
		To use	Controller	
Update non-networked controller with new firmware <sup>4</sup>	In advance	PC with card reader	Create command file; copy it and the firmware file to card.	44
		To use	Controller	
Update non-networked controller with new strategy <sup>4</sup>	In advance	PC with card reader	Use PAC Control to make controller download (.cdf) file; then use Windows Explorer to copy .cdf file to the card.	47
		To use	Controller	

1 Controller must be on same network segment as PC.  
 2 CAUTION: Before resetting, make sure you know what is on the card! ALL IP address and configuration information, firmware, and strategy that exist on the card are saved to flash memory.  
 3 If you have firmware R9.x but a loader older than 6.x, the controller runs the new strategy from card until reset, but the strategy cannot be saved to flash memory.  
 4 CAUTION: Persistent variables will be deleted.

### Storing and Accessing Data or Files

When inserted into the controller and accessed from a PC using FTP or PAC Control, the card appears as a directory in the controller's file system named: `sdcard0`. Just like a PC might show a thumb drive as a directory named Removable Disk (E:), for example, the controller shows the card as a directory named `sdcard0`.

**IMPORTANT:** Do NOT try to create this directory. When you look at the card in the controller, the card appears as a directory named `sdcard0`. When you look at the card in a card reader attached to your PC, you see the card reader's directory instead. When the card is in a card reader, you are already in the root of the card (that is, you are already inside the `sdcard0` directory).

For example, suppose you are looking at a card in a SNAP PAC controller with IP address 10.192.54.241. You can see that this controller has three files in its regular file system, plus the card:

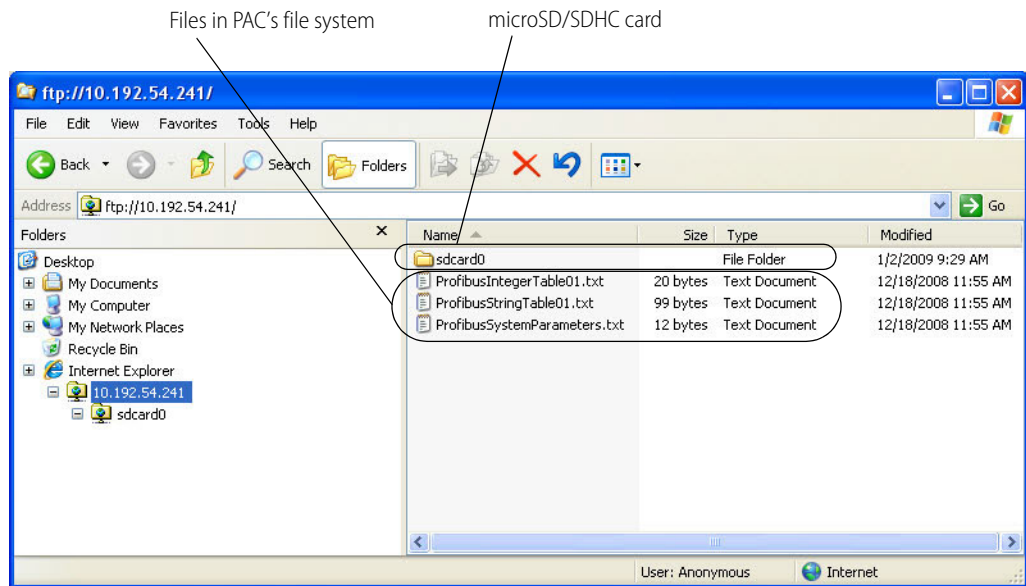

Within the `sdcard0` directory on the controller (or the root if the card is in a card reader), you can create other directories and create or add files. For a card formatted with FAT16, you can have up to 512 files or directories in the root directory, and each subdirectory can have up to 65,534 files. Cards formatted with FAT32 have no restrictions on the number of files in the root. Note filename requirements in [“Card Type and Format” on page 37](#).

When the card is in the controller, you can access files on the card through PAC Control commands and from a PC using FTP.

**Use PAC Control commands** just as you would with any other file in the controller's file system. For help, see “Using the Control Engine's File System” in the [PAC Control User's Guide](#) (form 1700). Remember to include the card's directory name in the path in the file communication handle, for example:

```
file:a,/sdcard0/VoltLog.txt
```

Note that the path separator is a forward slash (/), not a backward slash (\).

You can also use the FTP communication handle in PAC Control to manipulate files. See the section “Moving Files via FTP,” also in the [PAC Control User's Guide](#).

**To move files to or from a PC**, use any standard FTP software. (Don't use PAC Manager as the FTP client, as it cannot see directories within the controller's file system). Remember to include the card's directory name, for example: `ftp://192.168.1.1/sdcard0/`

*NOTE: If you access the card when it is not in the controller (for example, in a card reader), the sdcard0 directory does not appear. Do NOT create it. The controller treats the card as a folder in the controller's file system.*

### Displaying Free Space on the Card

If you need to know how many free bytes are left on a microSD/SDHC card, you can use PAC Control or PAC Manager to read this data from an address in the controller's memory map. In a PAC Control strategy, for example, you could notify an operator if the card needs replacing, based on the number of bytes still unused.

1. Make sure the card is in the controller.
2. In PAC Control, use the command Read Number from I/O Unit Memory Map to read memory map address F7002204. Use Integer 32 Variable in Argument 2.

For more information, see "I/O Unit—Memory Map Commands" in the *PAC Control User's Guide*, and see "Read Number from I/O Unit Memory Map" in the *PAC Control Command Reference* (form 1701).

3. In PAC Manager, open the Inspect window for the controller. Click Other and choose Generic Read/Write from the popup menu. In the Address field, type F7002204. From the Type list, choose 32-bit Integer. Leave the Length as 1. Click Refresh.

The number of bytes appears in the Value column.

### Checking Firmware and Loader Versions

Compatible cards and card functions depend on the controller's firmware and loader versions. Here's how to check them. The controller must be on the same network segment as the PC with PAC Manager.

1. Open PAC Manager and click the Inspect icon .
2. In the Device Name field, enter the controller's name or IP address, or choose it from the drop-down list. Click Status Read.

Loader and firmware version numbers appear near the center of the window:

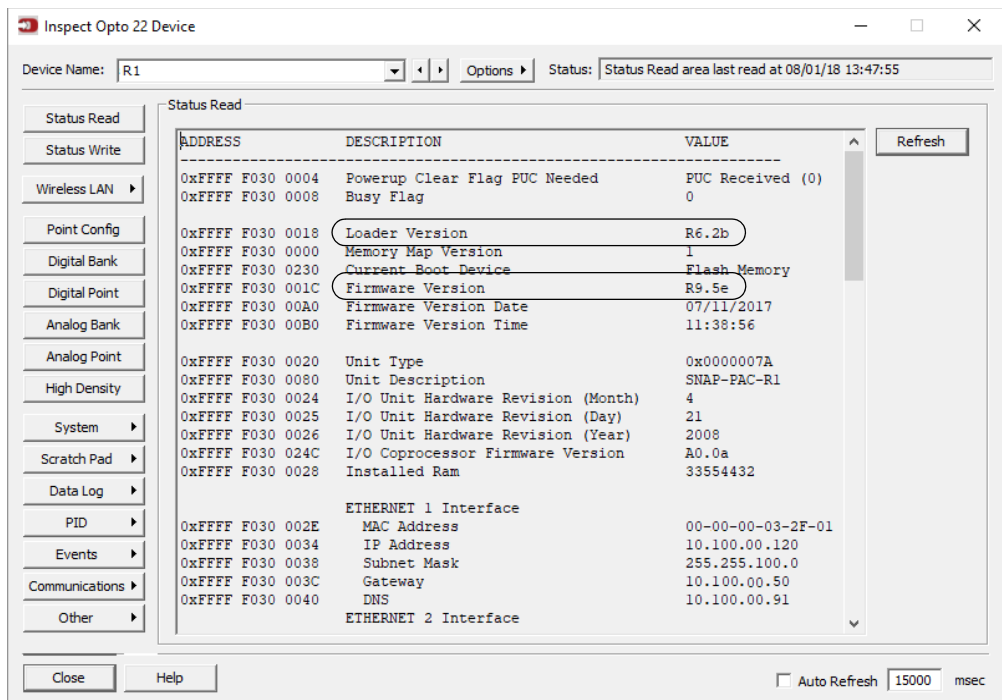

New firmware versions and some new loader versions are available from our website, [www.opto22.com](http://www.opto22.com). To update the loader, see [Updating the Loader on a SNAP Device](#) (form 1789). For firmware, see "Loading New Firmware" on page 36. Contact Opto 22 Product Support with any questions.



### Replacing a Controller

A microSD/SDHC card can be used to quickly commission a replacement controller in the unlikely event that an existing controller fails. The card rapidly configures the replacement with the original controller's IP address, firmware, configuration, and strategy.

*Preparing the card* requires PAC Manager R9.0 or higher. You must prepare the card in advance and then keep it in a safe place in case the controller fails.

The *replacement controller* must have exactly the same part number as the old controller (for example, a SNAP-PAC-S1-W must be replaced by a SNAP-PAC-S1-W), and it must have minimum firmware R9.0a and loader 6.0a. See [page 40](#) to check versions.

**CAUTION:** Use the commissioning card only to replace a controller; it assigns the new PAC controller the same IP address as the old one.

### Prepare the Card In Advance.

1. Put a blank card into the controller that you may need to replace.
2. Copy configuration data as follows:
  - a. Open PAC Manager if needed. In the main window, click the Inspect icon .
  - b. In the Device Name field, type the name (or IP address) of the device. Click Status Write.
  - c. In the Operation Command list, highlight Store configuration and IP settings to microSD.

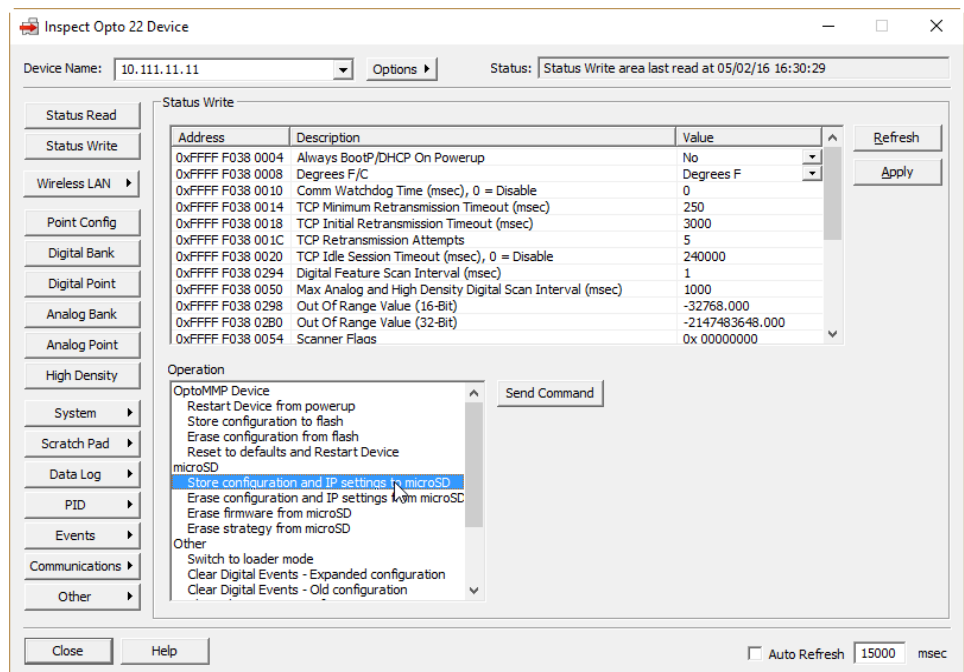

- d. Click Send Command.

The controller's IP settings and all configuration data are saved to the card in a file located at `/sdcard0/opto22/config/config.cfg`.

3. Prepare the strategy file:
  - a. Open your strategy in PAC Control. In Configure mode, choose File > Strategy Options. Click the Download tab.

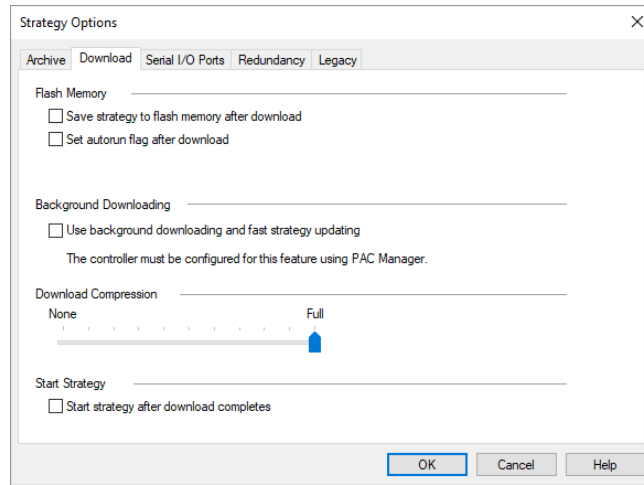

- b. Check the Set autorun flag after download box. Click OK.
- c. Choose one of the following:
  - If you’re using PAC Terminal Secure Strategy Distribution (SSD), follow the steps in *PAC Terminal SSD Technical Note* (form 1762, available with purchase of [PAC Terminal SSD](#)) to create a download file with the file extension .ssd.
  - Otherwise, compile the strategy as a Control Engine Download file (.cdf) by right-clicking the name of the control engine in the Strategy Tree and choosing Compile Control Engine Download File from the pop-up menu.

The file is created in the same folder as the strategy, with a .cdf extension and a filename consisting of the strategy’s name and the control engine’s name (for example, MyStrategy.MyEngine.cdf).
- d. (Firmware below R9.4a only): Rename the .cdf or .ssd strategy file to fit the 8 dot 3 filename format for the microSD card (see [“Card Type and Format” on page 37](#)).

**IMPORTANT:** You must retain the correct file extension (.cdf or .ssd).

4. Remove the card from the controller and put it in a card reader attached to the PC. Prepare the firmware file:
  - a. Locate the firmware file you want to upgrade to.
  - b. (Firmware below R9.4a only): Rename the file to fit the 8 dot 3 filename format.  
For this file, do not keep the same file extension. Recommended naming scheme: PPP-TMM.mmb where:

PPP = controller type (R1, R2)  
 T = R for release (or B for beta)  
 MM = major revision number  
 mm = minor revision number  
 b = build letter

Example of an original firmware filename: `snap-pac-r2-R9.0a.bin`

Example of the same firmware file, renamed: `R2-R9.0a`

5. Create the firmware command file:
  - a. Using Notepad or a similar editor, create a text file named: `command`  
In the `command` file, type the following command (CASE SENSITIVE):  
`Krn <file>`  
`<file>` is the firmware path and filename as the card sees it, so do not include the `sdcard0` directory in the path. If you're using Secure Strategy Distribution, `<file>` must include a valid signature. Here is a sample command file:

```
Krn R2-R9.0a
```

- b. In Windows Explorer, delete the `.txt` extension from the command file. Then right-click the command file filename and choose Properties. In the General tab, click to put a checkmark in the Read-only box. Click OK.
6. Copy files to the card:
  - a. Copy the command file to the `sdcard0` directory in the controller's file system.
  - b. Copy the firmware file to the `sdcard0` directory. This directory must contain only one firmware file.
  - c. In the `sdcard0` directory on the card, create a new directory and name it: `strategy`  
Copy the renamed strategy file (`.cdf` or `.ssd`) to the `sdcard0/strategy` directory.

The card is now ready to be used as a commissioning card to replace the controller.

### Replacing the Failed Controller.

Before you start, make sure that the replacement controller:

- Has *exactly the same part number* as the old controller (for example, a SNAP-PAC-S1-W must be replaced by a SNAP-PAC-S1-W)
- Has *minimum firmware R9.0a and minimum loader R6.0a*. To check firmware and loader versions in PAC Manager, see [page 40](#). You can download new firmware from our website; if you need a newer loader, contact Product Support.

Follow these steps to replace the failed controller:

7. Turn off the controller that failed. Put the new controller in its place but DO NOT apply power. Attach network cables.
8. Insert the prepared microSD/SDHC card and turn on power to the controller.
9. Without waiting, carefully insert a straightened paperclip or stiff wire into the small hole on the controller labeled RESET. Press and hold the Reset button just until the STAT LED turns solid green, and then immediately release the button.

The IP address is assigned to the controller, and firmware, configuration data, and strategy are loaded into RAM, in that order.

- In firmware R9.2c and newer, IP address, firmware, configuration, and strategy are stored to flash and the controller reboots running the new firmware. The STAT LED blinks steadily during this process and then blinks two sets of three blinks—green to indicate success, or red to indicate failure.
- In firmware R9.0–R9.2b, IP address, firmware and configuration are stored to flash and the controller reboots running the new firmware and loads the new strategy. To store the strategy to flash, use the Reset button again in exactly the same way.

When finished, a folder named `backup` is placed in the root directory of the card. The controller restarts.

10. Wait until the STAT LED blinks only once every five seconds, and then remove the card.

### Updating Firmware

The card can also be used to update firmware if the controller is not on the network, or if PAC Manager isn't available. The card can update both controller firmware and serial communication module firmware.

**CAUTION:** Before updating firmware, make sure you know what is on the card! Any IP address, configuration data, and strategy on the card will be saved to flash memory along with the firmware. If you want only the firmware saved, delete configuration and strategy files from the card.

**CAUTION:** Updating firmware deletes your PAC Control strategy (even if stored to flash memory) and your persistent variables. Make sure you have **archived** your strategy before loading new firmware.

1. Obtain the correct firmware file from our website, [www.opto22.com](http://www.opto22.com). If you are using Secure Strategy Distribution (SSD), the firmware must have the correct signature.
2. (Firmware below R9.4a only): Rename the firmware file to fit the 8 dot 3 filename format (see "Card Type and Format" on page 37).

The original file extension does not have to be retained. To make sure the file is clearly identified, we recommend a name such as the following: `PPP-TMM.mmb` where:

PPP = controller type (R1, R2)  
 T = R for release (or B for beta)  
 MM = major revision number  
 mm = minor revision number  
 b = build letter

Example of an original firmware filename: `snap-pac-r2-R9.0a.bin`

Example of the same firmware file, renamed: `R2-R9.0a`

3. Copy the firmware file to a blank card. If you don't have a blank card, delete the following directories and their contents if they appear on the card:

```
/sdcard0/strategy
/sdcard0/boot
/sdcard0/opto22/config
```

You can write to the card in one of two ways: either use your PC to FTP files to the card in the controller, or use a card reader with your PC and simply copy files with Windows Explorer.

4. Using Notepad or a similar text editor, create a command file named `command.txt` and save it in the root directory of the card. (If you are looking at the card in a card reader, save it in the root directory. If you are looking at the card in the controller, save it in the directory named `sdcard0`).
5. In the `command` file, include the following commands as needed, all in the same file. All commands are CASE SENSITIVE.

To do this	Use command	Details
Install serial communication module firmware	<code>ModKrn &lt;file&gt;, &lt;modpos&gt;</code>	<p>&lt;file&gt; is the firmware path and file as the card sees it, so do not include <code>sdcard0</code> directory in the path. The firmware file can be compressed in gzip format or uncompressed. * &lt;modpos&gt; is the position of the module on the rack.</p> <p><b>NOTE:</b> If this file exists, it will be installed. Firmware checking is impossible on serial modules.</p> <p><b>CAUTION:</b> Installing the wrong firmware on a serial module will make the module unusable. Make sure you have the correct firmware!</p>

To do this	Use command	Details
Install controller firmware	<code>Krn &lt;file&gt;</code>	<p>&lt;file&gt; is the firmware path and filename as the card sees it, so do not include <code>sdcard0</code> directory in the path. The firmware file can be compressed in gzip format or uncompressed.* If you're using Secure Strategy Distribution, &lt;file&gt; must include a valid signature.</p> <p><b>NOTE:</b> If installing both module and controller firmware, make sure the <code>ModKrn</code> command comes before the <code>Krn</code> command, as <code>Krn</code> resets the controller.</p> <p><b>NOTE:</b> Controller firmware will be installed only if it differs from the current firmware.</p>

\* To gzip a file on Windows, use the utility at <http://gnuwin32.sourceforge.net/packages/gzip.htm>. SNAP PAC cannot decompress files that were compressed with WinZip

The following sample command file updates firmware on the controller.

```
Krn R2-R9.0a
```

The following sample command file updates firmware on the controller and on two serial modules. The update commands for the serial modules must be listed first. This file updates version R2.0a on an RS-232 serial module in slot 3, firmware version R1.3c on a motion control module (a special type of serial module) in slot 6, and firmware version R9.4a on a SNAP-PAC-R2 controller. Note that the motion control firmware is located in a directory named `motion`. It doesn't have to be in its own directory; module and controller firmware files can be in the same directory or in separate directories, as you choose. If you show a path in the command file, note that you must use a forward slash (/), not a backward slash (\).

```
ModKrn SCM-R2.0a, 3
ModKrn motion/MOT-R1.3c, 6
Krn R2-R9.4a
```

- In Windows Explorer, delete the `.txt` file extension from the file so that the complete filename is only: `command`. Then right-click the command file and choose Properties. In the General tab, click to put a check in the Read-only box. Click OK.

**CAUTION:** Make sure you know what is on the card before updating firmware! Any IP address, configuration, or strategy data that exists on the card will also be saved to flash memory along with the firmware.

- To update firmware, insert the card in the controller's card slot. Carefully insert a straightened paper clip or stiff wire into the small hole on the controller labeled RESET. Press and hold the Reset button just until the STAT LED turns solid green, and then immediately release the button.  
Firmware is updated and saved to flash memory. (If IP address, configuration, or strategy files are on the card, they are also saved to flash memory.) When finished, a file named `response` is placed in the root directory of the card; this file indicates the success or failure of commands in the command file. Then the controller restarts.
- Wait until the STAT LED blinks only once every five seconds, and then remove the card.

### Booting from Firmware on the Card

You can also boot the controller from firmware on the card, rather than from the firmware in flash memory, for example to test new firmware before updating it on the controller.

You can write to the card in one of two ways: either use your PC to FTP files to the card in the controller, or use a card reader with your PC and simply copy files with Windows Explorer.

**NOTE:** Controllers configured for Secure Strategy Distribution (SSD) cannot boot from the card.

1. Locate the firmware file you wish to boot from.
2. (Firmware below R9.4a only): Rename the file to fit the 8 dot 3 filename format (see “Card Type and Format” on page 37).

Recommended naming scheme: PPP-TMM.mmb where:

PPP = controller type (R1, R2)  
 T = R for release (or B for beta)  
 MM = major revision number  
 mm = minor revision number  
 b = build letter

Example of an original firmware filename: snap-pac-r2-R9.0a.bin

Example of the same firmware file, renamed: R2-R9.0a

3. Create a directory on the card in the root and name it: boot  
 Remember, if you are looking at the card *in the controller*, you create the boot directory in the sdcard0 directory. If you are looking at the card *in a card reader*, create the boot directory at the top level. The controller’s file system treats the card as a directory named sdcard0.
4. Copy the renamed firmware file to the sdcard0/boot directory on the card.  
 Here’s how it might appear if you are looking at the card in the controller:

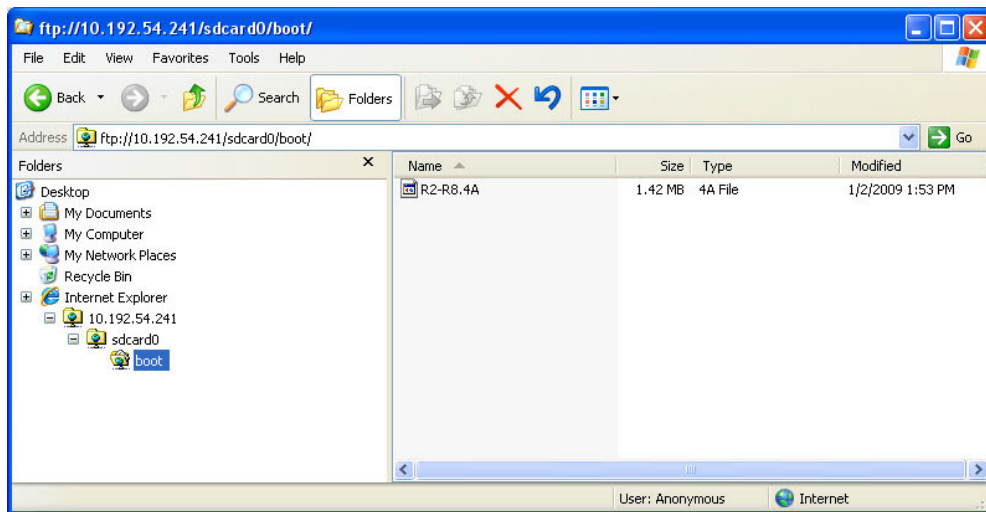

**IMPORTANT:** The boot directory must contain only one firmware file. If it contains more than one, the wrong firmware may be loaded.

5. If the card contains a command file or any other firmware files, delete them.
6. To boot the controller from firmware on the card, turn the controller off and insert the card in the controller’s card slot. Turn the controller back on. (Or insert the card and then quickly push and release the controller’s Reset button.)  
 If the boot directory exists on the card, the STAT LED blinks green three times, quickly. Firmware is loaded. If the STAT LED blinks red, see “Blink Codes” in this chapter to determine the problem.  
 If the STAT LED blinks green two times, either the boot directory is not present, the firmware file is invalid or does not match the controller, or the controller is an SSD controller.  
 When the STAT LED no longer blinks steadily, but blinks only once every five seconds, you can remove the card. When the card is removed, the controller continues running the firmware on the card until power is cycled or the controller is reset. If you need to know whether the controller booted from the card or from

flash memory, use PAC Manager's Inspect window to check the Status Read area. See the [PAC Manager User's Guide](#) for instructions.

### Updating, Running, or Testing a Strategy

The card can also be used to update, run, or test a PAC Control strategy. This ability is useful when the controller is not on the network or PAC Control isn't available. Both regular strategies and Secure Strategy Distribution (SSD) strategies can be used.

You can write to the card in one of two ways: either use your PC to FTP files to the card in the controller, or use a card reader with your PC and copy files with Windows Explorer.

**CAUTION:** Before saving to flash memory, make sure you know what is on the card! ALL IP address, configuration data, and firmware on the card will be saved to flash along with the strategy. If you want only the strategy saved, delete configuration and firmware files from the card.

1. In PAC Control Configure mode, choose File > Strategy Options. Click the Download tab.

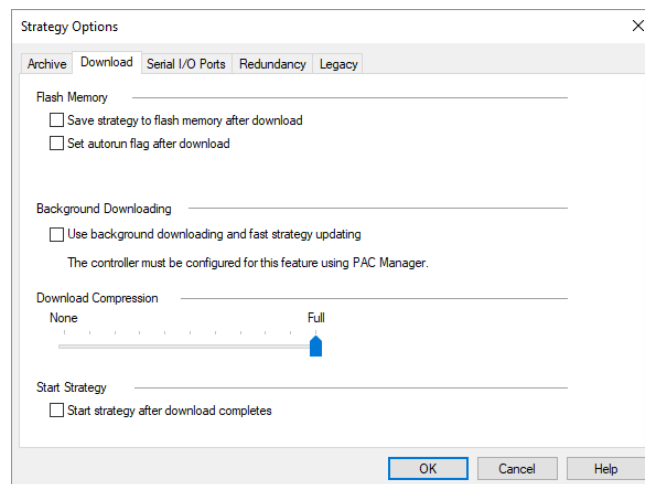

2. If you want to set the strategy to autorun, check the box Set autorun flag after download.
 

Autorun works if you insert the card and then turn on the controller; it has no effect if you insert the card when the controller is already turned on. (If the controller is already turned on, the new strategy follows the status of the existing strategy: if the existing strategy was running when the card was inserted, the new strategy will run; otherwise, it will not.)

If you use background downloading, the controller will switch to the new strategy when the card is inserted.
3. Click OK.
4. Choose one of the following:
  - a. If you're using PAC Terminal Secure Strategy Distribution (SSD), follow the steps in *PAC Terminal SSD Technical Note* (form 1762, available with purchase of [PAC Terminal SSD](#)) to create a download file with the file extension .ssd.
  - b. Otherwise, compile the strategy as a Control Engine Download file (.cdf) by right-clicking the name of the control engine in the Strategy Tree and choosing Compile Control Engine Download File from the pop-up menu.
 

The file is created in the same folder as the strategy, with a .cdf extension and a filename consisting of the strategy's name and the control engine's name (for example, MyStrategy.MyEngine.cdf).
5. (Firmware below R9.4a only): Rename the .cdf or .ssd strategy file to fit the 8 dot 3 filename format for the microSD card (see ["Card Type and Format" on page 37](#)).

**IMPORTANT:** You must retain the correct file extension (.cdf or .ssd).

6. Create a directory on the card in the root and name it: `strategy`  
Remember, if you are looking at the card *in the controller*, you create the `strategy` directory in the `sdcard0` directory. If you are looking at the card *in a card reader*, create the `strategy` directory at the top level. The controller's file system treats the card as a directory named `sdcard0`.
7. Copy the renamed strategy file to the `sdcard0/strategy` directory on the microSD card.  
Here's an example of a strategy file in the strategy directory, looking at the card in the controller:

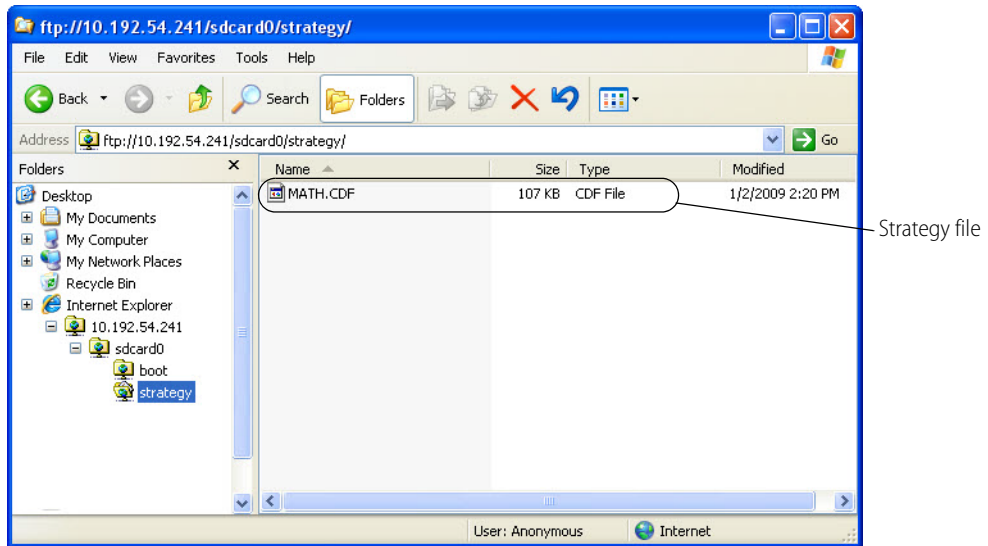

8. If you plan to save the strategy to flash memory, delete the following files and directories if they are on the card:

Command file and firmware files  
`/sdcard0/boot`  
`/sdcard0/opto22/config`

*NOTE: If the controller has firmware R9.0a or newer and a loader version older than R6.0a, you cannot save the strategy from the card to flash memory.*

9. To update, run, or test the strategy, turn off the controller, put the card in, and turn the controller back on. The controller loads the strategy from the card (verifying the signature if it is an .ssd file), switches to the new strategy if you're using background downloading, and runs the new strategy if you set it to `autorun`. If it's not set to `autorun`, you can start the strategy manually using PAC Control or PAC Terminal.  
The STAT LED blinks steadily while the strategy is loading and then blinks two sets of three blinks—green to indicate success, or red to indicate failure. When the STAT LED no longer blinks steadily, but blinks only once every five seconds, it has finished.
10. If you want to save the strategy to flash memory, carefully insert a straightened paperclip or stiff wire into the small hole on the controller labeled `RESET`. Press and hold the Reset button just until the STAT LED turns solid green, and then immediately release the button.  
The strategy is saved to flash memory. (If IP address, configuration, or firmware files are on the card, they are also saved to flash memory.) Then the controller restarts.
11. Wait until the STAT LED blinks only once every five seconds, and then remove the card.



### Disabling or Enabling Firmware and Strategy Updates Via the Card

If you do not want anyone to be able to update firmware or strategies using a microSD/SDHC card, you can disable this feature in the controller. (Enabled is the default.)

1. In PAC Manager, open the Inspect window for the controller.
2. Click Other and choose Generic Read/Write from the popup menu.
3. In the Address field, type F7002200. Choose 32-bit Integer as the Type.
4. To disable firmware/strategy updates: In the Value column next to the address, type 0 (zero). Click Apply.
5. To enable firmware/strategy updates: In the Value column, type any value other than zero and click Apply.

### Blink Codes

See [“Connectors and LEDs” on page 28](#) for the location of LEDs.

#### STAT LED

The STAT LED on the top of the SNAP PAC R-series controller uses blink codes to indicate controller operation and status conditions. The blink codes can be useful during normal operation and when troubleshooting.

- When the STAT LED steadily glows green it indicates that one or more flowcharts are running.
- When the STAT LED steadily glows orange, it means the controller is on, and either:
  - There isn't any strategy in the controller, or
  - The strategy in the controller is stopped, or
  - The strategy in the controller has run, and no flowcharts are currently running.

If your R-series PAC has a microSD card slot, the STAT LED:

- Briefly blinks off once every five seconds when it checks to see if a card has been inserted into the card slot.
- Rapidly blinks when it is reading or writing to the card.

For more information on microSD, see [“Using the MicroSD Card” on page 37](#).

**If the STAT LED blinks green when the controller starts up**, it indicates the following:

Number of Blinks	Speed of Blinks	Means
2	fast	Loading firmware from Flash memory to SDRAM.
5	fast	Default settings have been successfully restored.
7	fast	(Loader versions 5.1b and older) Entering fail-safe boot-loader mode. (See <a href="#">“Resetting the Controller” on page 36</a> .)

**If the STAT LED is blinking orange**, it indicates the following:

Number of Blinks	Speed of Blinks	Means
(continuous)	slow*	There is a problem with the bootloader. Contact Product Support.
(continuous)	fast	No IP address is assigned to the controller. This may also indicate that the controller is in hardware test mode.

\* About once per second

If the STAT LED blinks red and green alternately, it indicates the following:

Number of Blinks	Speed of Blinks	Means
(continuous)	fast	(Loader versions 5.1c and newer) Entering fail-safe boot-loader mode. (See <a href="#">“Resetting the Controller” on page 36.</a> )

If the STAT LED is blinking red, it indicates the following:

Number of Blinks	Speed of Blinks	Means	Problem and Workaround
2	slow	Flash programming failure	Flash chips were not erased properly or programmed properly. Contact Product Support.
3	slow	Firmware CRC check failed.	The firmware in the device is damaged. See Replacing Damaged Firmware in chapter 6 of the <a href="#">PAC Manager User’s Guide</a> (form 1704).
4	slow	Invalid MAC address or hardware revision	Contact Product Support.
5	slow	Fatal error	Firmware or hardware problem. Check the power supply and connections before restarting. Call Product Support if the error is repeated.
6	slow	RAM error	Contact Product Support.
7	slow	Loader problem	Firmware or hardware problem. Confirm Ethernet cables are connected. Try turning off power to the controller and turning it back on again. Call Product Support if the error is repeated.
11	slow	Firmware failed to initialize communications on ETHERNET 1.	Contact Product Support.
12	slow	Firmware failed to initialize communications on ETHERNET 2.	Contact Product Support.
13	slow	Real-time clock failure	Contact Product Support.

**PPP LED**

The programmable PPP LED must be set to PPP (the default) in order to indicate the current state of a PPP connection. For more information on programming the PPP LED, see the [PAC Manager User’s Guide](#) (form 1704) or the [OptoMMP Protocol Guide](#), (form 1465).

The PPP LED blink codes are as follows:

Color of LED	Speed of Blinks	Means
Green	Solid	There is a PPP connection.
Green	Slow	A PPP connection is being established.
Orange	Solid	The controller is listening on its PPP port.
Orange	Slow	PPP is disconnecting. After disconnecting, if Incoming PPP is enabled in PAC Manager, PPP listens for incoming calls. Otherwise, PPP enters Idle state (from which it can initiate an outgoing call). To configure PPP, see the <a href="#">PAC Manager User’s Guide</a> .
Red	Slow	The PPP service has been instructed to stop and is shutting down.
Off	n/a	The PPP connection is idle or disabled.

232 LED

The 232 LED indicates the following:

Color of LED	Means
Green	The controller is transmitting data.
Red	The controller is receiving data.
Orange	The controller is transmitting and receiving data simultaneously.

## TRUBLESHOOTING THE SNAP PAC R-SERIES CONTROLLER

If you encounter a problem while installing or using the SNAP PAC R-series controller, check the information in this section. If you need to contact Opto 22 Product Support, see “For Help” on page 5.

### Getting Device and Firmware Information

If you need to contact Opto 22 Product Support for assistance in using an I/O unit or controller, it is helpful to have device and firmware information at hand before you call us.

1. Choose Start > Programs > Opto 22 > PAC Project > PAC Manager.
2. In the PAC Manager main window, click the Inspect button .
3. In the Device Name field, type the controller’s name (normally the I/O unit name you defined in PAC Control; or you can type the controller’s IP address). Click Status Read.

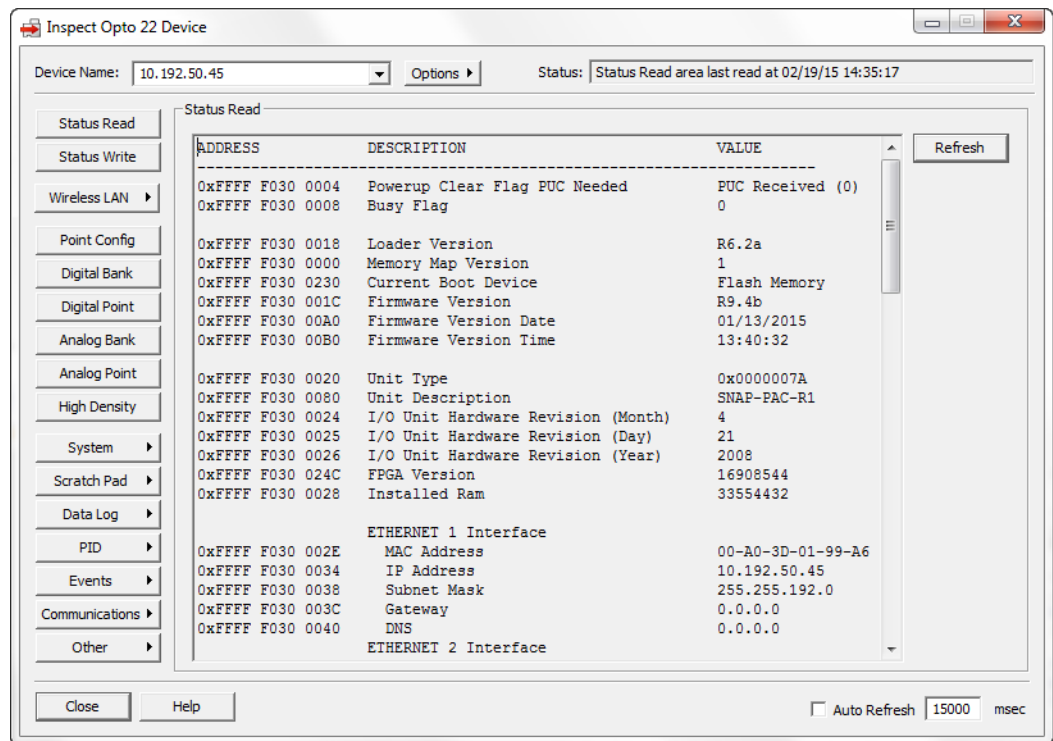

Keep this window open on your screen when you call Product Support.

## Communicating with the Controller

If you attempt to connect to the controller using its IP address and you cannot, first check the following:

- Make sure the controller has been turned on and the LNK and STAT LEDs for the connected Ethernet interfaces are lit (see [“Connectors and LEDs” on page 28.](#))
- Make sure the controller is mounted on a SNAP PAC rack.
- Make sure the controller’s hold-down screw has been tightened so that it is firmly attached to the rack.
- Verify that you typed in the correct address for the controller. Check the label on the side of the controller, where the IP address should be written. There are two labels, one for each Ethernet port, so make sure to look at the right one.
- Make sure the controller has been assigned a valid IP address and subnet mask. SNAP PAC R-series controllers come from the factory with a default IP address of 0.0.0.0, which is invalid. The default subnet mask is 255.255.255.0. To assign an IP address and subnet mask, see the *PAC Manager User’s Guide*.
- Make sure that no red LEDs on the controller are lit. A red LED could indicate a voltage supply problem. Each controller should have its own power supply. The controller needs a minimum of 5.0 VDC, measured at the rack.
- Make sure you have up-to-date drivers installed on your computer’s Network Interface Card (NIC). Contact your system administrator or the manufacturer of the card for help.
- Make sure you have Administrator privileges on your computer and that any firewall in the computer (such as the built-in firewall in Windows) is temporarily disabled before you try to assign or change IP addresses, load firmware using PAC Manager’s Maintenance window, or work with files on the controller. BootP and FTP cannot function through a firewall in the PC. Firewalls in a router are less likely to be a problem unless certain ports (such as FTP client) have been blocked, either by default or on purpose.

### Pinging the Controller

If you still cannot communicate with the controller after you have checked these items, try to reach it using the PING protocol.

1. Choose Start > Programs > Accessories and open a command prompt.
2. At the prompt, type: `ping [controller’s IP address]`  
For example, type: `ping 10.192.54.40`

**If the controller responds**, go to [“Accessing the Controller with PAC Manager” on page 52.](#)

**If the PING command cannot be found**, choose Start > Control Panel > Network. Make sure TCP/IP is configured as a protocol and that an IP address and subnet mask are assigned.

**If you see the message “Destination host route not defined,”** the controller probably has an inappropriate IP address and subnet mask. Make sure the IP address and subnet mask on the controller are compatible with those on the computer. Follow the directions beginning on [page 35](#) to check the IP address and subnet mask on the controller, and change them if necessary.

**If you see the message “No response from host,”** check the following:

- Are the computer and controller correctly connected? Is the controller turned on?
- Are the IP address and subnet mask on the controller compatible with those on the computer?
- Is the controller in reset mode? (Check for a blinking STAT LED. STAT blink codes are shown on [page 49.](#))

**If you still cannot ping the controller**, contact Opto 22 Product Support. (See [page 5.](#))

### Accessing the Controller with PAC Manager

Once you know you can ping the controller, try to access it using PAC Manager. You will need to know the controller’s IP address.

1. If PAC Manager is not already open, choose Start > Programs > Opto 22 > PAC Project > PAC Manager. The PAC Manager main window opens:

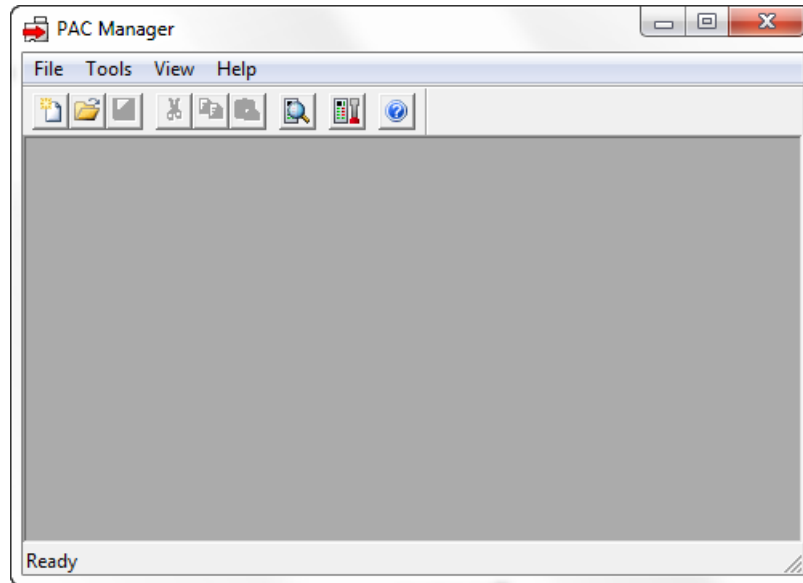

2. In the PAC Manager main window, click the Inspect button .
3. In the Device Name field, type the name (or IP address) of the controller (or choose it from the drop-down list). Press Enter or click Status Read.

Information from the controller is displayed in the window:

ADDRESS	DESCRIPTION	VALUE
0xFFFF F030 0004	Powerup Clear Flag PUC Needed	PUC Received (0)
0xFFFF F030 0008	Busy Flag	0
0xFFFF F030 0018	Loader Version	R6.2a
0xFFFF F030 0000	Memory Map Version	1
0xFFFF F030 0230	Current Boot Device	Flash Memory
0xFFFF F030 001C	Firmware Version	R9.4b
0xFFFF F030 00A0	Firmware Version Date	01/13/2015
0xFFFF F030 00B0	Firmware Version Time	13:40:32
0xFFFF F030 0020	Unit Type	0x0000007A
0xFFFF F030 0080	Unit Description	SNAP-PAC-R1
0xFFFF F030 0024	I/O Unit Hardware Revision (Month)	4
0xFFFF F030 0025	I/O Unit Hardware Revision (Day)	21
0xFFFF F030 0026	I/O Unit Hardware Revision (Year)	2008
0xFFFF F030 024C	FPGA Version	16908544
0xFFFF F030 0028	Installed Ram	33554432
ETHERNET 1 Interface		
0xFFFF F030 002E	MAC Address	00-A0-3D-01-99-A6
0xFFFF F030 0034	IP Address	10.192.50.45
0xFFFF F030 0038	Subnet Mask	255.255.192.0
0xFFFF F030 003C	Gateway	0.0.0.0
0xFFFF F030 0040	DNS	0.0.0.0
ETHERNET 2 Interface		

If information does not appear, contact Product Support. (See [page 5](#).)

### Solving Network Problems

If there are recurring problems in communicating with the controller, check your network. The wires, switches, and so on in your Ethernet network are not part of the Opto 22 hardware, but any problems in your network may affect communication with Opto 22 products.

**Create a Network Diagram.** First, create a network diagram and verify the following:

- Cable connectors are firmly inserted.
- The switch has power. Switch LEDs indicate that the connection is up.
- Neither the PC nor the controller uses the switch’s uplink port.
- The SNAP PAC R-series controller’s LNK LED is lit.

**Check Ethernet Errors.** Next, use PAC Manager to check Ethernet errors reported by the controller. These errors indicate network problems. You will need to know the controller’s IP address.

1. Choose Start > Programs > Opto 22 > PAC Project > PAC Manager.
2. In the PAC Manager main window, click the Inspect icon .
3. In the IP Address field, type the IP address of the controller. Click Status Read.
4. Scroll down until you see the items Ethernet Errors: Late Collisions, Ethernet Errors: Excessive Collisions, and Ethernet Errors: Others.

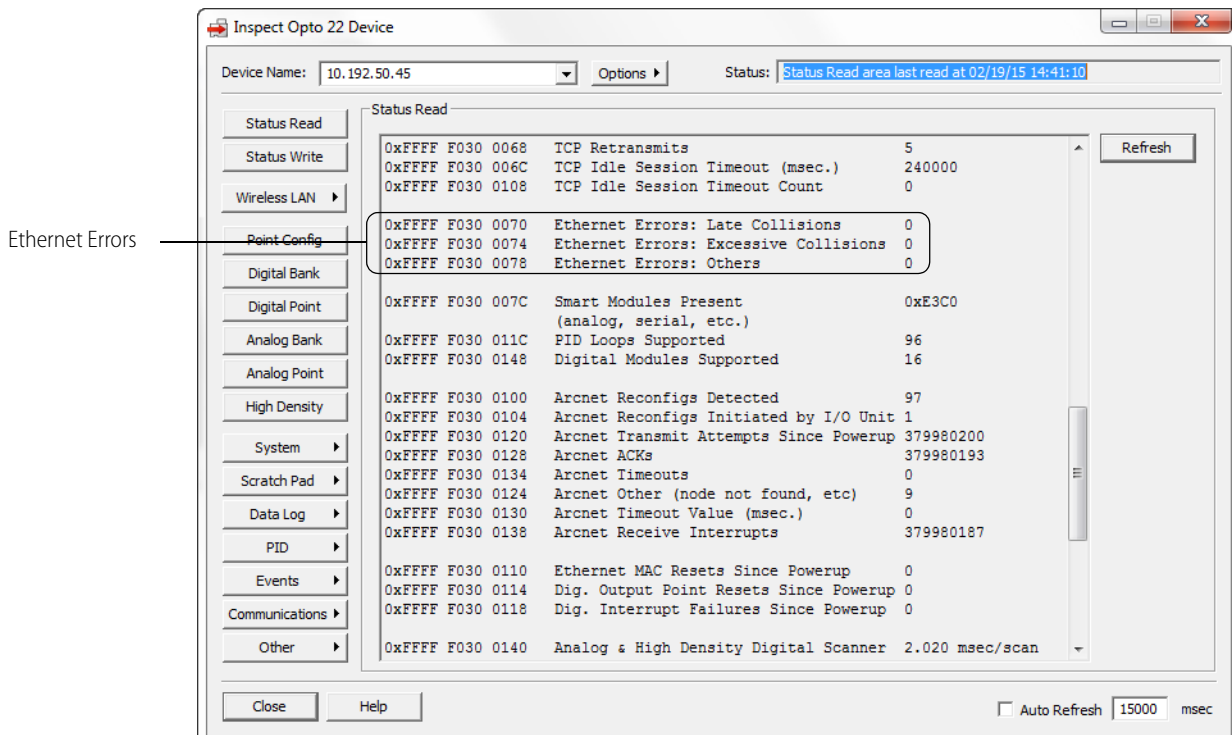

All three of these items should have a value of zero. If any of these items has a value other than zero, you may have a network problem.

**Analyze Communication Packets.** If it appears that you have network problems, you can use the OptoEnetSniff™ utility to log and analyze network communication packets. The utility is included with PAC Project Basic and PAC Project Professional software suites, and is available on our website, www.opto22.com. For help using the utility, see its online help file (choose Help > Contents).

**Have Your Network Certified.** If you suspect network problems, you may need to have your network professionally certified. Opto 22 does not offer network validation or certification services, but many network hardware manufacturers do. Contact the manufacturer of your Ethernet network hardware to have them diagnose, fix, and certify your network.

If you continue to have problems communicating with the SNAP PAC R-series controller after your network is certified, contact Opto 22 Product Support. (See page 5.)

## Additional Troubleshooting Tools

### Making Sure the Controller is in Normal Mode

If you are having trouble communicating with the controller, it might be in *fail-safe bootloader mode* or *hardware test mode*. The controller restarts in one of these modes if you hold down the RESET button longer than the time needed to restore the default settings. For more information, see [“Resetting the Controller” on page 36](#).

### TCP Settings

Retransmit timeout (RTO) refers to the length of time the controller waits while communicating before timing out. The RTO is determined by the controller’s TCP/IP stack, and the stack continually recalculates the RTO based on recent network traffic. If the network becomes busier, for example, the stack automatically adjusts the RTO to a higher value.

If the TCP/IP stack times out while trying to transmit data, it doubles the current RTO and tries again. This process continues for five retries; after that, the device stops trying and sends a timeout message.

If you are receiving frequent timeout messages from the device, you can change the TCP parameters in PAC Manager.

1. Start PAC Manager:
  - In Windows 7, click the Windows Start button, and then click All Programs > Opto 22 > PAC Project 10.0 > PAC Manager 10.0.
  - In Windows 10, click the Windows Start button and type Opto 22 > PAC Manager 10.0.
2. In the PAC Manager main window, click the Inspect icon .
3. In the Device Name field, type the name or IP address of the controller. Then, click Status Write.

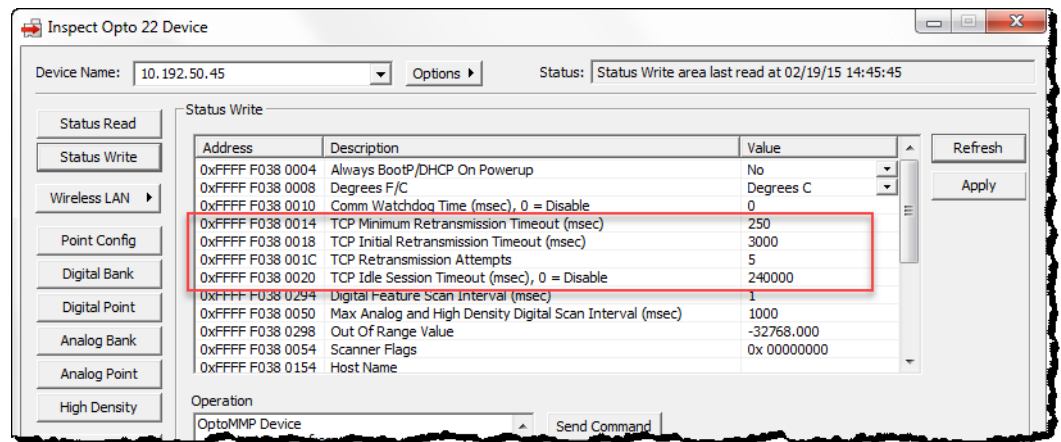

**CAUTION:** Note the following recommended settings:

TCP Minimum Retransmission Timeout (msec):	250
TCP Initial Retransmission Timeout (msec):	3000
TCP Retransmission Attempts:	5
TCP Idle Session Timeout (msec):	240,000

If you set these fields too low, you may not be able to communicate with the device at all—even through PAC Manager—to fix the settings. Then you would have to reset the controller to factory defaults.

4. Change these four fields as necessary:
  - Minimum RTO** sets an absolute minimum value for the RTO. The device's calculated RTO will never go below this value.
  - Initial RTO** sets the RTO for the first communication try. Be careful: since all future tries are based on this value, if you set it too low for network conditions, a connection will never be made.
  - TCP Retransmits** sets the number of times the device retries communication. Larger, busier networks need a higher number of retransmits than smaller networks with less traffic.
  - TCP idle session timeout** sets how long (in milliseconds) the device allows a session to remain open without any activity. After this time, the device checks the session to make sure it is still good, and closes it if it is not. The default is 240,000 milliseconds, or four minutes.
5. Click the Apply button to write your changes to the controller.
6. In the Operation Commands list, highlight Store configuration to flash. Click Send Command.
7. In the Operation Commands list, highlight Restart brain from powerup. Click Send Command. The new TCP parameters are set.

## TROUBLESHOOTING I/O MODULES: FREQUENTLY ASKED QUESTIONS

### SNAP Digital Troubleshooting

#### **Q: I have a SNAP digital module that has stopped working. What may have caused this?**

A: Failure of SNAP digital I/O modules is very rare and normally caused by misapplication, miswiring, or using the module at the wrong logic voltage. As with Opto 22's other digital I/O module families, there is no one way in which SNAP I/O modules fail. Output modules normally fail in a different way than inputs.

Output modules usually fail open, or half-wave for AC, and the failure is typically caused by the application of too much current or by degradation of the semiconductor switch by overvoltage. Because the module is separated into two parts by the optical isolator, it is possible to have an output module that behaves properly on the logic side but is broken on the field side. The LED will in most cases continue to turn on and off as commanded by the driving logic device, even though the module has failed.

The first step to troubleshooting a failed output module is to check the fuse. If it is blown, simply replacing it should get the module working again. If the module continues to blow fuses, analyze the load to see if the module is really suitable for the application.

When input modules fail, they usually do so on the field side, typically from overvoltage or overcurrent resulting from overvoltage. Unlike output modules, an input module's LED normally will not function as expected when the module has failed.

#### **Q: I have an input module that seems to flicker when a voltage is applied to it. What is happening here?**

A: Some Opto 22 SNAP digital input modules contain full-wave rectifiers. In an AC application it is possible to destroy one-half of the rectifier and still have the module appear to function. The full-wave rectifier turns into a half-wave rectifier, causing the module to turn on and off at the line frequency when an input is applied. You may see this as flicker on the channel status LED, or it may be too fast to see.

Digital logic devices, being much faster than the human eye, can cause serious issues with this failure mode. For example, a digital counter attached to a failed module will count at the input frequency.

This failure occurs most commonly in applications where the input module is placed in parallel with an inductive load. When the load turns off, the voltage spike (the back-EMF) goes right through the module, destroying one-half of the bridge.



To significantly reduce the frequency of this type of failure, place a transorb or large R-C snubber in parallel with both the load and the input module.

**Q: I have an output module driving a load. The load turns on but never seems to turn off, unless I remove power from the module entirely. What might be happening?**

A: This issue may occur when using an output module with a high-impedance load, such as a neon lamp or a small solenoid. Loads like these often have relatively large initial currents but relatively small “hold-in” currents. The result is that the off-state leakage current through the module is sufficient to keep the load on, once it has been turned on.

The solution to this issue is to place a power resistor, sized for 8–10 times the rated maximum leakage current for the module, in parallel with the load. Make sure that this resistor has a high enough power rating for the application.

**Q: I have a new AC output driving a solenoid. It turns on once, but will not turn on again. What is going on?**

A: Some loads, like certain solenoids, some types of halogen lights, and some types of strobe lights incorporate a diode in series with the coil or filament. This causes the load to behave as a half-wave rectifier.

Opto 22 output modules have a built-in R-C snubber circuit in parallel with the output. The capacitor in this circuit charges up but cannot discharge through the series diode, causing a voltage to appear across the output terminals. Because the module must see a zero voltage across the terminals to come on, it can’t turn on again in this situation.

The solution is to find a lamp or solenoid that does not have an internal diode; a potential work-around would be to put a high-value resistor (several tens of kilohms) across the output terminals of the module, to allow the capacitor to drain.

**Q: I have an AC output module in a circuit, wired in series (ANDed) with another contact. When that other contact closes, my load turns on momentarily, even though my output module is off. Is my module broken?**

A: This situation arises when the output module does not see a voltage across its terminals. This occurs when another contact is wired in series with the module, between the module and the “hot” side of the supply. Because the module is totally isolated from field to logic, the field (or contact) side of the module must power itself from the attached line. Because of the pilot circuit in the module, the switching semiconductor is in an indeterminate state when there is no voltage across the module. It may turn on for up to a half cycle if it suddenly receives power. The pilot circuit realizes that the module is on but cannot turn it off until the voltage crosses zero again.

There is no easy solution to this issue. Typically a solution involves either maintaining a minimal voltage across the module, pre-wetting it with a low voltage, or absorbing the energy from the half-cycle turn-on with an R-C network in parallel with the load.

**Q: Why are all four loads connected to my SNAP output module coming on when I’m activating only one of the channels?**

A: The SNAP digital output is likely connected on the wrong side of the loads. Remember that all four channels share one fuse; thus one side of each output is common with one side of all the others. If the module is on the wrong side of the load, any one channel is effectively connected to all four. If the output is a SNK type, try switching to a SRC type, or vice versa. In AC applications, reverse the module wiring.

**Q: I keep having failures on one channel of my SNAP output module. Why might this be happening?**

A: Failures of only one of the four output channels would indicate an issue with the load being driven by that channel. Make sure that the load characteristics, including transients, do not exceed the specifications of the module. Also be sure that the module is properly transient protected, using either an R-C snubber (AC) or a

commutating diode (DC) across the load. Modules may also be protected through the use of transient voltage suppressors across the module itself.

### SNAP Analog Troubleshooting

SNAP analog modules require a fairly substantial amount of current due to their onboard isolation power inverters. Because of this, it is important to make certain that the entire SNAP installation is supplied with 5.0 to 5.2 V, even while under full load.

See Opto 22 form #1120, [SNAP Power Supplies Data Sheet](#), for help in determining the full load required for an I/O unit, which includes the brain or on-the-rack controller and all modules.

An insufficient power supply really means a power supply that cannot provide the full load current required by the brain and modules, or a power supply that is not adjusted to provide 5.00 to 5.20 VDC as measured at the rack. The SNAP equipment is designed with a fail-safe voltage watchdog feature that inhibits operation when power supply voltage levels get too low, thus eliminating the possibility of unintentional output or input. Opto 22 offers DIN-rail-mountable power supplies for use with SNAP I/O systems.

Keep in mind that unless you purchase an isolated module, the channels on a SNAP input or output module are not isolated from one another. Make certain that any transducers or equipment that these modules are used with are floating, isolated from local earth ground. If the equipment is not floating, make certain that the two pieces of equipment being connected are at the same ground potential in order to eliminate the possibility of a ground loop through the module. A ground loop through the module could result in almost anything, from inaccurate readings to failure of the module.

# A: SNAP Mounting Racks and Power Supplies

## INTRODUCTION

As shown in the illustration below, a SNAP PAC R-series I/O system has a SNAP PAC R-series controller, SNAP rack, power supply, and modules. This appendix includes wiring diagram examples for assembling your SNAP PAC R-series controller, SNAP PAC rack, and power supply. For more information, especially for wiring information on modules, see the data sheet and the installation or user's guide for your specific products.

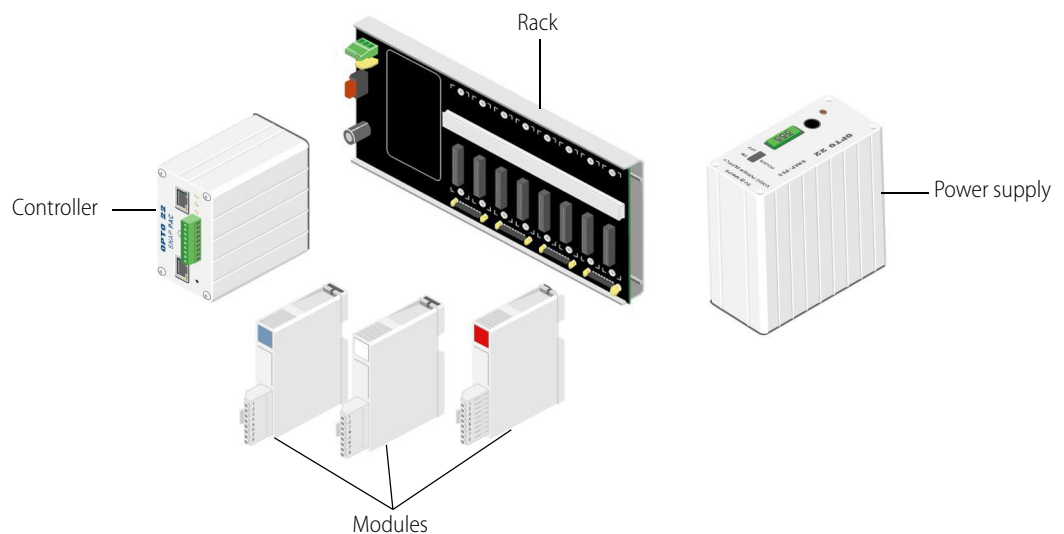

## SNAP MOUNTING RACKS

**CAUTION:** Make sure you are using the correct rack for your controller. Using the wrong rack will severely damage the controller. Correct racks are shown below:

Use these controllers	With these racks	More info
SNAP-PAC-R1 SNAP-PAC-R1-FM SNAP-PAC-R1-W SNAP-PAC-R2 SNAP-PAC-R2-FM SNAP-PAC-R2-W	SNAP-PAC-RCK4 SNAP-PAC-RCK4-FM SNAP-PAC-RCK8 SNAP-PAC-RCK8-FM	SNAP-PAC-RCK12 SNAP-PAC-RCK12-FM SNAP-PAC-RCK16 SNAP-PAC-RCK16-FM
		<a href="#">SNAP PAC Racks data sheet (form 1684)</a>

Use these controllers	With these racks	More info
SNAP-PAC-R1-B	SNAP-B4M SNAP-B8M SNAP-B8MC SNAP-B8MC-P SNAP-B12M	SNAP-B12MC SNAP-B12MC-P SNAP-B16M SNAP-B16MC SNAP-B16MC-P
		<a href="#">SNAP I/O Racks data sheet (form 0784)</a>

In this guide, SNAP PAC mounting racks are shown in all illustrations.

SNAP PAC mounting racks can hold an I/O processor (brain or rack-mounted controller) and up to 4, 8, 12, or 16 SNAP modules. A SNAP PAC rack is shown below with a SNAP PAC R-series controller installed, but no modules. All wiring connections are made to the field connectors on the top of each module.

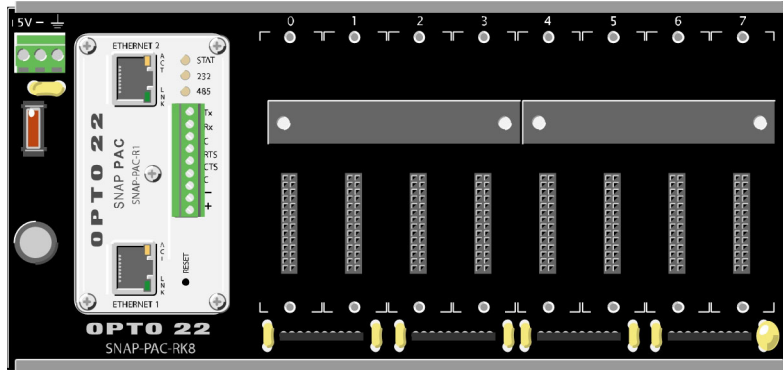

## SNAP POWER SUPPLIES

### Primary Power Supply

*NOTE: For a more general discussion of using power supplies with Opto 22 systems, see the [Using Power Supplies with Opto 22 Systems](#) technical note (form 1271).*

SNAP PAC racks use a 5 VDC power source (5 VDC [-0.0, +0.1] at minimum 4.0 amps recommended). For systems using AC source voltage, the SNAP-PS5 or SNAP-PS5U power supply is recommended. For DC systems, such as those using DC backup power, the SNAP-PS5-24DC offers DC-to-DC power.

In general, we recommend you **use an independent, isolated, regulated power supply locally with each rack**. Local isolated supplies offer these advantages:

- Short supply conductors, which minimize losses
- Power redundancy, so the failure of a single supply causes only a single rack failure, not a total system failure
- Fewer voltage drops and ground loops. (Voltage drops and subsequent ground loops may occur when power is distributed over a large system.)

Always **use a separate power supply for the field side of the I/O**. Using the rack supply for field actuation and monitoring defeats the isolation the I/O module offers and therefore increases the chance of a ground loop within the control system. Additionally, a sudden change of current on the field side can cause undesirable voltage fluctuations that may interfere with the computer's operation.

### Determining Power Requirements

Both the SNAP-PS5 and the SNAP-PS5-24DC power supplies provide 5 VDC power for loads up to 4 amps. The SNAP-PS5U provides 5 VDC for loads up to 5 amps. In most cases this power is sufficient for a SNAP processor, a rack, and the associated I/O modules. However, some combinations of modules, especially special-purpose modules, may require additional power. You can use the following table to help determine power needs for your I/O units.

Item	Quantity	X Power Req. (Amps)	Total Power Required (Amps) <sup>1</sup>
SNAP PAC R-series controller (except wired+wireless)	1	1.200	1.200 or
Wired+Wireless SNAP PAC R-series	1	1.500	1.500
SNAP-IDC5-SW digital input module			
SNAP-IDC5-SW-NC digital input module			
SNAP-AITM-8 analog input module		0.200	
Isolated analog input and output modules (part numbers ending in -i or iSRC) except SNAP-AITM-4i			
All other 4-channel digital input and output modules except mechanical relay outputs ( <i>not</i> high-density digital modules)		0.050	
SNAP mechanical power relay output modules		0.160	
SNAP-AICTD, AICTD-4 analog input modules			
High-density digital input and output modules			
SNAP-AIMA-32, SNAP-AIMA-iH, SNAP-AIV-32, and SNAP-AITM-4i analog input modules		0.150	
All analog output modules except SNAP-AOA-iSRC and SNAP-AOD-29-HFi			
SNAP-AOD-29-HFi		0.300	
SNAP-AIPM power monitoring module		0.100	
SNAP-AIPM-3, SNAP-AIPM-3V power monitoring modules			
SNAP-AILC and AILC-2 load cell modules		0.120	
SNAP-AIRTD-8U analog input module		0.135	
SNAP-AIARMS analog input module			
SNAP-AIVRMS analog input module			
SNAP-AICTD-8 analog input module			
SNAP-AIMA, AIMA-4, and AIMA-8 analog input modules		0.170	
SNAP-AITM and AITM-2 analog input modules			
SNAP-AIMV-4 and AIMV2-4 analog input modules			
SNAP-AIV, AIV-4, and AIV-8 analog input modules			
SNAP-AIRTD analog input module			
SNAP-AIR40K-4 analog input module		0.190	
SNAP-AIR400K-8 analog input module			
SNAP-AIRATE analog input module			
SNAP-AIRATE-HFi analog input module		0.210	
SNAP-SCM-ST2 and SNAP-SCM-SSI serial modules		0.200	
SNAP-SCM-232, SNAP-SCM-485-422, SNAP-SCM-PROFI			
SNAP-SCM-MCH16 <i>not</i> powering a breakout board		0.250	
SNAP-SCM-MCH16 powering a breakout board		0.700	
<b>Total</b>			

<sup>1</sup> Current from 5-volt supply

**IMPORTANT:** For a SNAP-PS5 or a SNAP-PS5-24DC power supply, the total power required must not exceed 4 amps. For a SNAP-PS5U, the total power required must not exceed 5 amps.

**Wiring the Primary Power Supply**

Use one power supply per I/O unit. Use 14 AWG wire.

1. Mount the SNAP-PS5 or SNAP-PS5-24DC power supply so that the attached red and black power wires will reach the + and – power terminals on the SNAP mounting rack.
2. Using the power terminals on the SNAP mounting rack, attach the red wire to the + terminal and the black wire to the – terminal. Connect the ground terminal on the SNAP rack to ground.
3. For the SNAP-PS5 (not illustrated): Using the removable input power connector on top of the power supply, apply 120 volts AC power between the two terminals marked “AC.” Connect the ground terminal to ground.
4. For the SNAP-PS5U (not illustrated): Using the removable input power connector on top of the power supply, apply 240 or 120 volts AC power between the two terminals marked “AC.” Connect the ground terminal to ground.
5. For the SNAP-PS5-24DC (illustrated below): Using the removable input power connector on top of the power supply, apply 24 volts DC power between the two terminals marked “±DC.” Connect the ground terminal to ground.

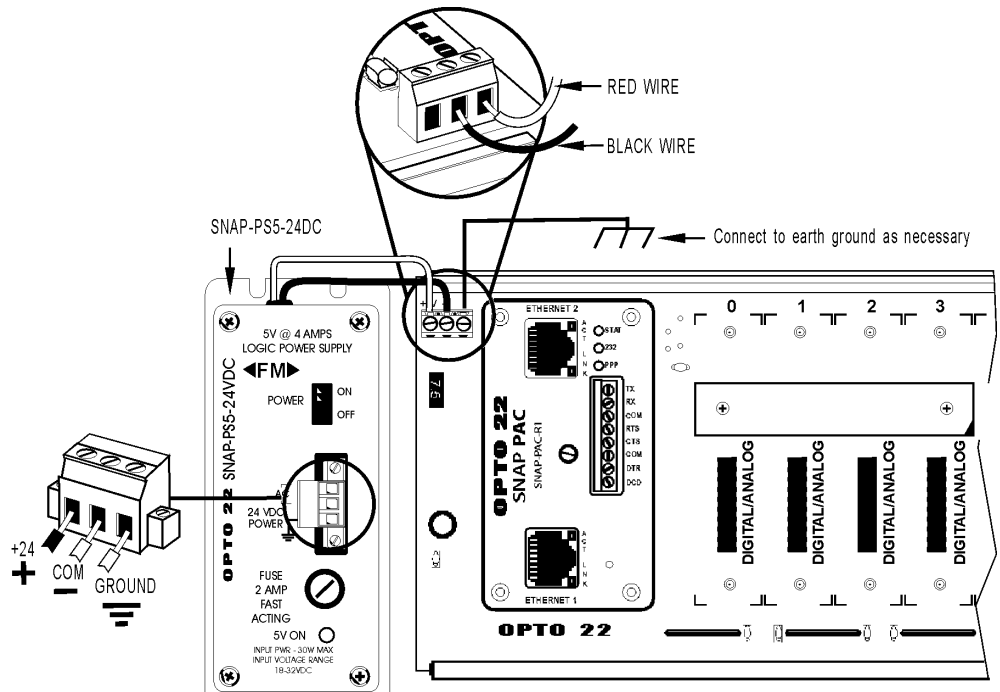

**Loop Power Supply**

Some analog modules (SNAP-AIMA, SNAP-AIMA-4, SNAP-AIMA-i, SNAP-AIMA2-i) also require a current loop supply, which can be provided by the SNAP-PS24 or the SNAP-PS24U. Both offer 24 volts of DC power, the SNAP-PS24 at .75 A and the SNAP-PS24U at 1.25 A. Follow these steps to wire these power supplies.

1. Mount the SNAP-PS24 or SNAP-PS24U power supply in a location where the attached output power wires will reach the field connector for SNAP analog modules.  
The white and red wire is the positive wire (24 VDC). The white and black wire is the negative wire (24 VDC return).
2. If you are wiring directly to the module, see the wiring diagram for the specific module you are using. Examples for an input module are shown in the following diagrams.

**SNAP-PS24**

In this diagram, the SNAP-PS24 power supply supplies power directly to the input module. The SNAP-PS5 supplies power to the rack.

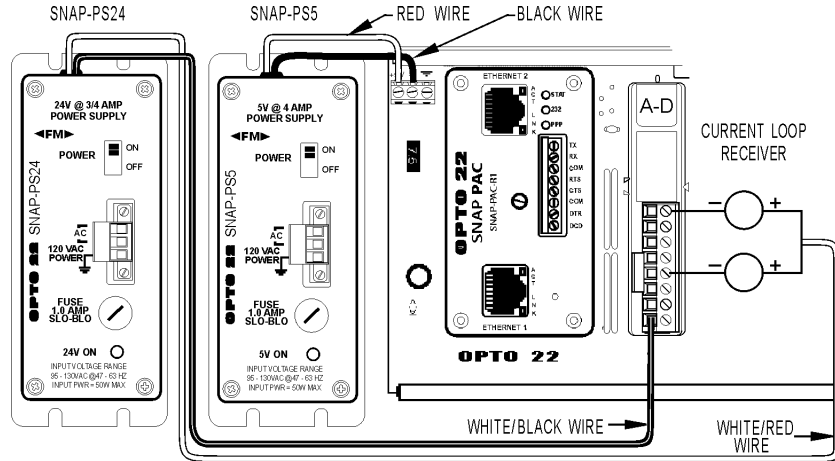

**SNAP-PS24U**

Here, the SNAP-PS24U power supply supplies power directly to the input module. The SNAP-PS5U supplies power to the rack.

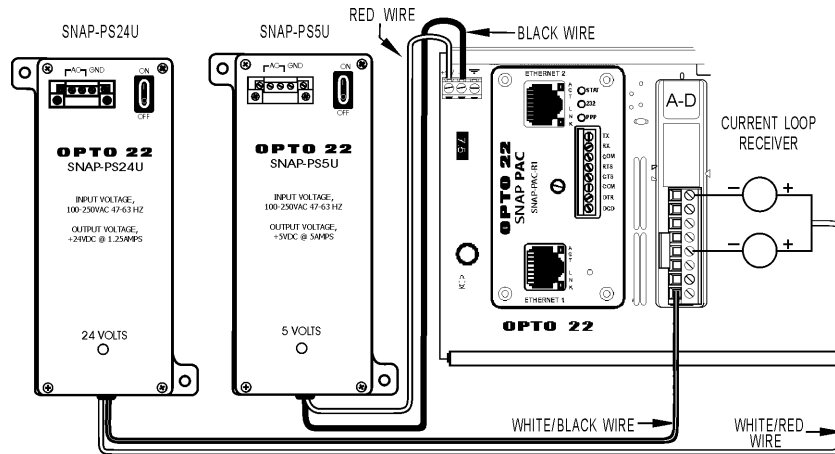





# Index

## Numerics

232 LED, 51

## A

accessing controller over the Internet, 14

analog input modules  
troubleshooting, 58

analog output modules  
troubleshooting, 58

analog point features, 31

API, 4

architecture  
network diagrams, 23  
average filter weight, 31

## B

battery, 35

blink codes, 49

## C

cable  
crossover, 22  
clamping, 31

communicating with controller  
peer-to-peer, 18  
pinging the controller, 52  
problems with, 52  
via modem, 12

communication  
choosing methods, 15  
Ethernet, 2  
serial, 2, 31  
simultaneous, 14  
with controller, 13  
with enterprise systems, 19

computer, connecting directly to controller, 22

configuring  
I/O points, 10  
modem communication, 11  
PPP, 11

connecting  
to controller, troubleshooting, 52  
to modem, 12  
to the enterprise, 19

control strategy, 17

controller  
installing, 9  
Scratch Pad, 19  
specifications, 27

controlling multiple I/O units, 17

counter  
high-speed, 30  
quadrature, 30

crossover cable, 22

current loop power supply, wiring, 62

## D

data  
delivering to databases, 19  
microSD card, 37

data, accessing via API, 4

developers, 4

dial-up networking  
configuring, 11

digital input modules  
troubleshooting, 56

digital output modules  
troubleshooting, 56

digital point features, 30

direct connection, 22

## E

- email, 19
- enterprise connectivity, 19
- enterprise management system, 19
- error codes
  - blink codes, 49
- Ethernet interface, 28
- Ethernet network
  - accessing controller over the Internet, 14
  - certification, 54
  - connecting controller to, 22
  - errors, 54
  - independent control network, 23
  - troubleshooting, 53

## F

- failsafe bootloader mode, 36, 55
- features, description of, 30
- files, in removable storage, 39
- filter weight, 31
- firmware
  - booting from microSD card, 45
  - disabling/enabling microSD updates, 49
  - loading new, 36
  - updating from microSD card, 44
- flowcharts, 17

## G

- gain, 31

## H

- hardware
  - getting data about, 51
  - installing, 7
- help
  - blink codes, 49
  - LED descriptions, 28
  - network problems, 53
  - Product Support, 5
- high-speed counters, 30

## I

- I/O, 2
- I/O modules
  - installing, 7
  - removing, 9
- I/O point
  - features, 30

- installing
  - controller (quick start), 7
  - controller on rack, 9
  - I/O modules, 7
  - modem, 12
  - mounting rack, 7
  - power supplies, 60
- Internet, accessing controller over, 14

## J

- JSON, 4

## L

- latches, 30
- LEDs
  - 232, 51
  - blink codes, 49
  - description, 28
  - PPP, 50
  - red, 52
  - STAT, 49
- loop power supply, 62

## M

- maximum value, 31
- memory map, 16, 19
- microSD card, 37
  - booting from card, 45
  - card type and format, 37
  - disabling/enabling updates via card, 49
  - replacing controller, 41
  - storing data, 39
  - updating firmware from card, 44
  - updating strategy, 47
- minimum value, 31
- Modbus/TCP, 19
- modem, 11
  - connecting to controller, 12
  - using PPP, 11
- mounting racks, 2
  - installing, 7

## N

- network
  - architecture, 22
  - architecture diagrams, 23
  - certification, 54
  - Ethernet errors, 54
  - independent, 23

- modem communication, 23
- OptoEnetSniff, 54
- segmented, 22
- troubleshooting, 53

NVRAM, 12

## O

- offset, 31
- OPC, 5, 19
- Opto 22 Product Support, 5
- OptoEnetSniff, 54
- output clamping, 31

## P

- PAC Control, 17, 47
- PAC Display, 17
- PAC Manager, 5
- peer-to-peer communication, 18
- PID loops, 32
- ping, 52
- point-to-point protocol, 23
- power supply
  - current loop, 62
  - determining requirements, 61
  - wiring, 60
- PPP, 23
  - configuring, 11
  - LED, 50, 51
- Product Support, 5

## Q

- quadrature counters, 30
- quick start, 7

## R

- rack for I/O modules, installing, 7
- removable storage, 37
- removing I/O modules, 9
- replacing controller, 41
- RESET button, 36, 55
- RESTful API, 4
- restore default settings, 36
- retransmit timeout (RTO), 55
- RS-232 port, 28

## S

- scaling, 31
- Scratch Pad areas, 19

- sdcard0, 39
- serial communication, 31
- serial port, 28
- SMTP, 19
- SNMP, 19
- specifications, 27
- STAT LED, 49
- status conditions (blink codes), 49
- strategy, 17, 47
  - disabling/enabling microSD updates, 49
- system architecture, 22

## T

- TCP/IP
  - multiple sessions, 14
  - settings, 55
  - stack, 55
- technical support, 5
- third-party software, 19
- timeout, 55
- troubleshooting
  - analog I/O modules, 58
  - blink codes, 49
  - digital I/O modules, 56
  - LED descriptions, 28
  - network, 53
  - Product Support, 5

## U

- utilities
  - OptoEnetSniff, 54

## W

- watchdog, 30, 31

