

# Legacy and Current SNAP Product Comparison and Compatibility Charts

## Software Suite Comparison: PAC Project™, ioProject™, FactoryFloor™

Software included	PAC Project Basic	PAC Project Pro	ioProject Basic	ioProject Pro	FactoryFloor
Control programming:	PAC Control™ Basic	PAC Control Pro	ioControl™ Basic	ioControl Pro	OptoControl™
HMI:	PAC Display™ Basic	PAC Display Pro	ioDisplay™ Basic	ioDisplay Pro	OptoDisplay™
Configuration:	PAC Manager™	PAC Manager	ioManager™	ioManager	--
OPC Server:	--	OptoOPCServer™	--	OptoOPCServer	OptoServer™
Database connectivity:	--	OptoDataLink™	--	--	-- <sup>a</sup>
Software-based PAC:	--	SoftPAC™	--	--	--

FEATURE		Current Software Suite: PAC Project								Legacy Software Suites		
		9.2 +		9.0 +		8.1 +		8.0		ioProject 7.1		Factory Floor 4.1
		Basic	Pro	Basic	Pro	Basic	Pro	Basic	Pro	Basic	Pro	
Compatible controllers (current)	SNAP PAC S-series	●	●	●	●	● <sup>b</sup>	● <sup>b</sup>	● <sup>b</sup>	● <sup>b</sup>	● <sup>b</sup>	● <sup>b</sup>	
	SNAP PAC R-series	●	●	●	●	● <sup>b</sup>	● <sup>b</sup>	● <sup>b</sup>	● <sup>b</sup>	● <sup>b</sup>	● <sup>b</sup>	
	SoftPAC software-based controller	●	●									
Compatible controllers (legacy)	SNAP-LCE SNAP Ultimate							c	c	●	●	
	SNAP-LCM4, SNAP-LCSX, SNAP-LCSX-PLUS, G4LC32 series, M4 and M4RTU series											●
Ethernet link redundancy or segmented control network			●		●		●		●		●	
Controller redundancy			●		●		●		●		●	
<b>Control Programming</b>												
Main features	Flowchart programming	●	●	●	●	●	●	●	●	●	●	●
	OptoScript™ programming	●	●	●	●	●	●	●	●	●	●	●
	Graphical debugger	●	●	●	●	●	●	●	●	●	●	●
	Subroutines	●	●	●	●	●	●	●	●	●	●	●
	Debug subroutines within strategy	●	●	●	●	●	●	●	●	●	●	
	Ramping, totalizing, pulsing, TPO, and frequency/period measurement on Ethernet-based brains that support these features	●	●	●	●		●		●		●	
	PAC Redundancy Manager utility		●		●							
	Conversion utility for OptoControl 4.1		●		●		●		●		●	
Conversion utility for Cyrano		d		d		d		d			●	
Maximum user charts running at once		16–32 <sup>e</sup>		16–32 <sup>e</sup>		16–32 <sup>e</sup>		16–32 <sup>e</sup>		8–32 <sup>e</sup>		31
Proportional-integral derivative (PID) loops	Number of PID algorithms (Ethernet)	4	4	4	4	4	4	4	4	4	4	-0-
	Number of PID algorithms ( <i>mistic</i> ™)	-0-	1	-0-	1	-0-	1	-0-	1	-0-	1	1
	PIDs per Ethernet brain	96	96	96	96	96	96	16–96 <sup>f</sup>	16–96 <sup>f</sup>			-0-
	PIDs per SNAP PAC serial brain	96	96	96	96	96	96					
	PIDs per <i>mistic</i> serial analog brain	-0-	8	-0-	8	-0-	8	-0-	8	-0-	8	8
Graphical PID tuner	●	●	●	●	●	●	●	●	●	●		
Integration Kits	Allen-Bradley® DF1	●	●	●	●	●	●	●	●	●	●	●
	Modbus® (serial)	●	●	●	●	●	●	●	●	●	●	●
	Modbus/TCP	●	●	●	●	●	●	●	●	●	●	
	DNP3	●	●	●	●	●	●					
	BACnet <sup>g</sup>	●	●	●	●							
Controller Area Network (CAN) <sup>h</sup>	●	●										

FEATURE		Current Software Suite: PAC Project								Legacy Software Suites		
		9.2 +		9.0 +		8.1 +		8.0		ioProject 7.1		Factory Floor 4.1
		Basic	Pro	Basic	Pro	Basic	Pro	Basic	Pro	Basic	Pro	
Developer Kits	OptoMMP™	●	●	●	●	●	●	●	●	●	●	
	Optomux		●		●		●		●			
	OptoControl SDK											●
<b>HMI Development</b>												
Main features	Alarming	●	●	●	●	●	●	●	●	●	●	●
	Trending	●	●	●	●	●	●	●	●	●	●	●
	Operator authentication and login	●	●	●	●	●	●	●	●	●	●	●
	3000-graphic library	●	●	●	●	●	●	●	●	●	●	●
	Ethernet link and scanner redundancy		●		●		●		●		●	
	Conversion utility for OptoDisplay		●		●		●		●		●	
	Conversion utility for <i>mistic</i> MMI											●
HMI controller data	SNAP PAC controllers	●	●	●	●	●	●	●	●	●	●	
	ioProject controllers	●	●	●	●	●	●	●	●	●	●	
	Ethernet FactoryFloor controllers		●		●		●		●		●	●
	Serial/ARCNET FactoryFloor controllers											●
Cyrano controllers											●	
<b>OPC Server</b>												
OPC server	OPC version 2.0 compatible		●		●		●		●		●	
	OPC version 1.0 compatible (and DDE)											●
<b>Database Connectivity</b>												
Databases supported	Built-in data transfer to Microsoft SQL Server, Microsoft Access, MySQL, and text files		●		●		●		●			a

a Some earlier versions of FactoryFloor included OptoConnect, which supported SQL 6 and Access 97.  
 b Wired+Wireless models (PNs ending in -W) require PAC Project 8.5+  
 c The software runs on the controller with 7.2 firmware; however, the controller cannot use some of the software's main features. See form #1688, the *SNAP PAC System Migration Technical Note*, for more information.  
 d Convert Cyrano to FactoryFloor, then FactoryFloor to PAC Project. See forms 1169 and 1692 for migration steps.  
 e Number of charts varies by controller: SNAP PAC S-series, 32; SNAP PAC R-series or SNAP-LCE, 16; SNAP Ultimate, 8. PAC Project 8.1 and higher work only with SNAP PAC controllers.  
 f Number of PIDs varies by brain: SNAP PAC brains and R-series, 96; SNAP Ultimate, 32; SNAP Ethernet, 16.  
 g Requires a SNAP-PAC-S1 or -S2 controller.  
 h Requires one or more SNAP-SCM-CAN2B modules.

**IMPORTANT:** If your system includes legacy controllers, do not upgrade to PAC Project 8.1 or higher. Instead, continue to use PAC Project 8.0 and firmware 7.2.

For PAC Project 8.1 or higher, use a SNAP PAC controller.

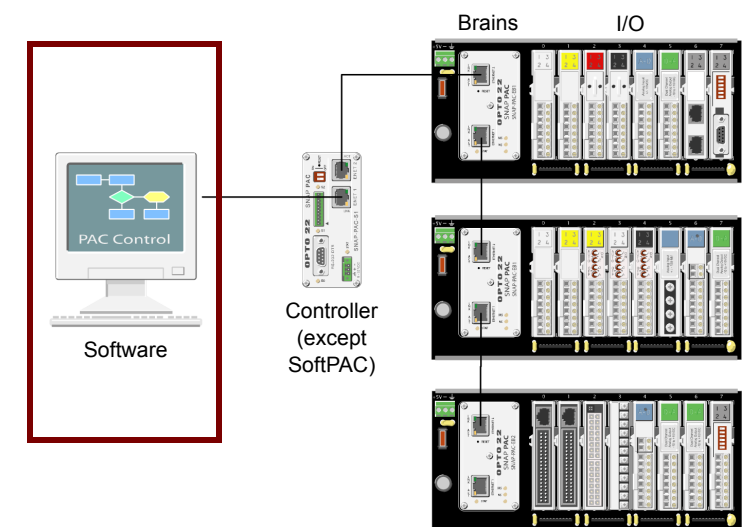

NOTE: Specifications may change without notice.

# Legacy and Current SNAP Product Comparison and Compatibility Charts

## SNAP Hardware Controller Comparison\*

FEATURE		Current Hardware						Legacy Hardware			
		SNAP-PAC-S1 SNAP-PAC-S1-FM **	SNAP-PAC-S1-W	SNAP-PAC-S2	SNAP-PAC-S2-W	SNAP-PAC-R1 SNAP-PAC-R1-B SNAP-PAC-R1-FM** SNAP-PAC-R2 SNAP-PAC-R2-FM**	SNAP-PAC-R1-W SNAP-PAC-R2-W	SNAP-LCE	SNAP Ultimate I/O	SNAP-LCM4 & M4-series	SNAP-LCSX & LCSX-PLUS
Communication with PC	Ethernet (10/100 Mbps)	● <sup>a</sup>	● <sup>a</sup>	● <sup>a</sup>	● <sup>a</sup>	● <sup>a</sup>	● <sup>a</sup>	●	●	● <sup>b</sup>	
	Wireless 802.11a/b/g		●		●		●				
	PPP (dial-up modem)	● <sup>c</sup>	● <sup>c</sup>	● <sup>d</sup>	● <sup>d</sup>	● <sup>e</sup>	● <sup>e</sup>	● <sup>f</sup>	● <sup>f</sup>		
	Serial (RS-232)									●	●
	ARCNET <sup>®</sup>									● <sup>g</sup>	
Communication with I/O	Ethernet (10/100 Mbps)	● <sup>a</sup>	● <sup>a</sup>	● <sup>a</sup>	● <sup>a</sup>	● <sup>a</sup>	● <sup>a</sup>	●	●	● <sup>b</sup>	
	Wireless 802.11a/b/g		●		●		●				
	Serial (RS-485)	1 port		up to 4 ports						2 or 4 ports	2 or 4 ports
	ARCNET									● <sup>g</sup>	
RS-232 port for modem use or for direct connection to serial devices using a PAC Control or ioControl strategy		2 ports <sup>c</sup>		up to 4 ports <sup>d</sup>		1 port <sup>e</sup>		2 ports	1 port		
Controller redundancy <sup>h</sup>		●	●	●	●						
RESTful API, HTTP/HTTPS server		●	●	●	●	●	●				
Modbus <sup>®</sup> /TCP (slave)		●	●	●	●	●	●	●	●	k	k
EtherNet/IP <sup>™</sup>		●	●	●	●	●	●				
Removable data storage (microSDHC card to 32 GB) <sup>i</sup>		●	●	●	●	●	●				
FTP server/client, file system		●	●	●	●	●	●				
Scratch Pad area for peer-to-peer communication		●	●	●	●	●	●				
SNMP (network management)		●	●	●	●	●	●				
Email (SMTP client)		●	●	●	●	●	●				
Real-time clock		●	●	●	●	●	●			●	●
32-bit processor		●	●	●	●	●	●			●	●
Floating-point unit (FPU)		●	●	●	●	●	●			● (LCM4)	
Total RAM (For more details, see form #1646.)		32 MB	128 MB	32 MB	128 MB	16 MB	32 MB	16 MB	16 MB	1–4 MB	1 MB
Battery-backed RAM		8 MB	8 MB	8 MB	8 MB	2 MB	2 MB	512 KB	512 KB	1–4 MB	1 MB
Flash EEPROM		16 MB	16 MB	16 MB	16 MB	8 MB	8 MB	8 MB	8 MB	256KB–2 MB	256 KB
Power requirements		8–32 VDC <sup>m</sup> (10 W max.)	8–32 VDC (11.3 W max.)	8–32 VDC (10 W max.)	8–32 VDC (11.3 W max.)	5 VDC @ 1.2 A (additional for I/O)	5 VDC @ 1.5 A (additional for I/O)	5 VDC @ 1.2 A	5 VDC @ 1.2 A (additional required for I/O modules)	5 VDC @ 2 A (1 A for controller; 1 A for Ethernet card)	5 VDC @ 500 mA
Backup battery		Rechargeable <sup>n</sup> (recharges when controller has power)		Rechargeable (recharges when controller has power)		Rechargeable <sup>o</sup> (recharges when controller has power)		CR2032, user replaceable	CR2032, fixed	3.6-volt lithium (Opto 22 part number G4BATT32)	
Size (inches)		4.05 L x 1.75 W x 4.17 H <sup>p</sup>		4.05 L x 2.75 W x 4.15 H <sup>p</sup>		3.30 L x 1.82 W x 3.50 H <sup>p</sup>		4.05 L x 1.75 W x 4.20 H	3.30 L x 1.82 W x 3.50 H	6.20 L x 5.80 W x 6.50 H	4.05 L x 1.75 W x 4.20 H
Size (centimeters)		10.29 L x 4.45 W x 10.59 H <sup>p</sup>		10.29 L x 6.99 W x 10.54 H <sup>p</sup>		8.38 L x 4.62 W x 8.89 H <sup>p</sup>		10.29 L x 4.45 W x 10.67 H	8.38 L x 4.62 W x 8.89 H	15.75 L x 14.73 W x 16.51 H	10.29 L x 4.45 W x 10.67 H
Operating Temperature		0 to 60 °C				0 to 60 °C		0 to 60 °C	0 to 60 °C	0 to 70 °C	0 to 70 °C
Storage Temperature		-40 to 85 °C				-40 to 85 °C		-40 to 85 °C	-40 to 85 °C	-40 to 85 °C	-40 to 85 °C
Humidity (non-condensing)		0–95%				0–95%		0–95%	0–95%	5–95%	5–95%

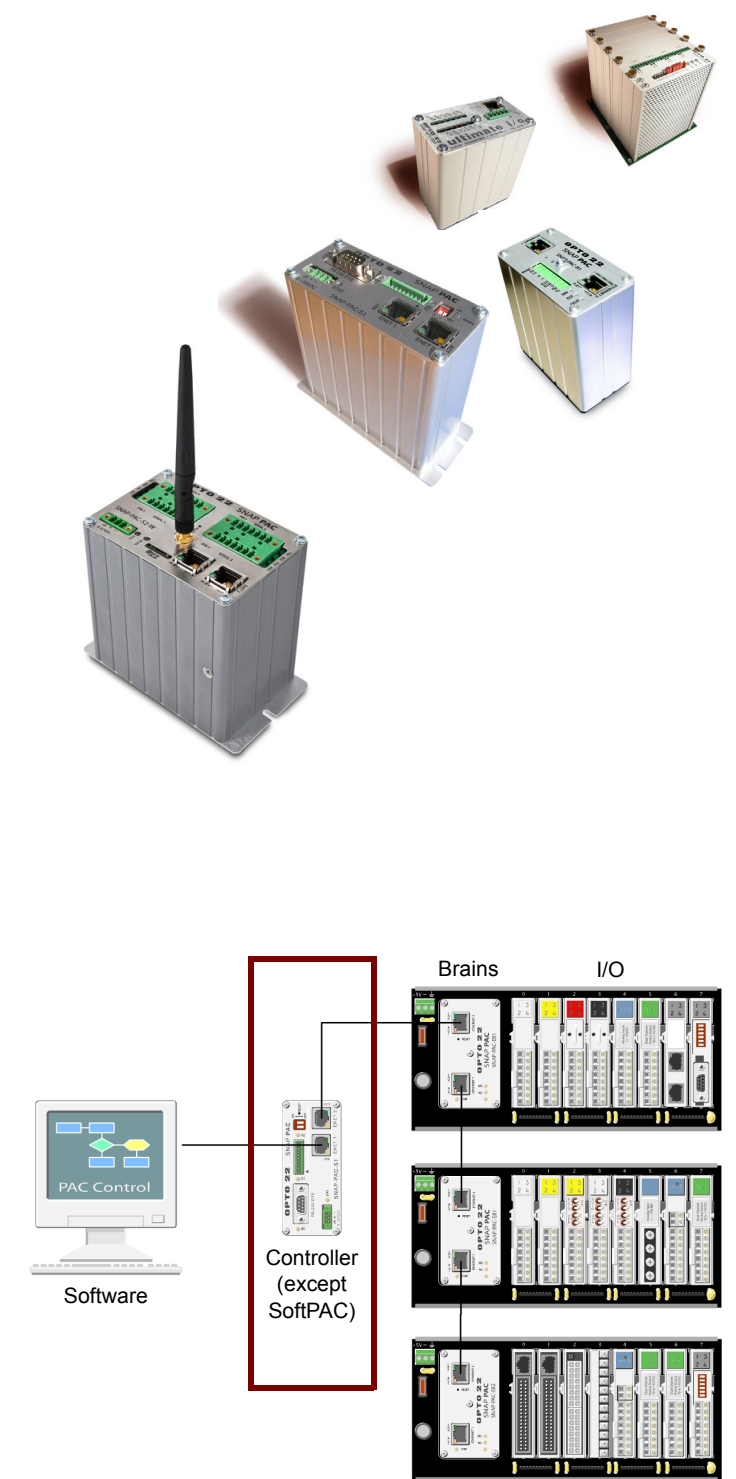

a Two Ethernet network interfaces for Ethernet link redundancy or segmenting networks  
 b With M4SENET-100 Ethernet adapter card (TCP/IP only)  
 c One port has DTR, DSR, CD, and RI signals plus bidirectional hardware flow control on RTS and CTS.  
 d All ports configurable for DTR & DCD signals plus bidirectional flow control on RTS & CTS. Configure only one port for PPP.  
 e DTR and CD signals plus bidirectional hardware flow control on RTS and CTS  
 f Bidirectional hardware flow control on RTS and CTS  
 g With ARCNET daughter card  
 h Requires two identical controllers, PAC Project Professional 9.0 or newer, and the SNAP PAC Redundancy Option Kit.

i Models manufactured before November 2008 do not have a microSD slot. SNAP-PAC-S models with a microSD slot must use firmware R8.3A or higher. Firmware 9.4a or higher and loader 6.1a or higher required for microSDHC card.  
 k Modbus Integration Kit for OptoControl could provide this functionality.  
 m S1s with serial numbers 500,000 and higher have an 8–32 VDC input voltage rating; units with serial number 499,999 and lower use 8–24 VDC. *Verify voltage on the unit's faceplate before applying power.*  
 n Models with serial numbers 625653 or lower have user-replaceable backup batteries.  
 o Models manufactured before August 2007 have user-replaceable backup batteries.  
 p See data sheet for additional dimensions on antenna for -W models.

NOTE: Specifications may change without notice.  
 \*To compare the SoftPAC software-based controller with hardware controllers, see form 2037, the [SNAP PAC Controller Comparison Chart](#).  
 \*\*OBSOLETE product, please contact Pre-Sales Engineering for more information.

## SNAP Ethernet Brain Comparison

FEATURE		Current Hardware										Legacy Hardware										
		SNAP PAC R-series					SNAP PAC Brains					SNAP Ultimate I/O		SNAP Ethernet I/O		SNAP Simple I/O						
		SNAP-PAC-R1	SNAP-PAC-R1-B	SNAP-PAC-R1-FM*	SNAP-PAC-R1-W	SNAP-PAC-R2	SNAP-PAC-R2-FM*	SNAP-PAC-R2-W	SNAP-PAC-EB1	SNAP-PAC-EB1-FM*	SNAP-PAC-EB1-W	SNAP-PAC-EB2	SNAP-PAC-EB2-FM*	SNAP-PAC-EB2-W	SNAP-PAC-SB1	SNAP-PAC-SB2	SNAP-UP1-ADS	SNAP-UP1-D64	SNAP-UP1-M64	SNAP-B3000-ENET	SNAP-ENET-D64	SNAP-ENET-S64
Digital I/O point features	Input latching	●	●	●	●	●	●	●	●	●	●	●	●	●	●	●	●	●	●	●	●	●
	On/off status	●	●	●	●	●	●	●	●	●	●	●	●	●	●	●	●	●	●	●	●	●
	Watchdog timer <sup>1</sup>	●	●	●	●	●	●	●	●	●	●	●	●	●	●	●	●	●	●	●	●	●
	High-speed counting (up to 20 kHz) <sup>2</sup>	●	●	●	●	●	●	●	●	●	●	●	●	●	●	●	●	●	●	●	●	●
	Quadrature counting <sup>3</sup>	●	●	●	●	●	●	●	●	●	●	●	●	●	●	●	●	●	●	●	●	●
	On-pulse and off-pulse measurement <sup>2,4</sup>	●	●	●	●	●	●	●	●	●	●	●	●	●	●	●	●	●	●	●	●	●
	Frequency and period measurement <sup>4</sup>	●	●	●	●	●	●	●	●	●	●	●	●	●	●	●	●	●	●	●	●	●
	Pulse generation (N pulses, continuous square wave, on-pulse, and off-pulse) <sup>4</sup>	●	●	●	●	●	●	●	●	●	●	●	●	●	●	●	●	●	●	●	●	●
	TPO (time-proportional output) <sup>4</sup>	●	●	●	●	●	●	●	●	●	●	●	●	●	●	●	●	●	●	●	●	●
	Digital totalizing <sup>4</sup>	●	●	●	●	●	●	●	●	●	●	●	●	●	●	●	●	●	●	●	●	●
Analog I/O point features	Thermocouple linearization (32-bit floating point linearized values)	●	●	●	●	●	●	●	●	●	●	●	●	●	●	●	●	●	●	●	●	●
	Minimum/maximum values	●	●	●	●	●	●	●	●	●	●	●	●	●	●	●	●	●	●	●	●	●
	Offset and gain	●	●	●	●	●	●	●	●	●	●	●	●	●	●	●	●	●	●	●	●	●
	Scaling (Engineering unit scaling)	●	●	●	●	●	●	●	●	●	●	●	●	●	●	●	●	●	●	●	●	●
	TPO <sup>3</sup>	●	●	●	●	●	●	●	●	●	●	●	●	●	●	●	●	●	●	●	●	●
	Output clamping	●	●	●	●	●	●	●	●	●	●	●	●	●	●	●	●	●	●	●	●	●
	Filter weight	●	●	●	●	●	●	●	●	●	●	●	●	●	●	●	●	●	●	●	●	●
	Watchdog timer	●	●	●	●	●	●	●	●	●	●	●	●	●	●	●	●	●	●	●	●	●
	Ramping <sup>4</sup>	●	●	●	●	●	●	●	●	●	●	●	●	●	●	●	●	●	●	●	●	●
Analog totalizing <sup>4</sup>	●	●	●	●	●	●	●	●	●	●	●	●	●	●	●	●	●	●	●	●	●	
Serial events	●	●	●	●	●	●	●	●	●	●	●	●	●	●	●	●	●	●	●	●	●	
PID logic on the brain—number of PID loops	96	96	96	96	96	96	96	96	96	96	96	96	96	96	96	32	32	16	●	●	●	
Digital events—expanded <sup>1</sup>	●	●	●	●	●	●	●	●	●	●	●	●	●	●	●	●	●	●	●	●	●	
Digital events—old <sup>2</sup>	●	●	●	●	●	●	●	●	●	●	●	●	●	●	●	●	●	●	●	●	●	
Alarm events	●	●	●	●	●	●	●	●	●	●	●	●	●	●	●	●	●	●	●	●	●	
Timed events <sup>5</sup>	●	●	●	●	●	●	●	●	●	●	●	●	●	●	●	●	●	●	●	●	●	
Event messaging	●	●	●	●	●	●	●	●	●	●	●	●	●	●	●	●	●	●	●	●	●	
UDP Streaming	●	●	●	●	●	●	●	●	●	●	●	●	●	●	●	●	●	●	●	●	●	
Email (SMTP client)	●	●	●	●	●	●	●	●	●	●	●	●	●	●	●	●	●	●	●	●	●	
OPC driver support	●	●	●	●	●	●	●	●	●	●	●	●	●	●	●	●	●	●	●	●	●	
Data logging in the brain	●	●	●	●	●	●	●	●	●	●	●	●	●	●	●	●	●	●	●	●	●	
Security, wired Ethernet network (IP filtering, port access)	●	●	●	●	●	●	●	●	●	●	●	●	●	●	●	●	●	●	●	●	●	

FEATURE	Current Hardware										Legacy Hardware										
	SNAP PAC R-series					SNAP PAC Brains					SNAP Ultimate I/O		SNAP Ethernet I/O		SNAP Simple I/O						
	SNAP-PAC-R1	SNAP-PAC-R1-B	SNAP-PAC-R1-FM*	SNAP-PAC-R1-W	SNAP-PAC-R2	SNAP-PAC-R2-FM*	SNAP-PAC-R2-W	SNAP-PAC-EB1	SNAP-PAC-EB1-FM*	SNAP-PAC-EB1-W	SNAP-PAC-EB2	SNAP-PAC-EB2-FM*	SNAP-PAC-EB2-W	SNAP-PAC-SB1	SNAP-PAC-SB2	SNAP-UP1-ADS	SNAP-UP1-D64	SNAP-UP1-M64	SNAP-B3000-ENET	SNAP-ENET-D64	SNAP-ENET-S64
Security, wireless network (WPA2-AES, WPA-TKIP, WEP)	●	●	●	●	●	●	●	●	●	●	●	●	●	●	●	●	●	●	●	●	●
Realtime clock (RTC)	●	●	●	●	●	●	●	●	●	●	●	●	●	●	●	●	●	●	●	●	●
I/O point data mirroring and memory map copying	●	●	●	●	●	●	●	●	●	●	●	●	●	●	●	●	●	●	●	●	●
Scratch Pad area	Bits	●	●	●	●	●	●	●	●	●	●	●	●	●	●	●	●	●	●	●	●
	Floats, integers, and strings	●	●	●	●	●	●	●	●	●	●	●	●	●	●	●	●	●	●	●	●
RESTful API, HTTP/HTTPS server	●	●	●	●	●	●	●	●	●	●	●	●	●	●	●	●	●	●	●	●	●
Modbus <sup>®</sup> /TCP (slave)	●	●	●	●	●	●	●	●	●	●	●	●	●	●	●	●	●	●	●	●	●
OptoMMP memory-mapped protocol	●	●	●	●	●	●	●	●	●	●	●	●	●	●	●	●	●	●	●	●	●
EtherNet/IP <sup>™</sup> (Allen-Bradley <sup>®</sup> RSLogix <sup>®</sup> systems)	●	●	●	●	●	●	●	●	●	●	●	●	●	●	●	●	●	●	●	●	●
SNMP (network management)	●	●	●	●	●	●	●	●	●	●	●	●	●	●	●	●	●	●	●	●	●
FTP server	●	●	●	●	●	●	●	●	●	●	●	●	●	●	●	●	●	●	●	●	●
FTP client	●	●	●	●	●	●	●	●	●	●	●	●	●	●	●	●	●	●	●	●	●
PPP (dial-up modem)	●	●	●	●	●	●	●	●	●	●	●	●	●	●	●	●	●	●	●	●	●
Serial (RS-232) port for PPP or serial devices	●	●	●	●	●	●	●	●	●	●	●	●	●	●	●	●	●	●	●	●	●
Ethernet networking (10/100 Mbps)	●	●	●	●	●	●	●	●	●	●	●	●	●	●	●	●	●	●	●	●	●
Dual independent Ethernet network interfaces (two IP addresses)	●	●	●	●	●	●	●	●	●	●	●	●	●	●	●	●	●	●	●	●	●
Dual switched Ethernet network interfaces (one IP address)	●	●	●	●	●	●	●	●	●	●	●	●	●	●	●	●	●	●	●	●	●
Wireless LAN interface (802.11a, b, or g)	●	●	●	●	●	●	●	●	●	●	●	●	●	●	●	●	●	●	●	●	●
Runs PAC Control strategies	●	●	●	●	●	●	●	●	●	●	●	●	●	●	●	●	●	●	●	●	●

\* OBSOLETE product, please contact Pre-Sales Engineering for more information.  
 1 High-density digital modules require brain firmware 8.1 or higher.  
 2 Four-channel modules only; not available on high-density digital modules.  
 3 Requires a special SNAP module (SNAP-IDC5Q for quadrature input, SNAP-AOD-29 for TPO).  
 4 Available when used with PAC Control Basic 9.x or PAC Control Professional 8.2 or newer and a SNAP PAC controller.  
 Frequency, period, and totalizing require PAC Project 8.1 or higher for R1, EB1, and SB1.  
 Totalizing, TPO, and pulse generation require PAC Project 8.2 for R2, EB2, and SB2.  
 5 In firmware 8.1, Timed events were merged into Digital Events—Expanded.  
 6 Serial port for PPP only.  
 7 See form #1692 for limitations.

For controller compatibility, see [page 4](#).  
 For I/O module compatibility, see [page 5](#).  
 For rack part numbers, see [page 4](#).

