

SNAP PAC SYSTEM SPECIFICATION GUIDE

Form 1696-230110—January 2023

OPTO 22
Your Edge in Automation.™

43044 Business Park Drive • Temecula • CA 92590-3614
Phone: 800-321-OPTO (6786) or 951-695-3000
Fax: 800-832-OPTO (6786) or 951-695-2712
www.opto22.com

Product Support Services
800-TEK-OPTO (835-6786) or 951-695-3080
Fax: 951-695-3017
Email: support@opto22.com
Web: support.opto22.com

SNAP PAC System Specification Guide
Form 1696-230110—January 2023

Copyright © 2007-2023 Opto 22.
All rights reserved.
Printed in the United States of America.

The information in this manual has been checked carefully and is believed to be accurate; however, Opto 22 assumes no responsibility for possible inaccuracies or omissions. Specifications are subject to change without notice.

Opto 22 warrants all of its products to be free from defects in material or workmanship for 30 months from the manufacturing date code. This warranty is limited to the original cost of the unit only and does not cover installation, labor, or any other contingent costs. Opto 22 I/O modules and solid-state relays with date codes of 1/96 or newer are guaranteed for life. This lifetime warranty excludes reed relay modules, *groov* and SNAP serial communication modules, SNAP PID modules, and modules that contain mechanical contacts or switches. Opto 22 does not warrant any product, components, or parts not manufactured by Opto 22; for these items, the warranty from the original manufacturer applies. Refer to Opto 22 form 1042 for complete warranty information.

Wired+Wireless controllers and brains are licensed under one or more of the following patents: U.S. Patent No(s). 5282222, RE37802, 6963617; Canadian Patent No. 2064975; European Patent No. 1142245; French Patent No. 1142245; British Patent No. 1142245; Japanese Patent No. 2002535925A; German Patent No. 60011224.

Opto 22 FactoryFloor, *groov*, *groov* EPIC, *groov* RIO, mobile made simple, The Edge of Automation, Optomux, and Pamux are registered trademarks of Opto 22. Generation 4, *groov* Server, ioControl, ioDisplay, ioManager, ioProject, ioUtilities, *mistic*, Nvio, Nvio.net Web Portal, OptoConnect, OptoControl, OptoDataLink, OptoDisplay, OptoEMU, OptoEMU Sensor, OptoEMU Server, OptoOPCServer, OptoScript, OptoServer, OptoTerminal, OptoUtilities, PAC Control, PAC Display, PAC Manager, PAC Project, PAC Project Basic, PAC Project Professional, SNAP Ethernet I/O, SNAP I/O, SNAP OEM I/O, SNAP PAC System, SNAP Simple I/O, SNAP Ultimate I/O, and Wired+Wireless are trademarks of Opto 22.

ActiveX, JScript, Microsoft, MS-DOS, VBScript, Visual Basic, Visual C++, Windows, and Windows Vista are either registered trademarks or trademarks of Microsoft Corporation in the United States and other countries. Linux is a registered trademark of Linus Torvalds. ARCNET is a registered trademark of Datapoint Corporation. Modbus is a registered trademark of Schneider Electric, licensed to the Modbus Organization, Inc. Wiegand is a registered trademark of Sensor Engineering Corporation. Allen-Bradley, CompactLogix, ControlLogix, MicroLogix, SLC, and RSLogix are either registered trademarks or trademarks of Rockwell Automation. CIP and EtherNet/IP are trademarks of ODVA. Raspberry Pi is a trademark of the Raspberry Pi Foundation. The registered trademark Ignition by Inductive Automation® is owned by Inductive Automation and is registered in the United States and may be pending or registered in other countries. CODESYS® is a registered trademark of 3S-Smart Software Solutions GmbH.

groov includes software developed by the OpenSSL Project for use in the OpenSSL Toolkit. (<http://www.openssl.org>)

All other brand or product names are trademarks or registered trademarks of their respective companies or organizations.

Opto 22
Your Edge in Automation.

Table of Contents

Chapter 1: Introduction	1
The SNAP PAC System.....	1
Compatibility with other Opto 22 products	1
SNAP PAC System Architecture	2
Example #1: Minimal Initial System	2
Example #2: Small Initial System	3
Expanding Your System	4
Adding More Distributed I/O	4
Adding More HMI Seats	5
Adding Cybersecurity, IIoT Capabilities, and Mobile Operator Interfaces	5
Adding Large Numbers of Additional I/O	6
Combining Serial and Ethernet Distributed I/O	8
Delivering SNAP PAC System Data to Company Databases	9
Communicating with Third-Party Systems	9
Using Redundant Networking	10
Incorporating Legacy Opto 22 Systems	11
What's In this Guide.....	12
Related Documents	12
SNAP PAC System Data Sheets	12
SNAP PAC System User's Guides	13
Other Useful SNAP PAC System Documents	14
For Help	14
Sales	14
Product Support	14
Chapter 2: Choosing System Components	17
Introduction	17
Building a SNAP PAC System	17
Steps to Build a SNAP PAC System	18
Choosing Software.....	19
PAC Project Basic and Professional Comparison Chart	19
Choosing Controllers.....	21
Choosing Brains.....	23
SNAP PAC Controller and Brain Comparison Chart	23

Choosing I/O	26
About Isolation	26
Digital Input Modules	27
Digital Output Modules	27
SNAP Digital Q&A	29
Analog Input Modules	30
Analog Output Modules	32
SNAP Analog Q&A	32
Serial Communication Modules	33
I/O Mounting Racks	33
Choosing Power Supplies	33
Primary Power Supply	33
Determining Power Requirements	34
Loop Power Supply	36
Warranty Information and FM Approval	36
Simplifying Installation with SNAP TEX Accessories	36
Module, Breakout Board, and Cable Compatibility Charts	37
4-Channel Digital Modules	37
1-, 2-, and 4-Channel Analog Modules	38
High-Density Digital Modules	39
Analog Modules with More Than 4 Points	39
DIN-Rail Clips and Kits	40
Chapter 3: Networking Options	41
Introduction	41
Network Interfaces on SNAP PAC Controllers and Brains	42
SNAP-PAC-S1 Controller—Network Interfaces and Ports	42
SNAP-PAC-S2 Controller—Network Interfaces and Ports	43
SNAP PAC R-Series Controllers—Network Interfaces and Ports	44
SNAP PAC EB Brains—Interfaces	45
SNAP PAC SB Brains—Ports	45
Ethernet Networking Options	46
Standard Ethernet Network Usage	46
Alternatives to Standard Usage	46
Using Redundant Ethernet Network Links	46
Isolating Ethernet Networks into Zones	48
Communicating with Modbus/TCP Systems	48
Communicating with Allen-Bradley PLC Systems	49
Exchanging data between an A-B PLC system and a SNAP PAC System	49
Serial Network Options	50
Using Distributed Serial I/O	50
Connecting Directly to Serial Devices	50
Communicating with a Remote Host Using a Modem	50
Communicating with Legacy Serial <i>mistic</i> I/O Units	51
Chapter 4: Installing and Wiring System Components	53
Introduction	53
Downloading and Installing Software	53

Firmware	53
Mounting Controllers	53
Installing I/O Processors and I/O Modules	54
Installing I/O Modules	54
Removing a Module	55
Installing the Brain or Rack-Mounted Controller	55
Setting Up Ethernet Networking	55
Setting Up Serial Networking	56
Wiring Power Supplies	59
Primary Power Supply	59
Loop Power Supply	59
Wiring I/O Modules	61
4-Channel Digital Input Modules	61
4-Channel Digital Output Modules	63
High-Density Digital Modules	68
Analog Input Modules	74
Analog Output Modules	91
Serial Communication Modules	96
Appendix A: I/O Specifications	99
Introduction	99
Digital Input Module Specifications	100
SNAP-IDC5Q	104
SNAP-IDC5-SW and SNAP-IDC5-SW-NC	104
Digital Output Module Specifications	106
Analog Input Module Specifications	116
SNAP-AIARMS	116
SNAP-AIARMS-i	116
SNAP-AILC and SNAP-AILC-2	117
SNAP-AIMA-32	120
SNAP-AIMA2-i	120
SNAP-AIMA-i	121
SNAP-AIRATE-HFi	123
SNAP-AITM-4i	129
SNAP-AITM2-i	129
SNAP-AIV-i	130
SNAP-AITM-i	131
SNAP-AIV2-i	133
SNAP-AIVRMS-i	135
Analog Output Module Specifications	136
SNAP-AOA-3	136
SNAP-AOVA-8	142
Serial Module Specifications	143
SNAP-SCM-232 and SNAP-SCM-485-422	143
SNAP-SCM-ST2	143
SNAP-SCM-CAN2B	144
Breakout Board and Cable Specifications	145
SNAP-IDC-HDB and SNAP-ODC-HDB	146

SNAP-UDC-HDB	147
SNAP-UDC-HDB-G4	147
SNAP-HD-ACF6, SNAP-HD-CBF6, and SNAP-HD-BF6	148
SNAP-TEX-CBO6, SNAP-TEX-CBE6, and SNAP-TEX-CBS6	148

Appendix B: Dimensional Diagrams 149

Introduction	149
SNAP PAC Controller Diagrams	150
SNAP-PAC-S1 Standalone Controller	150
SNAP-PAC-S2 Standalone Controller	151
SNAP-PAC-R1, SNAP-PAC-R1-FM, and SNAP-PAC-R2, Rack-mounted Controllers	152
SNAP PAC Brain Diagrams	153
SNAP-PAC-SB1 and SNAP-PAC-SB2 Serial Brains	153
SNAP Power Supplies Diagrams	154
SNAP-PS5, SNAP-PS24, and SNAP-PS5-24DC	154
SNAP-PS5U and SNAP-PS24U	155
SNAP Digital I/O Modules Diagrams	156
SNAP Digital Input Modules—All Modules except MA	156
SNAP Digital Input Modules—MA Modules	157
SNAP Digital Output Modules—All Modules except MA and Mechanical Power Relay	158
SNAP Digital Output Modules—MA Modules	159
SNAP Digital Output Modules—Mechanical Power Relay	160
SNAP High-Density Digital Modules	161
SNAP 16-Point Digital Modules	161
SNAP 32-Point Digital Modules	162
SNAP Analog I/O Modules	163
SNAP Analog Input Modules—Most Two- and Four-Channel Modules	163
SNAP Analog Input Modules—SNAP-AITM-8	164
SNAP Analog Input Modules—SNAP-AICTD-8, SNAP-AIMA-8, and SNAP-AIV-8	165
SNAP-AIR400K-8 Analog Input Module	166
SNAP-AIRTD-8U Analog Input Module	167
SNAP Analog Input Modules—32-Channel	168
SNAP Isolated Analog Input Modules—Most Modules	169
SNAP Isolated Analog Input Modules—SNAP-AITM-i and SNAP-AITM2-i	170
SNAP Analog Input Modules—SNAP-AITM-4i	171
SNAP Analog Output Modules—All modules except SNAP-AOA-23-iSRC, SNAP-AOA-23-iSRC-FM, and SNAP-AOVA-8	172
SNAP Analog Output Modules—SNAP-AOA-23-iSRC and SNAP-AOA-23-iSRC-FM only	173
SNAP Analog Output Modules—SNAP-AOVA-8 only	174
SNAP Serial Modules	175
SNAP-SCM-232	175
SNAP-SCM-485-422	176
SNAP-SCM-ST2 and SNAP-SCM-CAN2B	177
SNAP Breakout Boards and Racks Diagrams	178
SNAP-IDC-HDB Breakout Rack	178
SNAP-ODC-HDB Breakout Rack	178
SNAP-UDC-HDB Breakout Rack	179
SNAP-UDC-HDB-G4 Breakout Rack	179

SNAP-AIMA-HDB Breakout Rack	180
SNAP-AIV-HDB Breakout Rack	180
SNAP-TEX-32 Breakout Board	181
Index	183

1: Introduction

THE SNAP PAC SYSTEM

First released in 2007, the SNAP PAC System™ is an integrated system of hardware and software from Opto 22 for industrial control, remote monitoring, and data acquisition applications. Designed to simplify the typically complex process of understanding, selecting, buying, and applying an automation system, the SNAP PAC System consists of four integrated components:

PAC Project™ Software Suite—easy-to-use flowchart-based control programming, HMI (human-machine interface) development and runtime, plus optional OPC server, database connectivity software, and software-based controller for PC-based control

SNAP PAC controllers—standalone or rack-mounted industrial controllers with networking options and a RESTful API, or a software-based controller

SNAP PAC brains—intelligent I/O processors for distributed control on Ethernet and serial networks

SNAP I/O™—analog, digital, and serial I/O modules for connecting to field devices, machines, and sensors

These four simple but flexible components form a system capable of handling any application from basic equipment monitoring to complete factory automation.

IMPORTANT: *As of 2022, we are no longer able to manufacture some SNAP PAC System components due to the unavailability of essential parts. This guide recommends alternative components you can use if the original is now obsolete.*

Compatibility with other Opto 22 products

The SNAP PAC System remains compatible with both newer and older Opto 22 system families, including:

- **groov EPIC system**— Add *groov* EPIC to your SNAP PAC System for improved system cybersecurity. Run your PAC Control strategy on the EPIC instead of a SNAP PAC controller—EPIC can control SNAP I/O units—and make sure all communication goes through the EPIC. You gain password protection for your system and other important security features, as well as the ability to more easily share data with diverse legacy equipment, on-premises software, cloud services, and other places where you need it. For more information on security, see [Products > Cybersecurity](#). Also see the technical note, [Migrating from SNAP PAC to groov EPIC](#).

You can also add *groov* EPIC as remote I/O in your SNAP PAC System. You get an easy-to-use mobile HMI and IIoT applications including connectivity with enterprise software, cloud services, and legacy PLCs.

- **mistic I/O units**—Control legacy *mistic* I/O units with a SNAP PAC S-series controller and PAC Project Professional.

SNAP PAC SYSTEM ARCHITECTURE

All components work together, no matter what the system's size. When your system needs to expand, investments in development time and field wiring remain largely intact; you simply add more brains and I/O. If new capabilities are required, additional software and controllers can also be added with minimal time and expense.

The next few pages show examples of initial systems and several ways in which they might be expanded.

Example #1: Minimal Initial System

The simplest system consists of just one rack-mounted controller with I/O plus PAC Project Basic™ software. PAC Project Basic includes both control programming (PAC Control) and HMI development (PAC Display). The software is free, and the system includes free product support.

Example #1: Minimal Initial System

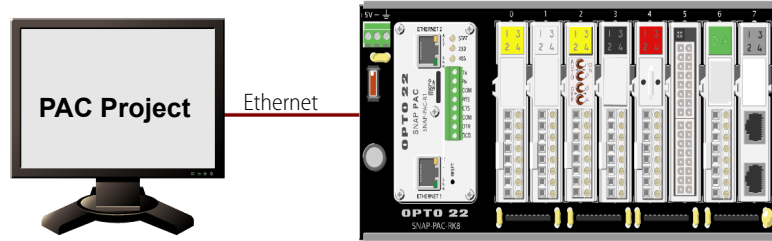

PC for developing PAC Control strategy and running PAC Display HMI

SNAP PAC controller mounted on a rack with I/O. The controller runs the control program independently and provides I/O processing and communication.

SNAP PAC hardware controllers are ready for the IIoT with a built-in RESTful API. See complete information at developer.opto22.com.

Control Programming. You use both flowcharting and scripting (optional) to develop the PAC Control program, or *strategy*, on your PC. You name each I/O point, variable, or other element in the strategy with names that are significant to your application, and the commands you use in the strategy logic are in plain English. With this simplicity, however, you also have advanced functions like subroutines, pointers, and string handling.

After you develop the strategy, you download it to the controller, where it runs independently from the PC to monitor and control the local I/O.

Building the HMI. The database of tags—I/O points, variables, etc.—that you named and described when developing the control strategy in PAC Control is automatically available when you start creating the HMI. You build the HMI using our built-in PAC Display graphics library or imported graphics, and you animate the graphics by simply linking them to tags in the database.

The finished HMI runs on the PC and is used by technicians and operators to monitor the control system, respond to alarms, and so on.

IIoT Ready. All hardware SNAP PACs include an HTTP/HTTPS server and a REST API (representational state transfer application programming interface), with data returned as JSON. So even with just a minimal system you can use your language of choice to securely access I/O point and variable data from the database of tags in the PAC. Your SNAP PAC System arrives ready for the Industrial Internet of Things (IIoT). Requirements: firmware R9.5a or higher and PAC Project R9.5000 or higher. Details at developer.opto22.com.

Example #2: Small Initial System

A small SNAP PAC System might begin with a SNAP PAC rack-mounted controller, a few distributed I/O units, the free PAC Project Basic software, free product support and the built-in RESTful API. To use the REST API, see developer.opto22.com.

Example #2: Small Initial System

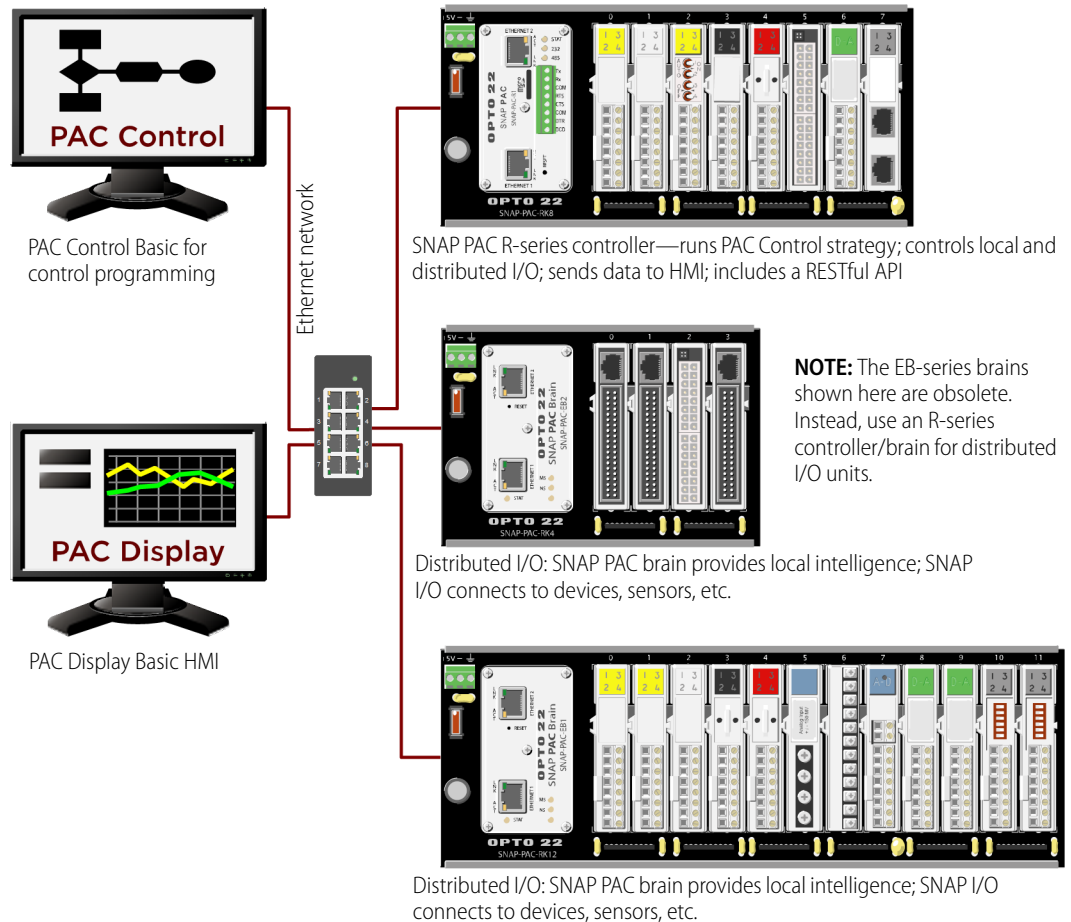

Distributed I/O. The PAC Control strategy runs independently on the controller to monitor and control both the I/O on the controller's rack and the distributed I/O.

Many functions are distributed to the I/O units and handled locally, including latching, counting (up to 20 KHz, depending on the I/O unit processor and I/O module), watchdog timers, thermocouple linearization, offset and gain, ramping, proportional-integral derivative (PID) loop control, and more. This distributed intelligence leaves the main controller free for supervisory tasks, and if communication with the controller is ever lost, these locally handled functions continue without interruption.

Networking. As for networking options, the rack-mounted SNAP PAC R-series controller used for this initial system offers two *independent* Ethernet network interfaces, which can be used to segment the control network from the company network, if desired. SNAP PAC EB brains, if available, include two *switched* Ethernet network interfaces, which means you can choose to daisy-chain the brains together if you want to eliminate or reduce the need for Ethernet routers and switches.

Expanding Your System

When it comes time to scale up, the SNAP PAC System is simple to expand. If you started with the small system discussed above, here are several ways in which you might want to expand. Free product support is included, no matter what the size of your system.

Adding More Distributed I/O

Suppose a new process is added to your manufacturing line, or additional equipment needs monitoring. Simply add the necessary processors and I/O, choosing whatever combination of analog, digital, and serial modules you need at any location. All types of modules can be mixed on the same rack and handled by the same processor.

In your PAC Control strategy, just add the logic necessary to control and monitor the new distributed I/O units, and then download the revised strategy to the controller.

Adding More Distributed I/O

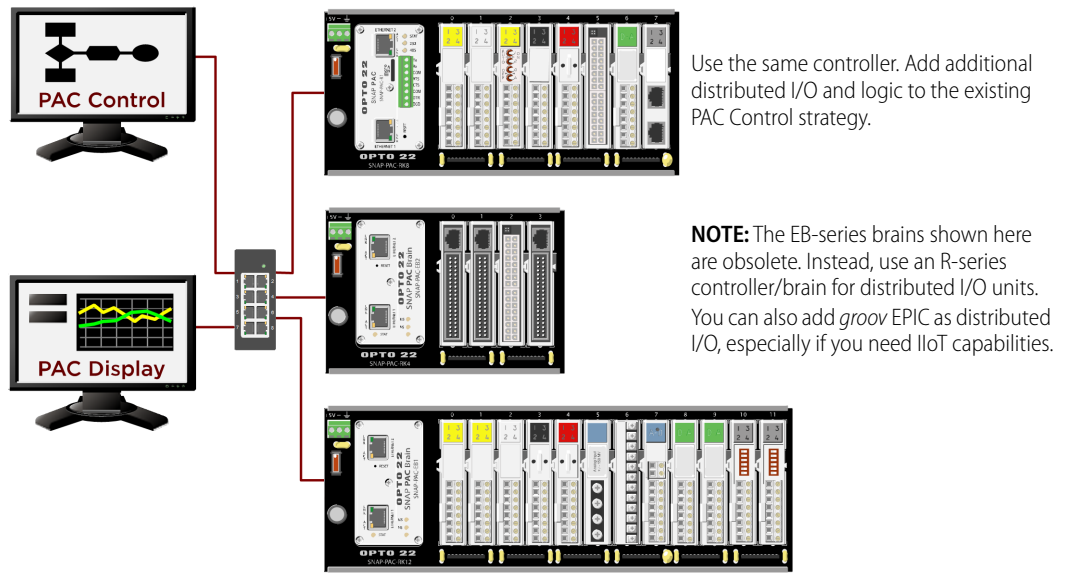

Adding More HMI Seats

Suppose the new process requires additional seats for the HMI, or a second HMI. For multiple PCs running a PAC Display HMI, we strongly recommend purchasing OptoOPCServer. OptoOPCServer is designed for fast, efficient handling of communications between multiple clients and Opto 22 hardware.

Adding More HMI Seats

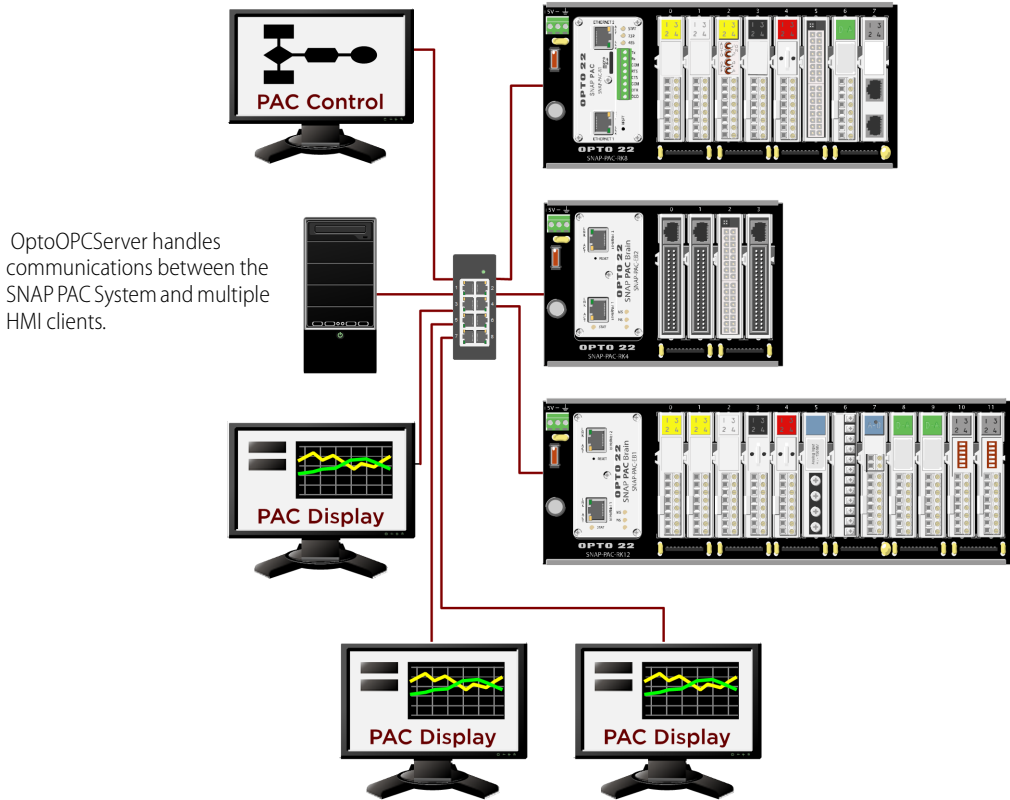

Adding Cybersecurity, IIoT Capabilities, and Mobile Operator Interfaces

To expand your system capabilities now and into the future, consider adding a *groov* EPIC edge programmable industrial controller in front of your SNAP PAC System. *groov* EPIC adds significant **cybersecurity** features, including user authentication and account management, a configurable device firewall, data encryption, security certificate management, and a VPN client.

groov EPIC also adds IIoT capabilities, including MQTT communications, **Ignition Edge**® from Inductive Automation®, and **Node-RED**, making it much easier to share data from your SNAP PAC System with legacy PLCs, company databases, and software and services both on premises and in the cloud.

And if you need to have technicians monitor or control parts of your system from a mobile device, either on premises or remotely, **groov View** is included with a *groov* EPIC processor (also included with *groov* Server for Windows, which runs on a PC). Using *groov* View, you create a simple interface that includes only the data and controls each authorized user needs. You can add other manufacturers' systems and equipment to the same interface, if you wish.

You build your mobile interface in a web browser by dragging and dropping gadgets onto the screen and tagging them, using the same tag database you already have in PAC Control. Then securely view the interface on an iOS or Android smartphone or tablet using the free *groov* View app, or on any device with a web

browser. A *groov* View interface may be the only operator interface you need, or it may supplement your PAC Display or third-party HMI.

Adding Cybersecurity, IIoT Capabilities, and Mobile Operator Interfaces

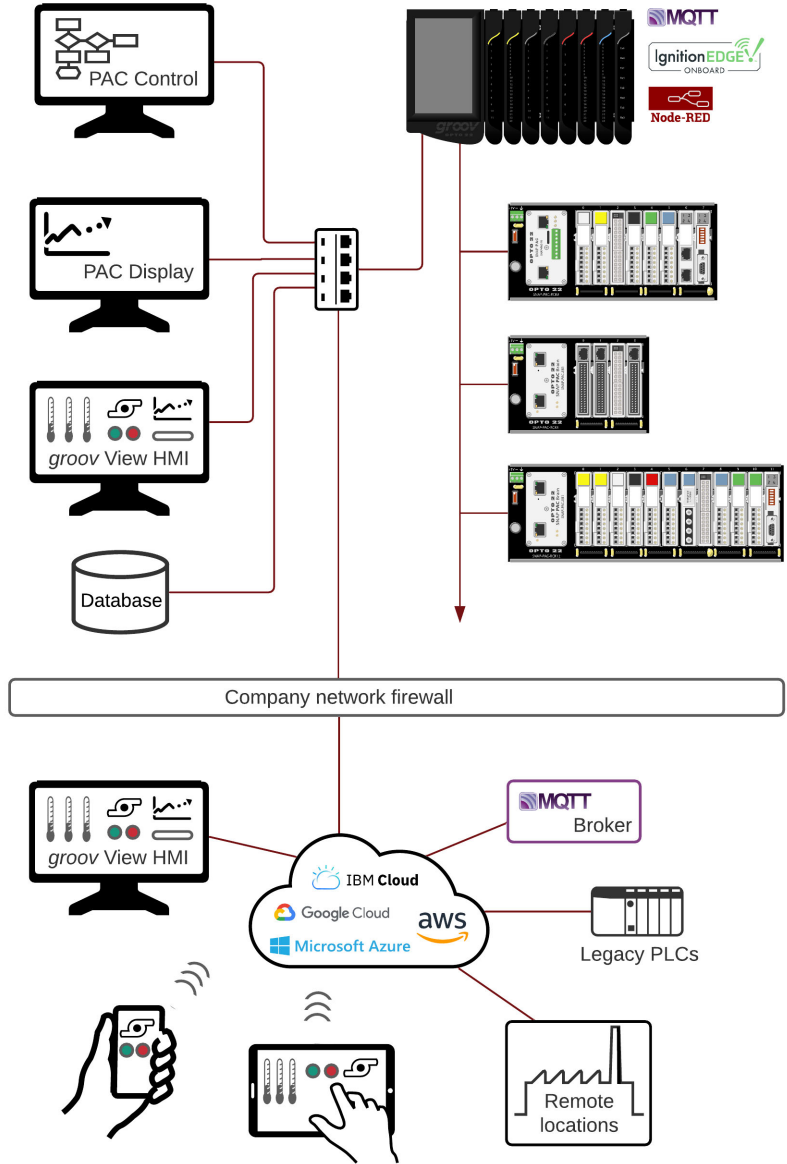

Add a *groov* EPIC processor. Run your PAC Control strategy on EPIC and use your R-series controller as an I/O unit. All SNAP PAC I/O units are compatible with *groov* EPIC.

groov EPIC adds cybersecurity features to help protect your control network. See the [Cybersecurity Technical Note](#).

In addition, *groov* EPIC gives you IIoT capabilities, including MQTT communications, Ignition Edge, and Node-RED.

To build an HMI in *groov* View, use the same tag database you built in PAC Control (or add tags from Modbus/TCP equipment or an OPC UA server) to animate data and control objects in the interface.

The *groov* View interface you build works on PCs, laptops, tablets, and smartphones. Authorized mobile devices can monitor and control from anywhere

Adding Large Numbers of Additional I/O

For very extensive distributed control systems, such as a traditional DCS, you'll want to move up from the rack-mounted R-series controller to a *groov* EPIC processor with IIoT capabilities, a SNAP PAC standalone (S-series) controller, or to SoftPAC for PC-based control. All can run many PAC Control flowcharts at once.

The investments you've already made are not lost. The PAC Control strategy runs on the *groov* EPIC and all SNAP PAC controllers; just add the new I/O points and logic needed. The R-series rack-mounted controller you

replaced can run a separate strategy under the larger controller’s supervision or be used as a brain, since it has the same I/O processing and communication capabilities as a SNAP PAC brain.

Adding Large Numbers of Additional I/O

Add the new I/O points, logic, and variables to the PAC Control strategy. In this image, the SNAP-PAC-S1 controller runs the strategy and controls the entire system. Alternatively, you can use a *groov* EPIC processor, which adds IIoT connectivity, or SoftPAC for PC-based control.

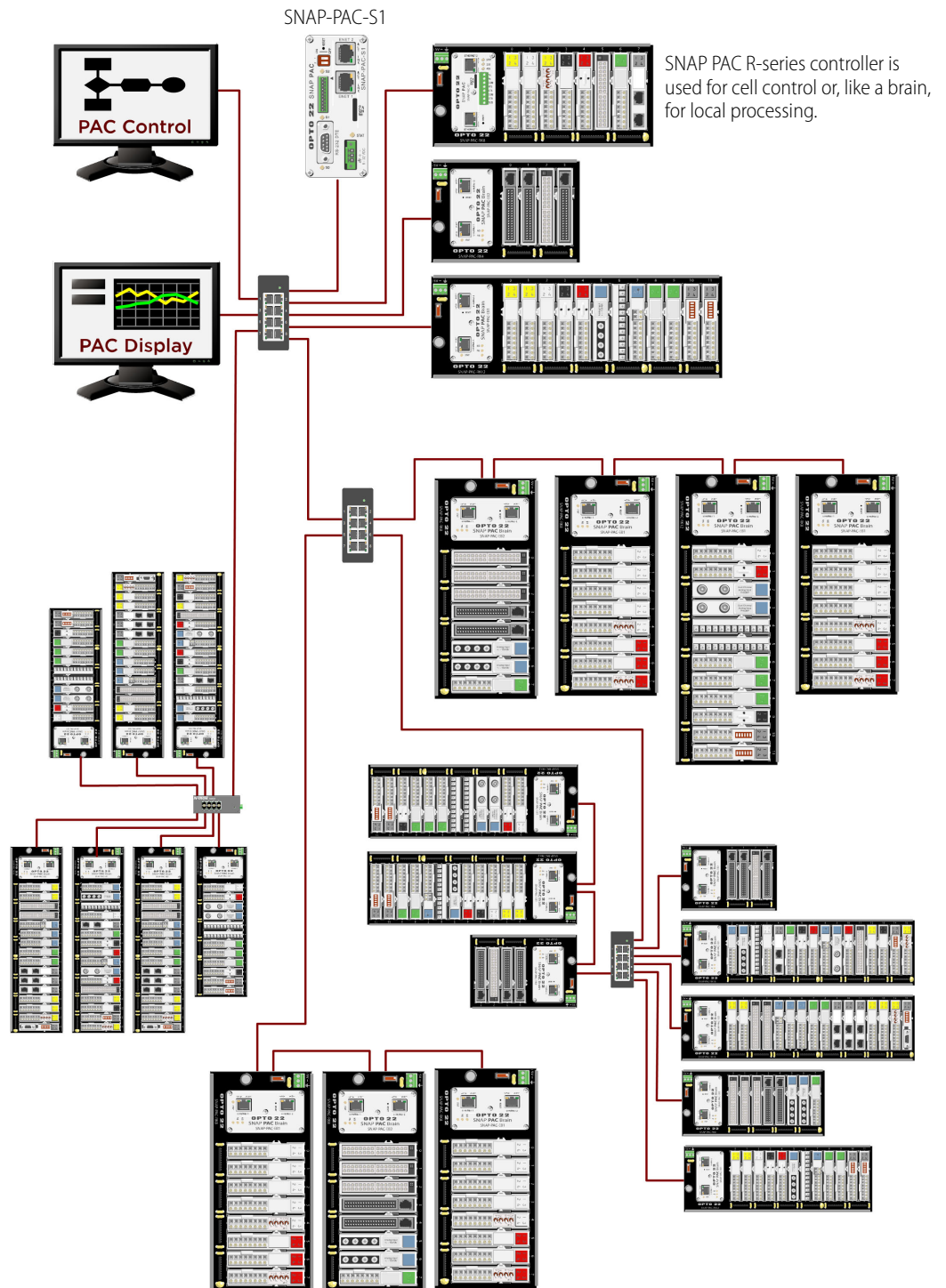

Combining Serial and Ethernet Distributed I/O

If you need to combine both serial and Ethernet distributed I/O in the same system, you can do so easily. A SNAP PAC S-series controller has two independent Ethernet interfaces plus one or more RS-485 serial ports for connections to serial I/O. The SNAP-PAC-S2 controller includes four serial ports, all of which can be software configured for RS-232 or RS-485, as needed.

The PAC Control strategy handles both Ethernet and serial I/O at the same time. Because the same commands and variables apply to I/O on both networks, and the same I/O modules are used on both, no special programming is needed. The same programmed process can control both.

Combining Serial and Ethernet Distributed I/O

The SNAP-PAC-S2 controller runs one PAC Control strategy that manages all distributed I/O—Ethernet and serial.

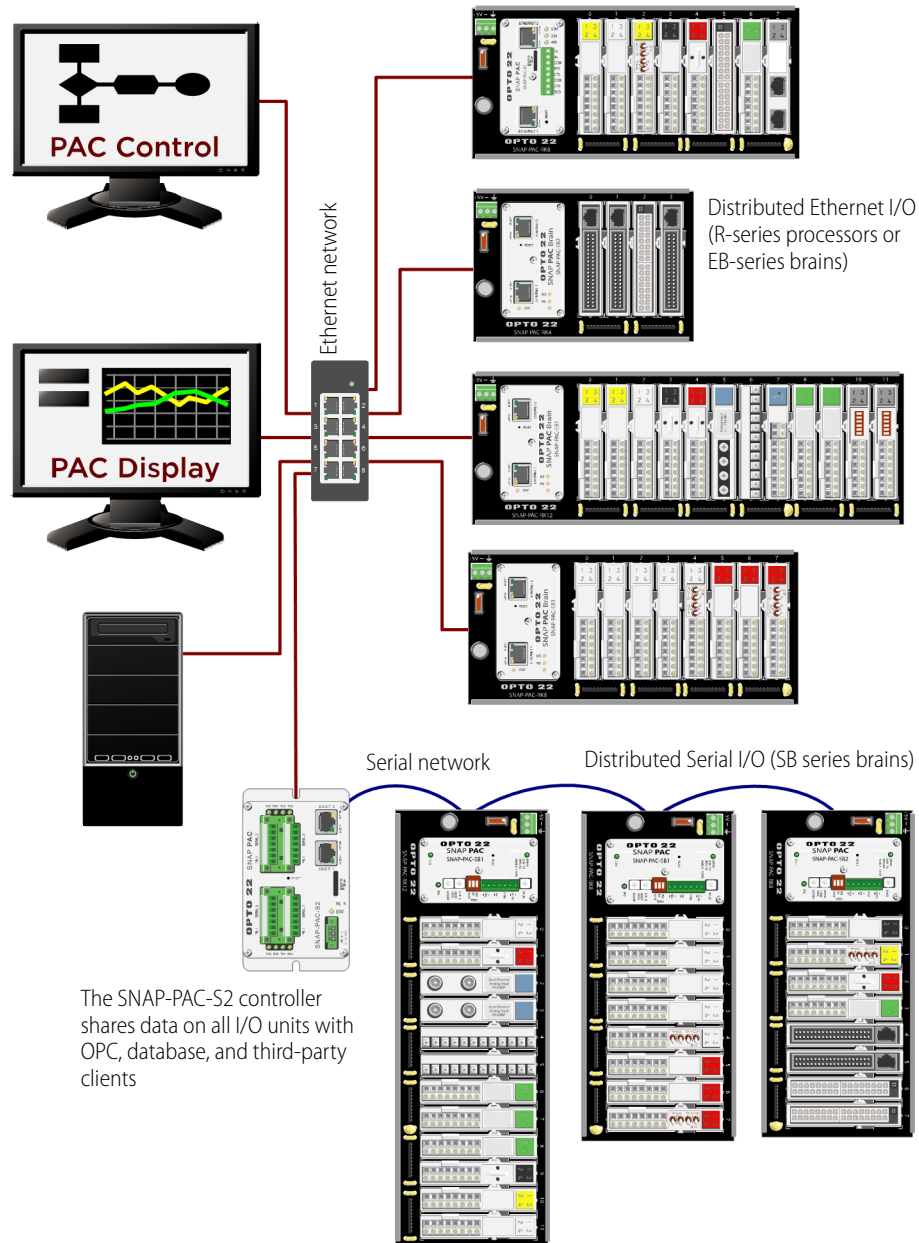

Delivering SNAP PAC System Data to Company Databases

The easiest way to connect to company databases is to purchase a *groov* EPIC processor to use with your SNAP PAC System. In addition to providing distributed I/O or full control for your whole system (still using the PAC Control strategy you've been running), *groov* EPIC easily exchanges data with a variety of on-premises and cloud-based software and services. *groov* EPIC gives you the database connectivity you need now, plus flexibility for future data needs involving other software and devices. [Learn more about *groov* EPIC.](#)

If you prefer, you can purchase OptoDataLink, part of the PAC Project Professional software suite. OptoDataLink can provide data exchange between the SNAP PAC System and popular databases such as Microsoft® SQL Server, Microsoft Access, and MySQL. OptoDataLink uses the same tagname database you developed in PAC Control. You choose data elements from the list and use OptoDataLink's configuration tool to link the data source and the data destination.

Communicating with Third-Party Systems

Communicating with third-party systems is increasingly important for industrial internet of things (IIoT) applications. For greatest flexibility, purchase a *groov* EPIC processor to easily connect with other systems and equipment using Node-RED, MQTT communications, and Ignition or Ignition Edge from Inductive Automation.

Without a *groov* EPIC processor, you still have many ways to communicate.

For **OPC 2.0**-compliant clients, purchase OptoOPCServer (part of the PAC Project Professional software suite). With an efficient multi-threaded engine and report-by-exception method of communicating with clients, OptoOPCServer keeps network traffic on industrial automation and manufacturing networks to a minimum while exchanging data with OPC clients such as Microsoft products, third-party packages, and custom applications you create with tools such as Visual C++.

For **Modbus** systems, SNAP PAC Ethernet-based processors can communicate directly with systems using Modbus/TCP; see the *Modbus/TCP Protocol Guide* (Opto 22 form #1678) for instructions. Or you can download our free integration kits to use Modbus/TCP or serial Modbus with PAC Control.

For **Allen-Bradley** PLC systems such as **CompactLogix**, **ControlLogix**, **MicroLogix 1100/1400**, and **SLC 5/05**, SNAP PAC Ethernet-based processors can communicate directly using the built-in EtherNet/IP protocol. Details are in form #1909, the *IO4AB User's Guide*, and #1770, the *EtherNet/IP for SNAP PAC Protocol Guide*. Step-by-step videos are on our website.

For **Allen-Bradley Data Highway** systems, our free integration kit for PAC Control provides an easy method of communicating with A-B drivers or PLCs that use the DF1 protocol.

A **RESTful API** is built into SNAP PAC S-series and R-series controllers, so you can exchange data easily using the architecture and languages of the Internet. Use your favorite programming language (PHP, .NET, Node.js, Python, or others). Tag data from I/O points and controller variables is returned as JSON. For complete details, see developer.opto22.com.

For more information on the protocols and communication methods available in Opto 22 products, see the [Communication Tools and Protocols Technical Note](#), form 1820.

Communicating with Third-Party Systems

For additional flexibility, consider a *groov* EPIC processor for your SNAP PAC System.

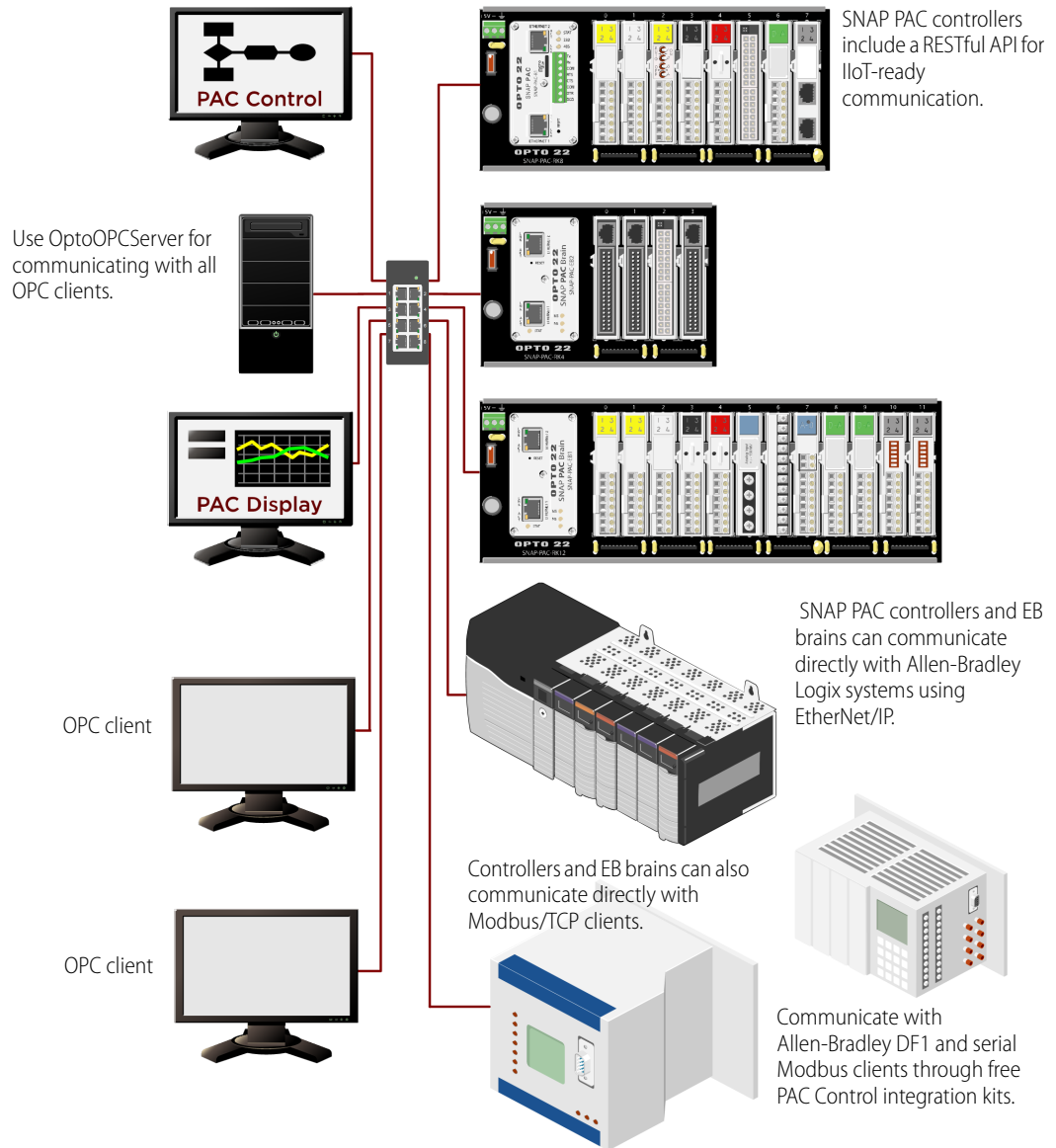

Using Redundant Networking

If you are concerned about the stability of your network links, you'll want to look at redundant networking. Purchase PAC Project Professional™ and use an S-series controller as your main controller, plus R-series controllers for distributed I/O.

Because each S-series and R-series controller has two independent Ethernet network interfaces (two separate IP addresses for each controller), they can be used to create redundant network links. PAC Project Pro adds the software support. For more information, see ["Ethernet Networking Options" on page 46.](#)

Incorporating Legacy Opto 22 Systems

If you've been an Opto 22 customer for several years and need to update older systems or integrate them with newer Ethernet-based systems, the SNAP PAC System provides a good migration path. You'll need PAC Project Professional and a SNAP PAC S-series controller.

PAC Control Professional includes the ability to import legacy OptoControl strategies, and PAC Display Professional can import OptoDisplay projects. PAC Display Pro can also communicate directly with FactoryFloor controllers on the Ethernet network.

SNAP PAC S-series controllers include one or more RS-485 serial ports that support not only serial SNAP PAC SB-series brains but also legacy Opto 22 *mistic* hardware, such as the serial B3000, B3000-BRS, and *mistic* bricks.

Incorporating Legacy Opto 22 Systems

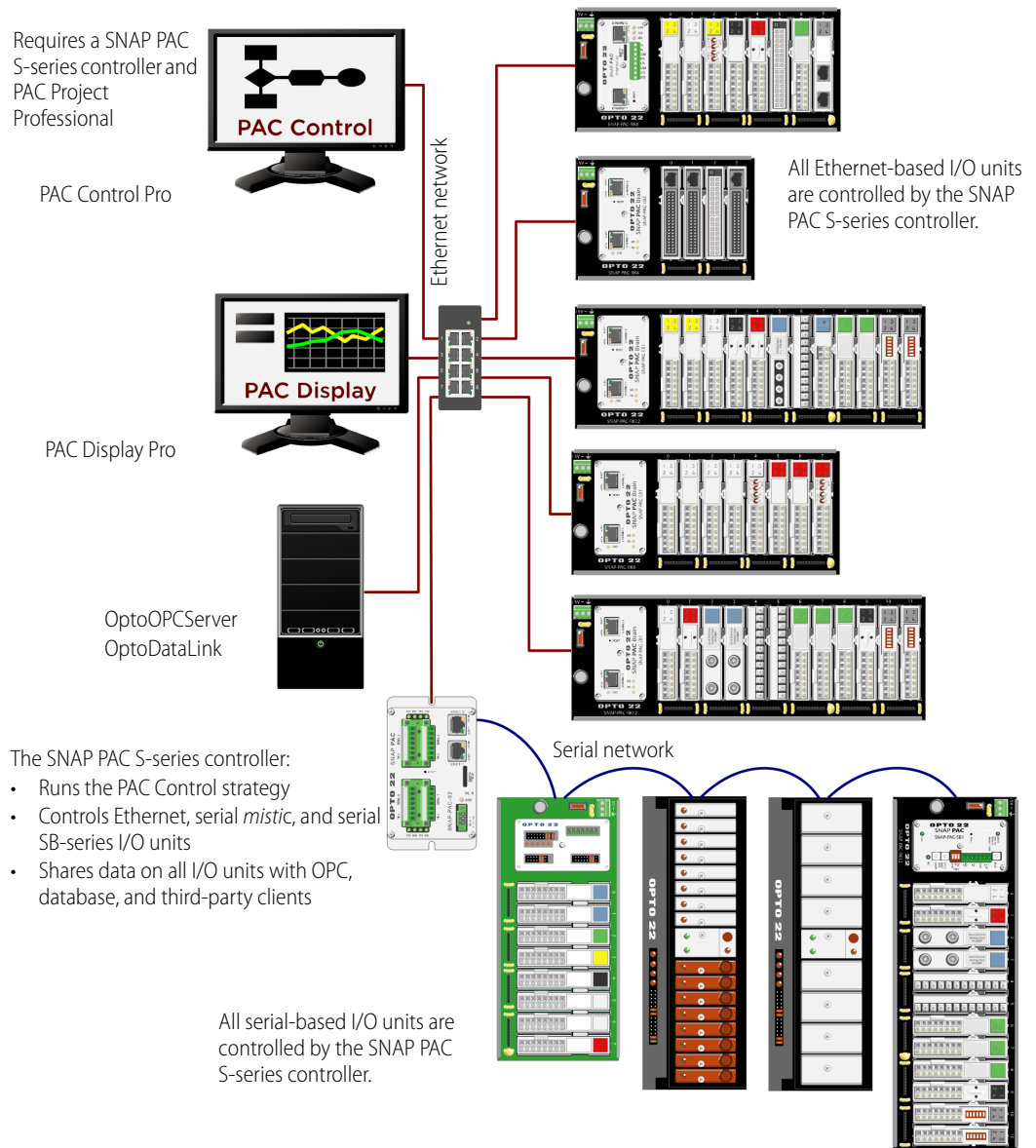

WHAT'S IN THIS GUIDE

This guide describes the SNAP PAC System and its uses and includes specifications and wiring diagrams for the system's four components. This guide assumes that you have some familiarity with TCP/IP and Ethernet networking, and serial networking if you are using serial I/O. If you are not familiar with these subjects, we strongly suggest you consult commercially available resources to learn about them before attempting to install or use the SNAP PAC System.

The following sections are included in this user's guide:

Chapter 1: Introduction—description of the SNAP PAC System architecture, information about related products and documents, and how to reach Opto 22 Product Support.

Chapter 2: Choosing System Components—descriptions and comparison charts for system components, to help you choose which components you need for your system. Additional information can be found in the components' data sheets (see "SNAP PAC System Data Sheets," below).

Chapter 3: Networking Options—explanation and diagrams showing the networking options provided by SNAP PAC processors, including Ethernet network link redundancy, segmented networking, daisy-chaining, and communicating with serial devices and I/O.

Chapter 4: Installing and Wiring System Components—brief instructions for installing SNAP PAC System components and wiring the system to field devices. Additional information may be available in a user's guide for the component (see "SNAP PAC System User's Guides" on page 13).

Appendix A: I/O Specifications—specifications for all SNAP I/O modules: digital, analog, and serial.

Appendix B: Dimensional Diagrams—dimensional diagrams for all SNAP PAC System hardware.

Related Documents

See the following documents for the information shown. Most documents are available for free download on our website, www.opto22.com. The easiest way to find a document is to search on its form number.

For groov EPIC, see the *groov EPIC Processor Data Sheet* (form 2245).

SNAP PAC System Data Sheets

For these products	See this document	Form #
PAC Project Basic and Professional Software Suites	PAC Project Software Suite Data Sheet	1699
OptoOPCServer	OptoOPCServer Data Sheet	1487
OptoDataLink	OptoDataLink Data Sheet	1662
SNAP PAC S-series controllers	SNAP PAC S-Series Controllers Data Sheet	1584
SNAP PAC R-series controllers	SNAP PAC R-Series Controllers Data Sheet	1594
SoftPAC	SoftPAC PC-based Controller Data Sheet	2020
SNAP PAC brains	SNAP PAC Brains Data Sheet	1689
SNAP PAC racks	SNAP PAC Racks Data Sheet	1684
SNAP power supplies	SNAP Power Supplies Data Sheet	1120
SNAP digital input modules (4-channel)	SNAP Digital Input Modules Data Sheet	0773
SNAP digital output modules (4-channel)	SNAP Digital Output Modules Data Sheet	1144
SNAP mechanical power relay output modules	SNAP Mechanical Power Relay Output Module Data Sheet	1967
SNAP high-density digital modules (more than 4 channels)	SNAP High-Density Digital I/O Modules Data Sheet	1556

For these products	See this document	Form #
SNAP analog input modules	SNAP Analog Input Modules Data Sheet	1065
SNAP analog input modules with channel-to-channel isolation	SNAP Isolated Analog Input Modules Data Sheet	1182
SNAP analog output modules	SNAP Analog Output Modules Data Sheet	1066
SNAP quadrature module	SNAP Quadrature Input Module Data Sheet	1053
SNAP load cell modules	SNAP Load Cell Modules Data Sheet	1590
SNAP serial communication modules	SNAP Serial Communication Modules Data Sheet	1184
SNAP stepper motor module	SNAP-SCM-ST2 Pulse Output Module Data Sheet	1944
SNAP Controller Area Network (CAN) module	SNAP-SCM-CAN2B Communication Module Data Sheet	1537
SNAP TEX cables & breakout boards	SNAP TEX Cables & Breakout Boards Data Sheet	1756
SNAP TEX DIN-rail kits, spare parts, and tools for mounting and wiring	SNAP TEX Mounting/Wiring Tools and Spare Parts Data Sheet	1772

SNAP PAC System User's Guides

For these products or uses	See this document	Form #
Develop PAC Control programs (strategies)	PAC Control User's Guide	1700
	PAC Control Command Reference	1701
	PAC Control Commands Quick Reference	1703
Build PAC Display HMIs	PAC Display User's Guide	1702
Build <i>groov</i> View mobile operator interfaces	<i>groov</i> View User's Guide	2027
Assign IP addresses, configure hardware	PAC Manager User's Guide	1704
Communicate with OPC clients	OptoOPCServer User's Guide	1439
Exchange data with company databases	OptoDataLink User's Guide	1705
Install/use SNAP PAC S-series controllers	SNAP PAC S-Series Controller User's Guide	1592
Install/use SNAP PAC R-series controllers	SNAP PAC R-Series Controller User's Guide	1595
Install/use SNAP PAC brains	SNAP PAC Brain User's Guide	1690
Write custom applications for SNAP PAC controllers and brains	OptoMMP Protocol Guide	1465
	Modbus/TCP Protocol Guide	1678
Communicate with Modbus systems	Modbus/Serial Integration Kit for PAC Project	1660
	Modbus/TCP Integration Kit for PAC Project	1644
	IO4AB User's Guide	1909
Communicate with Allen-Bradley systems	EtherNet/IP for SNAP PAC Protocol Guide	1770
	Allen-Bradley DF1 Integration Kit For PAC Control	1706
	SNAP High-Density Digital I/O Modules User's Guide	1547
Install/use SNAP high-density digital modules (more than 4 channels)		
Communicate with serial devices	SNAP Serial Communication Module User's Guide	1191

Other Useful SNAP PAC System Documents

For this purpose	See this document	Form #
Using the RESTful API in hardware PACs	developer.opto22.com	--
Comparing programmable automation controllers to PLCs	Understanding Programmable Automation Controllers (PACs) in Industrial Automation (<i>white paper</i>)	1634
Learning how to approach a PAC Project or groov View application	Opto 22 Best Practices Technical Note	2073
Designing operator interfaces	Building an HMI that Works: New Best Practices for Operator Interface Design	2061
Networking the SNAP PAC System	Guide to Networking SNAP PAC Products	1796
Integrating SNAP PAC System hardware and software with older Opto 22 systems	SNAP PAC System Migration Technical Note	1688
	FactoryFloor to PAC Project Migration Technical Note	1692
	Legacy and Current SNAP Product Comparison Charts	1693
	PAC Control User's Guide, Legacy Edition	1710
	PAC Control Command Reference, Legacy Edition	1711
	PAC Control Commands Quick Reference, Legacy Ed.	1713
	PAC Display User's Guide, Legacy Edition	1712
	PAC Manager User's Guide, Legacy Edition	1714

FOR HELP

For sales or service, give us a call or email us. We're happy to help. Pre-sales engineering and product support are both free.

Sales

Here's how to purchase SNAP PAC System components:

- Contact one of our worldwide distributors (a list of distributors is on our website, www.opto22.com; under the About Us tab, click Distributors).
- Visit our website (www.opto22.com) and click the Products tab to order online (available in the U.S. and Canada only).
- Contact Opto 22 Sales: 1-800-321-6786 or 1-951-695-3000 (email: sales@opto22.com).

For help configuring a system or for technical information on Opto 22 products, contact an Opto 22 pre-sales engineer:

Phone (toll-free in the U.S and Canada): 1-800-321-6786
(Local, or outside the U.S. and Canada): +1-951-695-3000

Web chat or contact: [Contact us webpage](#)

Email: systemseng@opto22.com

Product Support

If you have problems installing or using the SNAP PAC System and cannot find the help you need in this guide or the related guides on our website, contact Opto 22 Product Support.

Phone: 800-TEK-OPTO
(800-835-6786 toll-free in the U.S. and Canada)

951-695-3080
Monday through Friday,
7 a.m. to 5 p.m. Pacific Time

Email: support@opto22.com

Opto 22 website: www.opto22.com

When calling for technical support, you can help us help you *faster* if you provide the following information to the Product Support engineer:

- A screen capture of the Help > About dialog box showing software product and version (available by clicking Help > About in the application's menu bar).
- Opto 22 hardware part numbers or models that you're working with.
- Firmware version:
 - For *groov* EPIC processors and *groov* RIO modules: available in *groov* Manage by clicking Info and Help > About.
 - For SNAP controllers and brains: available in PAC Manager by clicking Tools > Inspect.
- Specific error messages you received.
- Version of your computer's operating system.
- For PAC Control, PAC Display, OptoOPCServer, or PAC Manager, you may be requested to provide additional information, such as log or dump files. You can find these files in a support files sub-folder:
 - a.** On your Windows Desktop, double-click the PAC Project 10.4 folder.
 - b.** Double-click Support Files.
 - c.** Double-click on the appropriate shortcut to open the sub-folder containing the requested files.

Note: *PAC Control, PAC Display, OptoOPCServer, and PAC Manager create appropriate sub-folders when they create diagnostic log or dump files. If they have not created these files, the sub-folder may not exist; in this case, the shortcut will not work.*

FOR HELP

2: Choosing System Components

INTRODUCTION

This chapter helps you choose the components needed for your application. It describes system components and compares products.

As described in the first chapter, the SNAP PAC System consists of four integrated components:

- Software—see [page 19](#)
- Controllers—see [page 21](#)
- I/O processors (brains or controllers)—see [page 23](#)
- I/O—see [page 26](#). (For more detailed information, also see [Appendix A: I/O Specifications](#) for input/output module specifications.)

The following accessories for your system may also be useful:

- Power supplies—[page 33](#)
- Wiring and mounting accessories for easier field wiring—[page 36](#)

BUILDING A SNAP PAC SYSTEM

With a few choices, summarized in the diagram on the following page, you can build a SNAP PAC System to do just what you need.

Steps to Build a SNAP PAC System

Step 1: Choose software



PAC Project Basic

- PAC Control Basic
- PAC Display Basic
- PAC Manager
- PAC Utilities

PAC Project Professional

- PAC Control Professional
- PAC Display Professional
- PAC Manager
- PAC Utilities
- OptoOPCServer
- OptoDataLink
- SoftPAC

Step 2: Choose controller

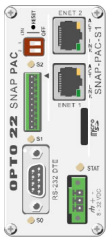

SNAP PAC S-series

- Standalone
- Dual independent Ethernet interfaces; multiple serial ports
- Secure server/RESTful API
- Large distributed systems
- *mistic* serial support (with PAC Project Pro)
- Controller redundancy (with PAC Project Pro and option kit)

SNAP PAC R-series

- Rack mounted (see racks below)
- Dual independent Ethernet interfaces
- Secure server/RESTful API
- I/O processor and communications built in
- Analog, digital, and serial I/O
- R1 includes high-speed digital functions

SoftPAC

- PC-based control in a Microsoft® Windows® environment
- Uses a PC's fast read and write capabilities and its greater space for data storage
- Compatible with SNAP Ethernet-based I/O units
- Communicates peer-to-peer with any SNAP PAC S-series or R-series controller on the network

Step 3: Choose I/O processors



Ethernet: SNAP-PAC-R1 or SNAP-PAC-R2 controllers

NOTE: SNAP-PAC-EB1 and SNAP-PAC-EB2 brains are obsolete as of 2022. Use R-series controller instead.

- Analog, digital, and serial I/O
- R1 includes high-speed digital functions
- Also offer local control if needed

Serial: SNAP-PAC-SB1 or SNAP-PAC-SB2 brains

- Analog and digital I/O
- SB1 includes high-speed digital functions

Step 4: Choose I/O

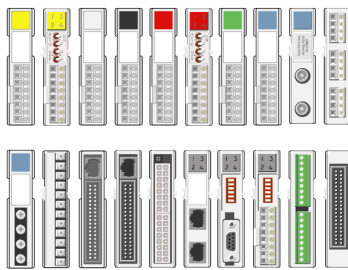

Choose from **all SNAP I/O modules**, a wide selection of analog, digital, and serial modules.

Brain or rack-mounted controller and modules snap onto **SNAP PAC racks**.

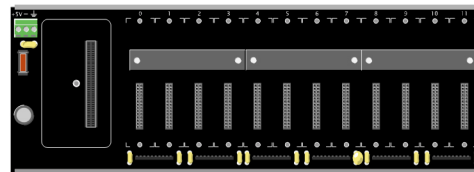

- SNAP-PAC-RCK4 (4 modules)
- SNAP-PAC-RCK8 (8 modules)
- SNAP-PAC-RCK12 (12 modules)
- SNAP-PAC-RCK16 (16 modules)

CHOOSING SOFTWARE

For software, choose between two forms of the PAC Project Software Suite: PAC Project Basic and PAC Project Professional.

PAC Project Basic is free and can be downloaded from [our website \(www.opto22.com\)](http://www.opto22.com). PAC Project Basic includes everything you need for most control and monitoring applications: control programming, HMI creation, and I/O configuration software.

PAC Project Professional is available for purchase. The Pro version adds OPC communication, database connectivity, and support for both Ethernet link redundancy and controller redundancy. Legacy hardware is also supported, with a SNAP PAC S-series controller.

Both PAC Project Basic and PAC Project Pro include the following:

- **PAC Control**, for developing control applications to run on an Opto 22 SNAP PAC controller
- **PAC Display**, for developing human-machine interface applications (HMIs) for technicians and operators
- **PAC Manager**, for configuring and inspecting Opto 22 SNAP PAC controllers, brains, and I/O

In addition, PAC Project Professional adds:

- **OptoOPCServer**, for OLE for Process Control (OPC) communication with OPC 2.0 clients
- **OptoDataLink**, for sharing SNAP PAC System data with ODBC-compliant databases
- **SoftPAC**, for running control programs on a software-based programmable automation controller (PAC) designed for PC-based control. SoftPAC can also be purchased separately. (See [page 21](#) for more information.)

All of these software applications run on 32-bit and 64-bit versions of Microsoft® Windows® 10 Professional.

Individual software components of PAC Project Pro are also available for separate purchase. For example, if you need OPC connectivity but not the other Pro features, you can use PAC Project Basic and purchase only OptoOPCServer.

The comparison chart below details the differences between PAC Project Basic and PAC Project Pro.

PAC Project Basic and Professional Comparison Chart

The following table compares the features in version R10.3 of PAC Project Basic™ and PAC Project Professional™.

Feature		Basic	Pro
Included software	PAC Control™ Basic	●	●
	PAC Control Professional		●
	PAC Display™ Basic	●	●
	PAC Display Professional		●
	PAC Manager™	●	●
	OptoOPCServer™		●
	OptoDataLink™		●
	SoftPAC™		●
Control software: PAC Control			
Compatible controllers	groov EPIC processor	●	●
	SNAP PAC controllers (S-series and R-series)	●	●
	SoftPAC software-based controller	●	●

Feature		Basic	Pro
Compatible I/O	Built-in I/O unit (in <i>groov</i> EPIC processors and SNAP PAC R-series controllers)	●	●
	<i>groov</i> RIO modules (with <i>groov</i> EPIC and SNAP PAC controllers) ¹	●	●
	SNAP PAC brains	●	●
	G4EB2 brains (with <i>groov</i> EPIC and SNAP PAC controllers)	●	●
	Ethernet I/O units—E1, E2, EIO, UIO (with <i>groov</i> EPIC and SNAP PAC controllers)	●	●
	Serial <i>mistic</i> [™] brains/bricks: B3000-B, B3000, SNAP-BRS, B100, B200, G4D16R, G4D32RS, G4A8R (with SNAP PAC S-series controllers only)		●
Network	<i>Controller to PC: groov</i> EPIC and SNAP PAC—Ethernet	●	●
	<i>Controller to I/O:</i>		
	• <i>groov</i> EPIC—Ethernet only	●	●
	• SNAP PAC S-series:	●	●
	– Ethernet to R-series controllers and EB brains	●	●
	– Serial to SB brains	●	●
	– Serial to <i>mistic</i> brains		●
	• SNAP PAC R-series—Ethernet only	●	●
<i>Controller to third-party devices:</i> Ethernet or serial ³	●	●	
Support for Ethernet link redundancy or segmented control network		●	
[Obsolete as of 2022] Support for controller redundancy (SNAP PAC S-series only) ⁴		●	
Main features	Flowchart programming	●	●
	OptoScript programming	●	●
	Subroutines (debuggable)	●	●
	Graphical debugger	●	●
	Conversion utility for OptoControl 4.1 strategies		●
	Support for serial <i>mistic</i> I/O units ²		●
	Ethernet link redundancy (with S-series controllers and R-series I/O units)		●
Maximum charts running at once	On <i>groov</i> EPIC (plus host task)	64	64
	On SoftPAC (plus host task)	64	64
	On SNAP PAC S-series (plus host task)	32	32
	On SNAP PAC R-series (plus host task)	16	16
Proportional-integral-derivative (PID) loops	PID algorithms for Ethernet I/O units	4	4
	PID algorithm for <i>mistic</i> serial units ²	–	1
	Loops per SNAP PAC rack-mounted controller or brain	96	96
	Loops per <i>groov</i> RIO module	4	4
	Loops per <i>mistic</i> brain/brick ²	–	8
	Graphical tuner for Ethernet PID loops	●	●
	Graphical tuner for <i>mistic</i> ² PID loops		●
Ethernet link redundancy	Primary and secondary IP addresses on <i>groov</i> EPIC processors and SNAP PAC controllers		●
	PAC Control commands can be used to control redundancy algorithm		●
Controller redundancy ⁴ [Required hardware obsolete as of 2022.]	PAC Redundancy Manager utility		●
	Checkpoint blocks		●

Feature		Basic	Pro
Additional toolkits ⁵	Modbus Integration Kit (serial and TCP)	●	●
	Controller Area Network (CAN) Integration Kit ⁶	●	●
	Other Integration Kits (BACnet, TL1, DNP3, IEC60870-5, Allen-Bradley DF1) ⁶	●	●
HMI software: PAC Display			
Main features	Alarming	●	●
	Trending	●	●
	Logging	●	●
	Operator authentication and login	●	●
	3000-graphic library	●	●
	Additional graphics tools for PID and embedding web pages		●
	Data logging to MySQL, Microsoft [®] SQL Server, and other ODBC databases		●
	Conversion utility for OptoDisplay projects		●
	Primary and secondary IP addresses for control engine		●
	Primary and secondary scanner		●
Controllers supported	<i>groov</i> EPIC processors ⁷	●	●
	SNAP PAC controllers	●	●
	ioControl controllers	●	●
	OptoControl controllers with Ethernet interface		●
OPC server: OptoOPCServer⁸			
OPC version	OPC DA 2.0-compliant ⁸		●
Database connectivity: OptoDataLink⁹			
Databases supported	Microsoft SQL Server, Microsoft Access, MySQL, and ODBC-compatible databases		●
PC-based control: SoftPAC			
Compatible I/O	<i>groov</i> RIO modules	●	●
	<i>groov</i> I/O (EPIC processor)	●	●
	SNAP PAC (R-series and EB-series)	●	●
	Ethernet I/O units (E1, E2, UIO, EIO)	●	●
	G4EB2 brains	●	●

1 Requires SNAP PAC controller firmware 10.3a or higher or *groov* EPIC firmware 2.0.0 or higher.

2 Requires SNAP PAC S-series controller(s).

3 On a *groov* EPIC, serial connections from the processor require a USB-to-serial adapter.

4 The required [SNAP-PAC-ROK](#) Redundancy Option Kit is obsolete as of 2022.

5 For more information, see the [Communication Tools & Protocols for Opto 22 Products Technical Note](#) (form 1820).

6 Not recommended for use with *groov* EPIC processors running PAC Control.

7 PAC Display projects can include *groov* EPIC systems and *groov* RIO modules. PAC Display cannot run on an EPIC processor; it runs on a Microsoft Windows PC.

8 For an OPC UA-compliant server, use a *groov* EPIC processor.

9 Do not use OptoDataLink with a *groov* EPIC processor; use its included data communication options instead.

CHOOSING CONTROLLERS

For controllers, choose from rack-mounted (R-series) or standalone (S-series) SNAP PAC industrially hardened programmable automation controllers, or choose software-based SoftPAC for PC-based control.

SNAP PAC R-series controllers mount right on the rack with SNAP I/O modules, and the controller includes I/O processing as well as control functions. Essentially, it is a controller and a brain in one package. The R-series is ideal for cell control or less complex distributed systems. The R-series is IIoT and developer ready with an included RESTful API (minimum firmware R9.5a and PAC Project R9.5000).

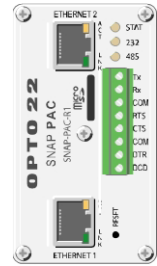

Choose the *SNAP-PAC-R1* if you need high-speed digital functions. Choose the *SNAP-PAC-R2* if you don't need high-speed digital. Otherwise, the two R-series controllers are identical. A Factory Mutual-approved version of the R1 controller is available; its part number is *SNAP-PAC-R1-FM*. This FM model also meets ATEX standards. One model, the *SNAP-PAC-R1-B*, is used for upgrading older I/O units; it fits on a legacy SNAP B-series rack instead of a SNAP PAC rack. SNAP-PAC-R1-B is also FM approved and meets ATEX standards.

SNAP PAC S-series controllers are standalone industrial controllers suitable for any size system, even as large or complex as a traditional DCS. S-series controllers include a RESTful API for secure, easy access to data for your IIoT application or developer use (minimum firmware R9.5a and PAC Project R9.5000).

S-series controllers are more powerful than the R-series and can run twice as many PAC Control flowcharts simultaneously.

Use S-series controllers if you have serial I/O:

- The *SNAP-PAC-S1* has three serial ports: one RS-485 for serial I/O, one RS-232 for modem/PPP use, and one RS-232 for other serial devices.
- The *SNAP-PAC-S2* has four flexible serial ports, all software configurable for RS-485 or RS-232.

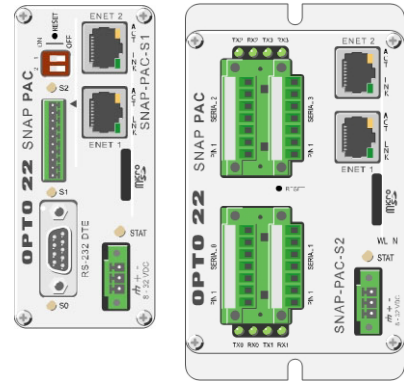

Used with PAC Project Professional, S-series controllers offer additional options. They can be used for network link redundancy (see [page 46](#)). They also offer a migration path for customers with legacy serial *mistic* I/O units, as they can communicate with and control this older hardware using PAC Project Professional.

Both S-series and R-series controllers carry a 30-month warranty from date of manufacture.

For a detailed comparison of SNAP PAC R-series and S-series controller features, see the [“SNAP PAC Controller and Brain Comparison Chart” on page 23](#).

SoftPAC™ is a software-based programmable automation controller (PAC) designed for PC-based control. SoftPAC gives you the choice of running your control program in a Microsoft Windows environment rather than on a standalone or rack-mounted PAC.



SoftPAC is ideal for machine builders or OEMs who may already have a PC in their product. SoftPAC can provide significant savings in hardware costs for some applications.

SoftPAC is for Ethernet-based communication only; it does not support serial I/O units and cannot communicate through serial ports within the PC. However, SoftPAC does support SNAP serial modules on I/O racks.

SoftPAC is especially useful for applications requiring extended file storage, frequent access to files, math-intensive processes, or a large number of control flowcharts running at the same time. For example, industrial engineers working with gas density calculations, solar tracking, and encryption can greatly reduce calculation time.

CHOOSING BRAINS

For distributed I/O, choose among four SNAP PAC I/O processors, depending on whether you need Ethernet or serial connections and whether your application requires high-speed digital functions.

Ethernet

NOTE: As of 2022 and due to the unavailability of essential parts, SNAP-PAC-EB1 and SNAP-PAC-EB2 brains are obsolete. Instead, use SNAP-PAC-R1 and SNAP-PAC-R2 controllers as I/O processors.

Both R-series controllers provide processing for SNAP analog, serial, 4-channel digital, and high-density digital I/O modules. They also include PID loop control (up to 96 loops per brain) and several communication capabilities, including Modbus/TCP, SNMP (Simple Network Management Protocol), SMTP (email), and FTP (File Transfer Protocol). Both have a 30-month warranty from date of manufacture.

Note that R-series controllers have two *independent* Ethernet network interfaces. In contrast, all obsolete EB brains had two *switched* Ethernet network interfaces. Switched interfaces act like a network switch, which means you could connect them in a daisy-chain configuration. You cannot daisy-chain R-series controllers.

Serial Brains

The *SNAP-PAC-SB1* offers high-speed counting (up to 20 KHz), quadrature counting, digital time-proportional output (TPO), and pulse generation and measurement. The *SNAP-PAC-SB2* does not include high-speed digital functions.

Both SB brains provide processing for SNAP analog, 4-channel digital, and high-density digital I/O modules. They also include PID loop control (up to 96 loops per brain). SB brains communicate over an RS-485 2-wire or 4-wire serial link, with baud rates from 300 baud to 230.4 Kbaud. Both brains carry a 30-month warranty.

Comparing SNAP PAC Controllers and Brains

Many I/O and communication features of SNAP PAC brains overlap with R-series controllers, but there are also some significant differences. We've put all the SNAP PAC controllers and brains into the comparison chart below, so you can choose the processors you need more easily.

SNAP PAC CONTROLLER AND BRAIN COMPARISON CHART

This table compares SNAP PAC controllers and brains using PAC firmware R10.0 and PAC Project R10.0 software (or higher). Shaded part numbers are obsolete as of 2022; use rack-mounted controllers in place of Ethernet brains.

FEATURE		SNAP PAC Controllers						SNAP PAC Brains			
		SoftPAC	Standalone		Rack-mounted			Ethernet		Serial	
			SNAP-PAC-S1	SNAP-PAC-S2	SNAP-PAC-R1	SNAP-PAC-R1-B	SNAP-PAC-R2	SNAP-PAC-EB1 SNAP-PAC-EB1-FM	SNAP-PAC-EB2 SNAP-PAC-EB2-FM	SNAP-PAC-SB1	SNAP-PAC-SB2
Runs PAC Control strategies		●	●	●	●	●	●				
Maximum PAC Control charts running at once (plus host task)		64	32	32	16	16	16				
Communication	Two independent Ethernet network interfaces (two IP addresses)	a	●	●	●	●	●				
	Two switched Ethernet network interfaces (one IP address) for multi-drop configuration							●	●		
	Total number of RS-232 serial ports	b	2	4 ^c	1	1	1	0	0	0	0
	Total number of RS-485 serial ports	b	1	4 ^c	0	0	0	0	0	1	1

SNAP PAC CONTROLLER AND BRAIN COMPARISON CHART

FEATURE		SNAP PAC Controllers						SNAP PAC Brains			
		SW	Standalone		Rack-mounted			Ethernet		Serial	
			SoftPAC	SNAP-PAC-S1 SNAP-PAC-S1-FM	SNAP-PAC-S2	SNAP-PAC-R1 SNAP-PAC-R1-FM	SNAP-PAC-R1-B	SNAP-PAC-R2	SNAP-PAC-EB1 SNAP-PAC-EB1-FM	SNAP-PAC-EB2 SNAP-PAC-EB2-FM	SNAP-PAC-SB1
Protocols	TCP/IP, UDP/IP	●	●	●	●	●	●	●	●		
	EtherNet/IP™ (Allen-Bradley® RSLogix® systems and others)		●	●	●	●	●	●	●		
	Modbus®/TCP (slave) ^d		●	●	●	●	●	●	●		
	OPC driver support	●	●	●	●	●	●	●	●	● ^f	● ^f
	RESTful API		●	●	●	●	●				
	HTTP/HTTPS		●	●	●	●	●				
	OptoMMP memory-mapped protocol	● ^g	●	●	●	●	●	●	●	●	●
	SNMP (network management)		●	●	●	●	●	●	●		
	FTP server, file system		●	●	●	●	●	●	●		
	FTP client	●	●	●	●	●	●				
SMTP (email client with authentication and attachments)	●	●	●	●	●	●					
SNAP-PAC nodes for Node-RED; RESTful API			●	●	●	●	●				
Direct access to hard drive & network drives (Dropbox®, etc.)		●									
Realtime clock		a	●	●	●	●	●	●	●	●	●
Backup battery (recharges when brain has power) ^h			●	●	●	●	●	●	●	●	●
Physical RAM (MB)		a	32		16			16		16	
RAM available for Strategy (MB)		64	16		4			--		--	
Battery-backed RAM (MB)		8	8		2			--		--	
Flash memory (MB)		i	16		8			8		8	
Removable data storage (microSD card slot)		a	32 GB max. ^k		32 GB max. ^k						
32-bit processor		a	●	●	●	●	●	●	●	●	●
Floating-point unit (FPU)		a	●	●	●	●	●				
Power requirements		a	8–32 VDC ^l 10 W–11.3 W max		5.0 to 5.2 VDC @ 1.2–1.5 A			5.0 to 5.2 VDC @ 750 mA–1.0 A		5.0 to 5.2 VDC @ 750 mA–1.0 A	
Operating Temperature in degrees C		a	-20 to 60		-20 to 60			-20 to 60		-20 to 60	
Storage Temperature in degrees C			-40 to 85		-40 to 85			-40 to 85		-40 to 85	
Humidity (non-condensing)		a	0–95%		0–95%			0–95%		0–95%	
Compatible I/O units ⁿ	SNAP PAC EB brains	●	●	●	●	●	●				
	SNAP PAC SB brains		●	●							
	SNAP PAC R-series controllers	●	●	●	●	●	●				
	groov EPIC processors	●	●	●	●	●	●				
	groov RIO modules	●	●	●	●	●	●				
Combination controller and I/O processor					●	●	●				
Mounts on SNAP PAC I/O mounting rack		n/a	n/a		●		●	●	●	●	●
Mounts on SNAP B-series I/O mounting rack		n/a	n/a			●					
Maximum number of modules allowed on largest rack: Any mix of 16 digital, 16 analog, and 8 serial		n/a	n/a		● ^o	● ^o	●	●	●	● ^p	● ^p

FEATURE		SNAP PAC Controllers						SNAP PAC Brains			
		SW	Standalone		Rack-mounted			Ethernet		Serial	
		SoftPAC	SNAP-PAC-S1 SNAP-PAC-S1-FM	SNAP-PAC-S2	SNAP-PAC-R1 SNAP-PAC-R1-FM	SNAP-PAC-R1-B	SNAP-PAC-R2	SNAP-PAC-EB1 SNAP-PAC-EB1-FM	SNAP-PAC-EB2 SNAP-PAC-EB2-FM	SNAP-PAC-SB1	SNAP-PAC-SB2
Digital I/O point features	Input latching	n/a	n/a		●	●	●	●	●	●	●
	On/off status				●	●	●	●	●	●	●
	Watchdog timer				●	●	●	●	●	●	●
	High-speed counting (up to 20 kHz) ^q				●	●		●		●	
	Quadrature counting ^r				●	●		●		●	
	On-pulse & off-pulse measurement ^d				●	●		●		●	
	Frequency & Period measurement ^d				●	●		●		●	
	TPO (time-proportional output)				●	●	●	●	●	●	●
	Digital totalizing ^q				●	●	●	●	●	●	●
	Pulse generation (continuous square wave, N pulses, on-pulse, off-pulse)				●	●	●	●	●	●	●
Analog I/O point features	Thermocouple linearization (32-bit floating point for linearized values)	n/a	n/a		●	●	●	●	●	●	●
	Minimum/maximum values				●	●	●	●	●	●	●
	Offset and gain				●	●	●	●	●	●	●
	Scaling				●	●	●	●	●	●	●
	TPO (Time-proportional output) ^s				●	●	●	●	●	●	●
	Output clamping				●	●	●	●	●	●	●
	Filter weight				●	●	●	●	●	●	●
	Watchdog timer				●	●	●	●	●	●	●
	Analog totalizing ^t				●	●	●	●	●	●	●
	Ramping ^t				●	●	●	●	●	●	●
PID logic (maximum 96 PID loops per controller or brain)				●	●	●	●	●	●	●	
Data logging				●	●	●	●	●	●	●	
Digital events, alarm events, serial events				●	●	●	●	●	● ^u	● ^u	
Event messaging				●	●	●	●	●			
UDP streaming of I/O data to host				●	●	●	●	●			
I/O point data mirroring and memory map copying				●	●	●	●	●			

a As provided by the Microsoft Windows computer the software runs on.
 b SoftPAC cannot communicate through serial ports on the PC.
 c Serial ports are software configurable for RS-232 or RS-485.
 d PAC firmware >=R9.4b, 8 max connections. Lower firmware, 2 max connections.
 f Available with OptoOPCServer and PAC Control, through a SNAP PAC controller.
 g SoftPAC includes Status Read, Status Write, and Scratch Pad memory map areas.
 h Models manufactured before August 2007 and S1s with serial numbers 625653 and lower have user-replaceable backup batteries. See original user's guide.
 i Flash memory function implemented via a file; size is limited only by disk space.
 k PAC firmware 9.4a and loader 6.1a or higher. S-series with microSD & manufacture date older than 06/14 supports max. 2 GB microSD.
 l Units with serial numbers lower than 500,000 have an 8–24 VDC input voltage rating. *Verify voltage on the unit's faceplate before applying power.*

n For compatibility with legacy Opto 22 hardware, see form #1693.
 o SNAP-PAC-R1s with serial numbers lower than 600,000, and all SNAP-PAC-R1-Bs: limited to eight 4-point digital modules per rack.
 p Not supported: serial, motion control, Profibus, & Wiegand modules.
 q Four-channel modules only; not high-density modules.
 r Requires a SNAP-IDC5Q quadrature input module.
 s Requires a SNAP analog TPO module (SNAP-AOD-29).
 t Requires a SNAP PAC controller and PAC Control commands.
 u Does not support serial events.

CHOOSING I/O

Up to this point, your choices have been easy: just two possible software suites, three basic types of controllers, and four I/O processors. Now the choices suddenly expand to include the full range of SNAP I/O: digital, analog, and serial input and output modules that directly connect to the devices, sensors, actuators, and machines you need to monitor and control.

One thing makes your choice easier: *all* SNAP I/O modules work with *all* R-series controllers. And all SNAP I/O modules except serial modules work with SB brains.

To choose I/O, take a look at the signals produced and received by everything you will monitor and control. Determine the combination of signals and the number of input and output points required at each physical location. Also look at the amount of wall or cabinet space available for the distributed I/O; if space is limited, you may want to use higher-density modules.

The next few sections include data to help you choose the I/O you need.

Module charts beginning on [page 27](#) show signal types and ranges, number of points, isolation, agency approvals, and more. Module specifications are in [Appendix A: I/O Specifications \(page 99\)](#).

Mounting rack information is on [page 33](#).

About Isolation

Opto 22 SNAP I/O modules provide various types of isolation to protect your system. Check the module charts and specifications to see which modules have which types. Here are the types of isolation and what they mean:

Optical isolation—Optical isolation on all solid-state modules provides 4,000 volts of transient (4000 V for 1 ms) protection for sensitive control electronics from industrial field signals. Optically isolated modules are isolated from all other modules on the same rack and from the I/O processor.

Channel-to-channel isolation—Channel-to-channel isolation (sometimes called “galvanic” isolation) provides isolation between points within the same module. On modules with this type of isolation, a measurement of the resistance between any terminal of one channel and any terminal of another channel will show infinite resistance. Modules that do not have channel-to-channel isolation have points that share a connection of the field signal (typically the common) inside the module.

Transformer isolation—Transformer isolation on analog modules helps prevent ground loop currents from flowing between field devices and causing noise that produces erroneous readings. Ground loop currents are caused when two grounded field devices share a connection, and the ground potential at each device is different. Analog modules provide 1500 volts of transformer isolation.

Digital Input Modules

The following table compares SNAP digital input modules. For use, see “SNAP Digital Q&A” on page 29.

Modules shaded dark gray are obsolete as of 2022. For detailed specifications, see the *Specs* column.

Input signal		Points	Isolation ¹		Part number	LEDs	Approvals						Warranty ²	Notes	Specs
Type	Range		Optical	Ch-ch			UL	CE	FM	CSA	ATEX	RoHS			
Voltage	-10 to -32 VDC	32	●	4	SNAP-IDC-32N ³	5	●					●	L	Positive common High density	105
	-2.5 to -12 VDC	32	●	4	SNAP-IDC-32DN ³	5	●					●	L	Positive common High density	105
	2.5 to 12 VDC	32	●	4	SNAP-IDC-32D ³	5	●					●	L	High density	105
	2.5–16 VDC	4	●	●	SNAP-IDC5-FAST	●	●	●	●	●	●	●	L	High speed	103
	2.5–28 VDC	4	●	●	SNAP-IDC5D	●	●	●	●	●	●	●	L		102
	10–32 VDC	32	●	4	SNAP-IDC-32 ³	5	●	●				●	L	High density	105
	10–32 VDC	32	●	4	SNAP-IDC-32-FM ³	5		●	●			●	L	High density	105
	10–32 VDC/VAC	16	●	●	SNAP-IDC-16 ³		●	●				●	L	High density	106
	10–32 VDC	4	●	●	SNAP-IDC5	●	●	●	●	●	●	●	L		102
	10–32 VDC	4	●	●	SNAP-IDC5FM	●		●	●			●	L		101
	10–32 VDC	4	●	●	SNAP-IDC5MA	●		●				●	30	Diagnostic switches	103
	15–28 VDC/VAC	16	●	●	SNAP-IDC-HT-16 ³			●				●	L	Leakage tolerant High density	106
	15–32 VDC	4	●	●	SNAP-IDC5-HT	●		●				●	L	Leakage tolerant	102
	18–32 VDC	4	●	●	SNAP-IDC5-FAST-A	●	●	●	●	●	●	●	L	High speed	103
	90–140 VAC/VDC	16	●	●	SNAP-IAC-16 ³		●	●				●	L	High density	106
	90–140 VAC/VDC	4	●	●	SNAP-IAC5	●	●	●	●	●	●	●	L		100
	90–140 VAC/VDC	4	●	●	SNAP-IAC5MA	●	●	●				●	30	Diagnostic switches	100
	180–280 VAC/VDC	4	●	●	SNAP-IAC5A	●	●	●	●	●	●	●	L		100
Dry Contact	Normally open	4	●		SNAP-IDC5-SW	●	●	●	●			●	L	Self wetting	104
	Normally closed	4	●		SNAP-IDC5-SW-NC	●	●	●				●	L	Self wetting	104
Quadrature	4–24 VDC	2	●	●	SNAP-IDC5Q	●	●	●	●	●	●	L	Quadrature input (two axes)	104	

1 For more information on isolation, see “About Isolation” on page 26.

2 Warranty period: L = Lifetime; 30 = 30 months from date of manufacture

3 For wiring options, see page 39.

4 Each group of 8 points is isolated from the other groups on the same module. Points within a group are not isolated from each other.

5 Status LEDs for individual points are available on a separate breakout board.

Digital Output Modules

The following table compares SNAP digital output modules. For usage information, see “SNAP Digital Q&A” on page 29. Detailed specifications are shown on the page in the *Specs* column.

Output signal		Points	Isolation ¹		Part number	LEDs	Approvals						Warranty ²	Notes	Specs
Type	Range		Optical	Ch-ch			UL	CE	FM	CSA	ATEX	RoHS			
Voltage (AC)	12–250 VAC	4	●		SNAP-OAC5	●	●	●	●	●	L		107		
	12–250 VAC	4	●	●	SNAP-OAC5-i	●	●	●		●	L		107		
	12–250 VAC	4	●	●	SNAP-OAC5MA	●	●	●		●	30	Diagnostic switches	107		
Voltage (DC)	5–60 VDC	32	●	³	SNAP-ODC-32-SNK ⁴	⁵	●	●		●	L	High density	113		
	5–60 VDC	32	●	³	SNAP-ODC-32-SRC ⁴	⁵	●	●		●	L	High density	113		
	5–60 VDC	4	●	●	SNAP-ODC5-i	●	●	●		●	L		113		
	5–60 VDC	4	●	●	SNAP-ODC5-iFM	●		●	●	●	L		112		
	5–60 VDC	4	●	●	SNAP-ODC5MA	●	●	●		●	30	Diagnostic switches	113		
	5–60 VDC	4	●		SNAP-ODC5SNK	●	●	●	●	●	L		108		
	5–60 VDC	4	●		SNAP-ODC5SNKFM	●		●	●	●	L		109		
	5–60 VDC	4	●		SNAP-ODC5SRC	●	●	●	●	●	L		108		
	5–60 VDC	4	●		SNAP-ODC5SRCFM	●		●	●	●	L		109		
	5–200 VDC	4	●	●	SNAP-ODC5A-i	●	●	●		●	L		113		
	5–200 VDC	4	●		SNAP-ODC5ASNK	●	●	●		●	L		113		
Mechanical Relay	6 A @ 250 VAC or 30 VDC	4		●	SNAP-OMR6T-C	●	●	●		●	30	SPDT (Form C)	115		
		4		●	SNAP-OMR6-C	●	●	●		●	30	SPST (Form C)	115		
Dry Contact	Normally open	4		●	SNAP-ODC5R	●		●	●	●	30	Reed relay, ≤10 VA	110		
	Normally open	4		●	SNAP-ODC5RFM	●		●	●	●	30	Reed relay, ≤10 VA	109		
	Normally closed	4		●	SNAP-ODC5R5	●		●		●	30	Reed relay, ≤10 VA	110		

1 For more information on isolation, see [“About Isolation” on page 26](#).

2 Warranty period: L = Lifetime; 30 = 30 months from date of manufacture

3 Each group of eight points is isolated from the other groups. Points within a group are not isolated from each other.

4 For wiring options, see [page 39](#).

5 Status LEDs for individual points are available on a separate breakout board.

SNAP Digital Q&A

Q: What is the difference between the SRC and SNK digital DC output modules?

A: SRC and SNK stand for SouRCing and SiNKing, respectively. Because one fuse is used for all output channels on the module, Opto 22 designed two different varieties. The selection of the module type depends on which side of the load the module is placed on. Typically, a SRC module is used between the + terminal and the load, while a SNK module would be used between the load and the –, ground, or common terminal. Please note that if the wrong module is used in the wrong place, all channels will effectively become common and all loads will be activated if any one channel is turned on.

Q: Why is there only one digital AC output module when there are two DC modules?

A: Only one AC module design is required, because unlike the transistors used in the DC modules, the switching devices used in the AC module are non-polar. So as long as all channels on the module are wired in the same way, the AC module can be used for sourcing or sinking.

Q: Is there any way to get more than 0.75 A current capacity out of each channel on the 4-channel digital output module?

A: Yes. SNAP 4-channel digital output modules are not rated on a channel-to-channel basis; instead, the entire module is rated for a maximum of 3 A. Any one channel on the module can carry up to 3 A, as long as the total current being carried by the module is 3 A or less. Thus, two of four channels can be used to carry 1.5 A each, with two channels unused.

Q: Can I wire the channels on a SNAP digital output module in parallel to obtain a higher current rating?

A: This question is related to the question above. There really isn't a need to wire channels in parallel, because each channel can carry up to 3 A; just be certain that the total current passing through the module is 3 A or less. Wiring the channels in parallel will not make any difference as far as performance goes; one channel will likely activate before the others and thus take up the entire load itself anyway. Parallel wiring does allow for some automatic fallback redundancy in case one channel fails open, however.

Q: Is there a SNAP digital input module for DC voltages over 32 V?

A: Yes. SNAP AC input modules may be used for DC input up to their voltage rating. For example, a SNAP-IAC5 can be used to read 125 VDC input signals. Most SNAP input modules use a full-wave rectifier on the input, allowing the module to be used as an AC or DC input and making it resistant to reversed-polarity installations.

Q: Is there a way to read low-voltage AC signals with a SNAP input module?

A: Yes. In the same way that SNAP AC modules can be used for DC, some SNAP DC modules can be used to take low-voltage AC signals, such as the 24 VAC commonly used in HVAC systems. This is allowable with all SNAP DC modules containing a full-wave rectifier.

Analog Input Modules

The following table compares SNAP analog input modules. For resolution information, see “SNAP Analog Q&A” on page 32. Detailed specifications are shown on the page in the *Specs* column.

Input signal		Points	Isolation ¹			Part number	Approvals						Warranty ²	Notes	Specs
Type	Range		Optical	Ch-ch	Transformer		UL	CE	FM	CSA	ATEX	RoHS			
Current	-20 to +20 mA	32	●	●	●	SNAP-AIMA-32 ³	●	●			●	L		120	
	-20 to +20 mA	8	●	●	●	SNAP-AIMA-8		●			●	L		119	
	-20 to +20 mA	4	●	●	●	SNAP-AIMA-4	●	●	●	●	●	L		119	
	-20 to +20 mA	2	●	●	●	SNAP-AIMA	●	●	●		●	L		119	
	-20 to +20 mA	2	●	●	●	SNAP-AIMA-i	●	●	●		●	L		121	
	-20 to +20 mA	2	●	●	●	SNAP-AIMA-ISRC		●			●	L	Isolated loop excitation	122	
	-20 to +20 mA	2	●	●	●	SNAP-AIMA-ISRC-FM		●	●		●	L	Isolated loop excitation	122	
	-1 to +1 mA	2	●	●	●	SNAP-AIMA2-i		●			●	L		120	
Voltage (mV)	2 or 3 mV/V	2	●	●	●	SNAP-AILC		●			●	L	Load cell devices	117	
	3 or 4 mV/V	2	●	●	●	SNAP-AILC-2		●			●	L	Load cell devices	117	
	-50 to +50 mV or -25 to +25 mV (or thermocouple)	2	●	●	●	SNAP-AITM-2		●	●		●	L		129	
		2	●	●	●	SNAP-AITM2-i	●	●	●		●	L		129	
	+/-75, +/-50, or +/-25 mV (or thermocouple)	8	●	●	●	SNAP-AITM-8	●	●			●	L		132	
	-150 to +150 mV or -75 to +75 mV	4	●	●	●	SNAP-AIMV-4	●	●	●		●	L		124	
	-150 to +150 mV or -75 to +75 mV (or thermocouple)	2	●	●	●	SNAP-AITM		●	●		●	L		128	
		2	●	●	●	SNAP-AITM-i	●	●	●		●	L		131	
Voltage (V)	-10 to +10 VDC or -5 to +5 VDC	32	●	●	●	SNAP-AIV-32 ³	●	●			●	L		134	
	-10 to +10 VDC or -5 to +5 VDC	8	●	●	●	SNAP-AIV-8		●			●	L		134	
	-10 to +10 VDC or -5 to +5 VDC	4	●	●	●	SNAP-AIV-4	●	●	●	●	●	L		133	
	-10 to +10 VDC or -5 to +5 VDC	2	●	●	●	SNAP-AIV	●	●	●		●	L		133	
	-10 to +10 VDC or -5 to +5 VDC	2	●	●	●	SNAP-AIV-i	●	●	●		●	L		130	
	-100 to +100 VDC	2	●	●	●	SNAP-AIV2-i		●			●	L		133	
RMS	0–10 A RMS	2	●	●	●	SNAP-AIARMS	●	●	●		●	L		116	
	0–10 A RMS	2	●	●	●	SNAP-AIARMS-i		●			●	L		117	
	0–250 V RMS	2	●	●	●	SNAP-AIVRMS	●	●	●		●	L		135	
	0–250 V RMS	2	●	●	●	SNAP-AIVRMS-i		●			●	L		135	
Rate	0–25,000 Hz	2	●	●	●	SNAP-AIRATE	●	●	●		●	L		123	
	2 Hz to 500 kHz	2	●	●	●	SNAP-AIRATE-HFi		●			●	L		123	

Input signal		Points	Isolation ¹			Part number	Approvals						Warranty ²	Notes	Specs
Type	Range		Optical	Ch-ch	Transformer		UL	CE	FM	CSA	ATEX	RoHS			
Resistance	40, 20, 10, or 5 K ohms	4	●		●	SNAP-AIR40K-4	●	●	●		●	L	Thermistor input	128	
	400, 200, 100, 50, 40, 20, 10, 5, 4, 2, or 1 K Ohm; or 500 Ohm	8	●		●	SNAP-AIR400K-8	●	●			●	L	Thermistor input	127	
	Multiple ranges from 0–8000 Ohm	8	●		●	SNAP-AIRTD-8U	●	●			●	L	Also temperature	126	
Voltage	Dual-range voltage	1	●		●	SNAP-AIV-72		●			●	L	Aluminum industry		
Temperature	ICTD	8	●		●	SNAP-AICTD-8		●			●	L		118	
	ICTD	4	●		●	SNAP-AICTD-4	●	●	●		●	L		118	
	ICTD	2	●		●	SNAP-AICTD	●	●	●		●	L		118	
	100 Ohm Platinum RTD	2	●		●	SNAP-AIRTD	●	●	●		●	L		125	
	10 Ohm Copper RTD	2	●		●	SNAP-AIRTD-10		●			●	L		125	
	1000 Ohm Platinum RTD	2	●		●	SNAP-AIRTD-1K		●			●	L		125	
	1K Ohm Pt/Ni RTD, 100 Ohm Pt/Ni RTD, 120 Ohm Ni RTD, 10 Ohm Cu RTD	8	●		●	SNAP-AIRTD-8U	●	●			●	L	Also resistance	126	
	Thermocouple type B,C,D, G,N,T,R,S (or -50 to +50 mV or -25 to +25 mV)	2	●		●	SNAP-AITM-2		●	●		●	L		129	
		2	●	●	●	SNAP-AITM2-i	●	●	●		●	L		129	
	Thermocouple type B,C,D,E,G,J,K,N,R,S, T (or +/-75, +/-50, or +/-25 mV)	8	●		●	SNAP-AITM-8		●			●	L		132	
Thermocouple type E,J,K (or -150 to +150 mV or -75 to +75 mV)	2	●		●	SNAP-AITM		●	●		●	L		128		
	2	●	●	●	SNAP-AITM-i	●	●	●		●	L		131		
Thermocouple type B,C,D,E,G,J,K,N,R,S, T (or +/-150, +/-75, +/-50, or +/-25 mV)	4	●	●	●	SNAP-AITM-4i		●			●	L		129		

1 For more information on isolation, see [“About Isolation” on page 26](#).

2 Warranty period: L = Lifetime; 30 = 30 months from date of manufacture

3 For wiring options, see [page 39](#).

4 Two points of physical input (current and voltage) per phase, plus calculated data points (true power, volt-amps)

Analog Output Modules

The following table compares SNAP analog output modules. For resolution information, see “SNAP Analog Q&A,” below. Detailed specifications are shown on the page in the *Specs* column.

Output signal		Points	Isolation ¹			Part number	Approvals						Warranty ²	Notes	Specs
Type	Range		Optical	Ch-ch	Transformer		UL	CE	FM	CSA	ATEX	RoHS			
Current	0–20 mA	2	●		●	SNAP-AOA-28	●	●	●		●	●	L		138
	4–20 mA	2	●		●	SNAP-AOA-23	●	●	●			●	L		136
	4–20 mA	2	●	●	●	SNAP-AOA-23-iSRC		●				●	L	Isolated loop sourcing	137
	4–20 mA	2	●	●	●	SNAP-AOA-23-iSRC-FM		●	●		●	●	L	Isolated loop sourcing	137
	4–20 mA	1	●		●	SNAP-AOA-3	●	●				●	L		136
Current/ Voltage	4 to 20 mA 0 to 20 mA 0 to 5 VDC 0 to 10 VDC -5 to +5 VDC -10 to +10 VDC	8	●		●	SNAP-AOVA-8		●				●	L	Multifunction	136
Voltage	-10 to +10 VDC	2	●		●	SNAP-AOV-27	●	●	●			●	L		141
	0–10 VDC	2	●		●	SNAP-AOV-25	●	●	●			●	L		140
	0–10 VDC	1	●		●	SNAP-AOV-5	●	●				●	L		140
	5–60 VDC	2	●	●	●	SNAP-AOD-29	●	●	●			●	L	Time-proportional out-put ³	139
	2.5–24 VDC	2	●	●	●	SNAP-AOD-29-HFi		●				●	L	Time-proportional out-put ³	139

1 For more information on isolation, see “About Isolation” on page 26.

2 Warranty period: L = Lifetime; 30 = 30 months from date of manufacture

3 SNAP-PAC brains and rack-mounted controllers with high-speed digital functions also provide TPO on digital output modules.

SNAP Analog Q&A

Q: What type of resolution do SNAP analog inputs provide?

A: SNAP analog input modules have a typical resolution of ±25,000 counts. This equates to roughly 14.5-bit resolution plus sign, or 15.5-bit full-scale resolution. These odd resolutions are a result of the inherent accuracy of the input amplifiers used to buffer the analog-to-digital converter from the signal source. While the analog-to-digital converter may be capable of providing higher resolution numbers, these numbers are not useful because of the low precision level of the signal conditioning circuitry and the amount of noise inherent in any electrical signal.

Q: What type of resolution do SNAP analog output modules achieve?

A: SNAP analog outputs are 12-bit resolution, yielding 4,095 counts from zero to full-scale.

Serial Communication Modules

Serial communication modules can be used with all EB brains and R-series controllers. They cannot be used with SB serial brains. The following table compares SNAP serial communication modules. Detailed specifications are shown on the page in the *Specs* column.

Input/output	Ports	Isolation ¹		Part number	LEDs	Approvals					Warranty ²	Notes	Specs
		Optical	Ch-ch			UL	CE	FM	CSA	RoHS			
RS-232	2	●	●	SNAP-SCM-232	●	●	●	●	●	30	Optional RTS/CTS flow control	143	
RS-485/422	2 ³	●	●	SNAP-SCM-485-422	●	●	●	●	●	30	2-wire or 4-wire	143	
Pulse & direction	2	●		SNAP-SCM-ST2	●	●			●	30	For stepper motors	143	
Controller Area Network (CAN)	1	●		SNAP-SCM-CAN2B		●	●		●	30	Transmit and receive	144	

¹ For more information on isolation, see [“About Isolation” on page 26](#).

² Warranty period: L = Lifetime; 30 = 30 months from date of manufacture

³ Two ports if module is in 2-wire mode; one port if in 4-wire mode

I/O Mounting Racks

SNAP PAC mounting racks hold one processor (brain or R-series controller) and up to 4, 8, 12, or 16 modules. Use two 4-40 by ½-inch standard machine screws to hold each module securely in position on the SNAP rack. All kinds of SNAP I/O modules—analogue, 4-channel and high-density digital, and serial—can be mixed together on any rack with any processor. (*Exception:* a SNAP-PAC-R1-B controller mounts on legacy SNAP B-series racks. This controller is used to update older I/O racks to the SNAP PAC System.)

Mounting rack part numbers are:

- **SNAP-PAC-RCK4** (up to 4 modules)
- **SNAP-PAC-RCK8** (up to 8 modules)
- **SNAP-PAC-RCK12** (up to 12 modules)
SNAP-PAC-RCK12-FM (Factory Mutual approved)
- **SNAP-PAC-RCK16** (up to 16 modules)
SNAP-PAC-RCK16-FM (Factory Mutual approved)

If cabinet space for distributed I/O is limited and the capabilities fit your needs, choose higher density modules.

CHOOSING POWER SUPPLIES

Primary Power Supply

NOTE: For a more general discussion of using power supplies with Opto 22 systems, see Opto 22 form #1271, a technical note available on our website at www.opto22.com.

SNAP racks use a 5 VDC power source (5 VDC [-0.0, +0.1] at minimum 4.0 amps recommended). For systems using AC source voltage, the SNAP-PS5 or SNAP-PS5U power supply is recommended. For DC systems, such as those using DC backup power, the SNAP-PS5-24DC offers DC-to-DC power.

In general, we recommend you **use an independent, isolated, regulated power supply locally with each rack**. Local isolated supplies offer these advantages:

- Short supply conductors, which minimize losses

CHOOSING POWER SUPPLIES

- Power redundancy, so the failure of a single supply causes only a single rack failure, not a total system failure
- Fewer voltage drops and ground loops. (Voltage drops and subsequent ground loops may occur when power is distributed over a large system.)

Always **use a separate power supply for the field side of the I/O**. Using the rack supply for field actuation and monitoring defeats the isolation the I/O module offers and therefore increases the chance of a ground loop within the control system. Additionally, a sudden change of current on the field side can cause undesirable voltage fluctuations that may interfere with the computer's operation.

Determining Power Requirements

Both the SNAP-PS5 and the SNAP-PS5-24DC power supplies provide 5 VDC power for loads up to 4 amps. The SNAP-PS5U provides 5 VDC for loads up to 5 amps. In most cases this power is sufficient for a SNAP processor, a rack, and the associated I/O modules. However, some combinations of modules, especially serial modules, may require additional power. You can use the following tables to help determine power needs for your I/O units.

Processor Power Requirements

	Processor (Brain or Rack-mounted Controller)	Power Req. (Amps)*
	SNAP PAC R-series controllers (all wired models)	1.200
	SNAP PAC SB brains	0.750
Obsolete	SNAP PAC EB brains (all wired models)	0.750
	SNAP PAC R-series controllers (Wired+Wireless)	1.500
	SNAP PAC EB brains (Wired+Wireless)	1.000
*Current from 5-volt supply		

I/O Unit (Processor, Rack, and I/O Modules) Power Requirements Worksheet

Item	Quantity	X Power Req. (Amps)	Total Power Required (Amps) ¹
SNAP processor (Enter Amps from Processor Power Requirements table)	1		
SNAP-IDC5-SW digital input module			
SNAP-IDC5-SW-NC digital input module			
SNAP-AITM-8 analog input module		0.200	
Isolated analog input and output modules (part numbers ending in -i or iSRC) except SNAP-AITM-4i			
All other 4-channel digital input and output modules except mechanical relay outputs (<i>not</i> high-density digital modules)		0.050	
SNAP mechanical power relay output modules		0.160	
SNAP-AICTD, AICTD-4 analog input modules			
High-density digital input and output modules			
SNAP-AIMA-32, SNAP-AIMA-iH, SNAP-AIV-32, and SNAP-AITM-4i analog input modules		0.150	
All analog output modules except SNAP-AOA-iSRC and SNAP-AOD-29-HFi			
SNAP-AOD-29-HFi		0.300	
SNAP-AIPM power monitoring module		0.100	
SNAP-AIPM-3, SNAP-AIPM-3V power monitoring modules			
SNAP-AILC and AILC-2 load cell modules		0.120	
SNAP-AIRTD-8U analog input module		0.135	
SNAP-AIARMS analog input module			
SNAP-AIVRMS analog input module			
SNAP-AICTD-8 analog input module			
SNAP-AIMA, AIMA-4, and AIMA-8 analog input modules		0.170	
SNAP-AITM and AITM-2 analog input modules			
SNAP-AIMV-4 and AIMV2-4 analog input modules			
SNAP-AIV, AIV-4, and AIV-8 analog input modules			
SNAP-AIRTD analog input module			
SNAP-AIR40K-4 analog input module		0.190	
SNAP-AIR400K-8 analog input module			
SNAP-AIRATE analog input module			
SNAP-AIRATE-HFi analog input module		0.210	
SNAP-SCM-ST2 and SNAP-SCM-SSI serial modules		0.200	
SNAP-SCM-232, SNAP-SCM-485-422, SNAP-SCM-PROFI			
SNAP-SCM-MCH16 <i>not</i> powering a breakout board		0.250	
SNAP-SCM-MCH16 powering a breakout board		0.700	
Total			

¹ Current from 5-volt supply

IMPORTANT: For a SNAP-PS5 or a SNAP-PS5-24DC power supply, the total power required must not exceed 4 Amps. For a SNAP-PS5U, the total power required must not exceed 5 Amps.

Loop Power Supply

Some analog modules (for example, some SNAP-AIMA modules) also require a current loop supply, which can be provided by the SNAP-PS24 or the SNAP-PS24U. Both offer 24 volts of DC power, the SNAP-PS24 at 0.75 A and the SNAP-PS24U at 1.25 A.

Warranty Information and FM Approval

The Opto 22 warranty on all SNAP power supplies is 30 months.

The SNAP-PS5, SNAP-PS24, and SNAP-PS5-24DC power supplies are Factory Mutual approved.

SIMPLIFYING INSTALLATION WITH SNAP TEX ACCESSORIES

Wiring field devices to I/O can be a time-consuming and expensive process. SNAP TEX wiring and mounting accessories make it easier to install and wire your SNAP PAC System.

SNAP TEX cables are pre-made cables that snap into I/O modules and provide flying leads or a connector for field wiring. You can use these cables with SNAP TEX breakout boards or your own boards, or wire directly to field devices. To choose cables for your SNAP I/O modules, see the tables beginning on [page 37](#).

SNAP TEX breakout boards move terminals away from the crowded rack area for easier installation and maintenance. Some offer additional features such as built-in fusing, bussed power to loads, and G4 modules or mechanical relays for higher current switching. To choose the breakout boards to use with your I/O modules and cables, see the tables beginning on [page 37](#).

For more information on SNAP TEX cables and breakout boards, see form #1756, the *SNAP TEX Cables and Breakout Boards Data Sheet*.

DIN-rail clips and kits mount power supplies, controllers, and I/O mounting racks to DIN rails. To find out which DIN-rail clips to use (and how many), see the table on [page 40](#).

Mounting and wiring **tools, spare parts, jumper straps**, and **rack adapters** for use with legacy brains are also available. See form #1772, the *SNAP TEX Mounting & Wiring Tools and Spare Parts Data Sheet* for more information.

Module, Breakout Board, and Cable Compatibility Charts

In the charts starting on the following page, look in the left column for the module you have. Choose the breakout board in the right columns. Compatible cables are shown in the table cells in the center.

4-Channel Digital Modules

Module	Breakout Board	Obsolete Breakout Boards	
	SNAP-TEX-32 **	SNAP-TEX-FB16-H SNAP-TEX-FB16-L	SNAP-TEX-MR10-4 SNAP-TEX-MR10-16 SNAP-TEX-MR10-16C
Digital input modules—4-point			
SNAP-IAC5 SNAP-IAC5A SNAP-IAC5AFM SNAP-IAC5FM SNAP-IAC5MA SNAP-IDC5MA	SNAP-TEX-CBS6 *	SNAP-TEX-CBS6 *	Not used for inputs
SNAP-IDC5 SNAP-IDC5-FAST-A SNAP-IDC5-HT SNAP-IDC5D SNAP-IDC5DFM SNAP-IDC5FAST SNAP-IDC5FM SNAP-IDC5G	SNAP-TEX-CBE6 SNAP-TEX-CBO6 SNAP-TEX-CBS6	SNAP-TEX-CBO6 SNAP-TEX-CBS6	Not used for inputs
SNAP-IDC5Q	SNAP-TEX-CBS6	Not used	Not used for inputs
SNAP-IDC5-SW SNAP-IDC5-SW-NC	SNAP-TEX-CBS6	Not used	Not used for inputs
Digital output modules—4-point			
SNAP-ODC5-I SNAP-ODC5-IFM SNAP-ODC5A-I SNAP-ODC5A-IFM SNAP-ODC5MA	SNAP-TEX-CBS6 *	SNAP-TEX-CBS6 *	SNAP-TEX-CBO6 SNAP-TEX-CBS6
SNAP-OAC5-I SNAP-OAC5-IFM SNAP-OAC5MA	SNAP-TEX-CBS6 *	SNAP-TEX-CBS6 *	Not used
SNAP-ODC5SRC SNAP-ODC5SRCFM	SNAP-TEX-CBO6 SNAP-TEX-CBS6	SNAP-TEX-CBO6 SNAP-TEX-CBS6	SNAP-TEX-CBO6 SNAP-TEX-CBS6
SNAP-OAC5 SNAP-OAC5FM SNAP-ODC5ASNK SNAP-ODC5R SNAP-ODC5R5 SNAP-ODC5R5FM SNAP-ODC5RFM SNAP-ODC5SNK SNAP-ODC5SNKFM	SNAP-TEX-CBE6 SNAP-TEX-CBO6 SNAP-TEX-CBS6	SNAP-TEX-CBO6 SNAP-TEX-CBS6	Not used
SNAP-OMR6T-C SNAP-OMR6-C	Not used	Not used	Not used

* This cable maintains channel-to-channel isolation on these modules. If channel-to-channel isolation is not important, you can also use the SNAP-TEX-CBO6 cable.

** The SNAP-TEX-32 can be used with digital outputs but has no fuses. SNAP-TEX-FB16 boards (obsolete) are preferable for digital outputs because they include fuses.

1-, 2-, and 4-Channel Analog Modules

Module		Breakout Board	Obsolete Breakout Boards	
		SNAP-TEX-32	SNAP-TEX-FB16-H SNAP-TEX-FB16-L	SNAP-TEX-MR10-4 SNAP-TEX-MR10-16 SNAP-TEX-MR10-16C
Analog input modules (not thermocouples)				
SNAP-AIARMS	SNAP-AIRATE	SNAP-TEX-CBS6	Not used for analog modules	
SNAP-AIARMS-i	SNAP-AIRATE-HFi			
SNAP-AIARMS-i-FM	SNAP-AIRTD			
SNAP-AICTD	SNAP-AIRTD-10			
SNAP-AICTD-4	SNAP-AIRTD-1K			
SNAP-AILC ^a	SNAP-AIV-72			
SNAP-AILC-2 ^a	SNAP-AIV-i			
SNAP-AIMA-i	SNAP-AIV2-i			
SNAP-AIMA-iSRC ^a	SNAP-AIVRMS			
SNAP-AIMA-iSRC-FM ^a	SNAP-AIVRMS-i			
SNAP-AIMA-iH	SNAP-AIVRMS-i-FM			
SNAP-AIMA2-i				
SNAP-AIMA	SNAP-AIR40K-4			
SNAP-AIMA-4	SNAP-AIV			
SNAP-AIMV2-4	SNAP-AIV-4			
SNAP-AIMV-4				
SNAP-AIPM	SNAP-AITM-2 ^c	No cable available	Not used for analog modules	
SNAP-AIPM-3 ^b	SNAP-AITM-4i ^c			
SNAP-AIPM-3V	SNAP-AITM2-i ^c			
SNAP-AITM ^c	SNAP-pH/ORP			
SNAP-AITM-i ^c				
Analog output modules				
SNAP-AOA-23	SNAP-AOA-28	SNAP-TEX-CBE6 SNAP-TEX-CBS6	Not used for analog modules	
SNAP-AOA-3	SNAP-AOV-5	SNAP-TEX-CBE6 SNAP-TEX-CBO6 SNAP-TEX-CBS6	Not used for analog modules	
SNAP-AOV-25	SNAP-AOV-27	SNAP-TEX-CBO6	Not used for analog modules	
SNAP-AOA-23-iH	SNAP-AOD-29	SNAP-TEX-CBS6	Not used for analog modules	
SNAP-AOA-23-iSRC ^a	SNAP-AOD-29-HFi			
SNAP-AOA-23-iSRC-FM ^a				

^a Note that the SNAP-TEX-SBS6 cable does not include a connector for the 2-pin terminal on top of these modules, required for excitation voltage.

^b Not recommended for use with breakout boards due to CT safety concerns.

^c Do not use breakout boards with thermocouples.

High-Density Digital Modules

Module	Breakout Board							Without a breakout board
	SNAP-TEX-32	(Both obsolete) SNAP-TEX-FB16-H SNAP-TEX-FB16-L	(All obsolete) SNAP-TEX-MR10-4 SNAP-TEX-MR10-16 SNAP-TEX-MR10-16C	SNAP-IDC-HDB SNAP-IDC-HDB-FM (-FM model obsolete)	SNAP-ODC-HDB SNAP-ODC-HDB-FM (-FM model obsolete)	SNAP-JDC-HDB	SNAP-JDC-HDB-G4	
SNAP-IAC-16 SNAP-IAC-A-16 SNAP-IAC-K-16 SNAP-IDC-16 SNAP-IDC-HT-16	SNAP-HD-ACF6 (2 modules/ board)	SNAP-HD-ACF6	Not used with inputs	Not used	Not used	Not used	Not used	SNAP-HD-ACF6
SNAP-IDC-32 SNAP-IDC-32-FM SNAP-IDC-32D SNAP-IDC-32N SNAP-IDC-32DN	SNAP-HD-CBF6	SNAP-HD-CBF6 (2 boards/ module)	Not used with inputs	SNAP-HD-BF6	Not used	SNAP-HD-BF6	Not used SNAP-HD-BF6	SNAP-HD-CBF6
SNAP-ODC-32-SNK SNAP-ODC-32-SNK-FM	SNAP-HD-CBF6	SNAP-HD-CBF6 (2 boards/ module)	Do not use	Not used			SNAP-HD-BF6	
SNAP-ODC-32-SRC SNAP-ODC-32-SRC-FM	SNAP-HD-CBF6	SNAP-HD-CBF6 (2 boards/ module)	SNAP-HD-CBF6 SNAP-HD-G4F6 (MR10-16C only)	Not used	SNAP-HD-BF6	SNAP-HD-BF6	Not used	SNAP-HD-CBF6

Analog Modules with More Than 4 Points

Module	Breakout Board			Without a breakout board		
	SNAP-TEX-32	SNAP-TEX-FB16-H* SNAP-TEX-FB16-L* SNAP-TEX-MR10-4* SNAP-TEX-MR10-16* SNAP-TEX-MR10-16C* SNAP-IDC-HDB SNAP-IDC-HDB-FM* SNAP-ODC-HDB SNAP-ODC-HDB-FM*	SNAP-AIMA-HDB SNAP-AIMA-HDB-FM*		SNAP-AIV-HDB SNAP-AIV-HDB-FM*	
SNAP-AICTD-8 SNAP-AIMA-8 SNAP-AIR400K-8 SNAP-AIRTD-8U SNAP-AITM-8 ** SNAP-AITM-8-FM ** SNAP-AIV-8	Can be used; no cable currently available			Not used	No cable available	
SNAP-AIMA-32 SNAP-AIMA-32-FM	Not recommended			SNAP-HD-BF6	SNAP-HD-BF6***	Not recommended
SNAP-AIV-32 SNAP-AIV-32-FM	SNAP-HD-CBF6			Not used	SNAP-HD-BF6	SNAP-HD-CBF6
SNAP-AOVA-8	SNAP-HD-20F6				Not used	SNAP-HD-20F6

* Obsolete part

** Do not use breakout boards with thermocouples.

*** For specific applications. See details in wiring diagrams.

DIN-Rail Clips and Kits

For these SNAP products		Clips needed	Use this adapter clip	Use this end cap
Power Supplies				
SNAP-PS5 SNAP-PS24	SNAP-PS5-24DC	1 kit	SNAP-PSDIN	N/A
SNAP-PS5U	SNAP-PS24U	1 kit	SNAP-PSUDIN	N/A
Controllers				
SNAP-PAC-S1 SNAP-PAC-S1-W*	SNAP-PAC-S1-FM	1 kit	SNAP-PSDIN	N/A
SNAP-PAC-S2	SNAP-PAC-S2-W*	1 kit	SNAP-S2DIN	N/A
Mounting Racks				
SNAP-PAC-RCK4	SNAP-PAC-RCK4-FM*	2 clips		
SNAP-PAC-RCK8 SNAP-PAC-RCK8-FM*	SNAP-PAC-RCK12 SNAP-PAC-RCK12-FM	3 clips	SNAP-TEX-DRC10** (10 clips in package)	SNAP-TEX-REC10W** (10 in package; use 2 per rack)
SNAP-PAC-RCK16	SNAP-PAC-RCK16-FM	4 clips		
Breakout Boards				
SNAP-TEX-MR10-4*		2 clips	SNAP-TEX-DRC10** (10 clips in package)	SNAP-TEX-REC10W** (10 in package; use 2 per rack)
SNAP-TEX-MR10-16*	SNAP-TEX-MR10-16C*	3 clips		
SNAP-AIMA-HDB SNAP-AIMA-HDB-FM* SNAP-AIV-HDB SNAP-AIV-HDB-FM* SNAP-UDC-HDB	SNAP-IDC-HDB SNAP-IDC-HDB-FM* SNAP-TEX-32 SNAP-TEX-FB16-H* SNAP-TEX-FB16-L*	2 clips	SNAP-TEX-DRC10** (10 clips in package)	SNAP-TEX-REC10N** (10 in package; use 2 per board)
SNAP-ODC-HDB SNAP-ODC-HDB-FM*	SNAP-SCM-BB4*	3 clips		
Other SNAP Devices				
SNAP-PAC-SRA	SNAP-RPSW	1 kit	SNAP-ROKDIN*	N/A

* Obsolete part

** Requires the black plastic extrusion that comes with new racks and boards. Older racks and boards have a light-colored plastic extrusion. The black plastic extrusion is not sold separately. It is included with a new board or rack.

3: Networking Options

INTRODUCTION

You should already be familiar with TCP/IP and Ethernet networking before you set up your SNAP PAC System. If you're using serial I/O, you should know about serial networking. If you are not familiar with these subjects, we strongly suggest you consult some of the many commercially available resources to learn about them.

If your SNAP PAC System will be part of an existing Ethernet network or will communicate with an existing network, be sure to work closely with your system administrator before setting up the network or assigning IP addresses. For more about networking, see form 1796, [Guide to Networking SNAP PAC Products](#).

This chapter discusses some optional Ethernet and serial networking arrangements for the SNAP PAC System, including the following:

Network interfaces on SNAP PAC controllers and brains	See below
Using redundant Ethernet network links	See page 46
Isolating Ethernet networks into zones	See page 48
Communicating with Modbus/TCP [®] systems	See page 48
Communicating with Allen-Bradley [®] PLC systems	See page 49
Using distributed serial I/O	See page 50
Connecting directly to serial devices	See page 50
Communicating with a remote host using a modem	See page 50
Communicating with legacy serial <i>mistic</i> I/O	See page 51

NETWORK INTERFACES ON SNAP PAC CONTROLLERS AND BRAINS

SNAP-PAC-S1 Controller—Network Interfaces and Ports

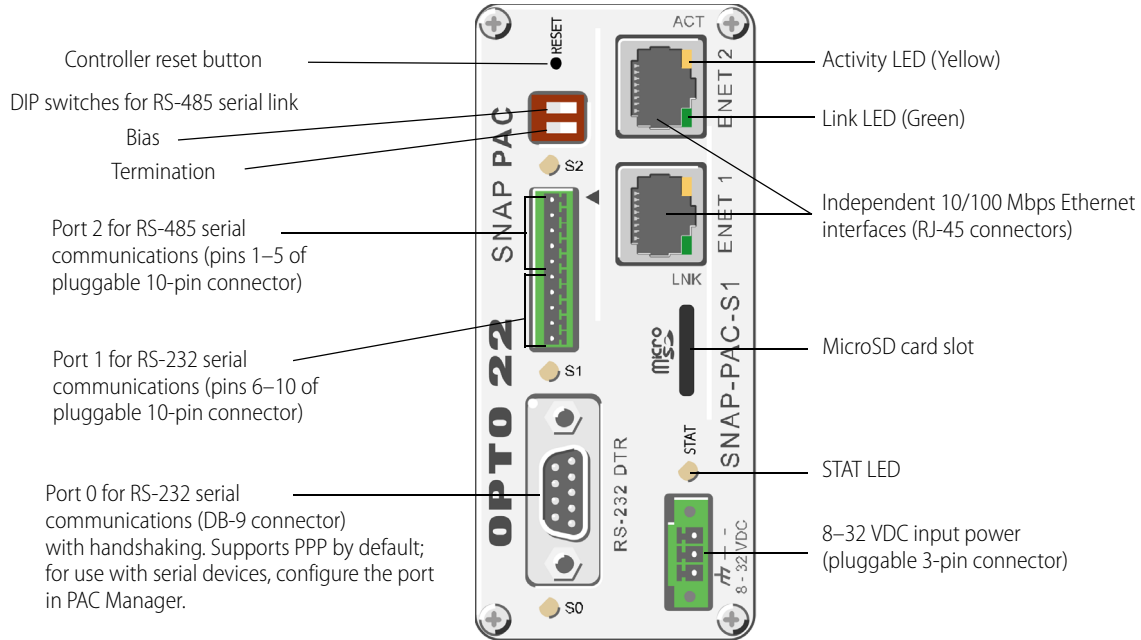

Status and Activity LEDs

Indicator	Description
S0	RS-232 serial activity on port 0
S1	RS-232 serial activity on port 1
S2	RS-485 serial activity
STAT	Startup status and control program operational status
ACT	Ethernet network activity
LINK	Link established with Ethernet network

Port 0 for RS-232 serial (DB-9 connector)

Pin	Description	Signal Direction
1	DCD	In
2	RX	In
3	TX	Out
4	DTR	Out
5	COM	
6	DSR	In
7	RTS	Out
8	CTS	In
9	RI*	In

* RI signal does not occur on PACs with a microSD card slot

Ports 1 and 2 for RS-485 and RS-232 serial

	Pin	Description	Signal Direction
Port 2 for RS-485 serial (2-Wire)	1	TX/RX+	In/Out
	2	TX/RX-	In/Out
	3	SIG COM*	
	4	IRQ+	In
	5	IRQ-	In
Port 1 for RS-232 serial	6	TX	Out
	7	RX	In
	8	GND	
	9	RTS	Out
	10	CTS	In

* Isolated ground

SNAP-PAC-S2 Controller—Network Interfaces and Ports

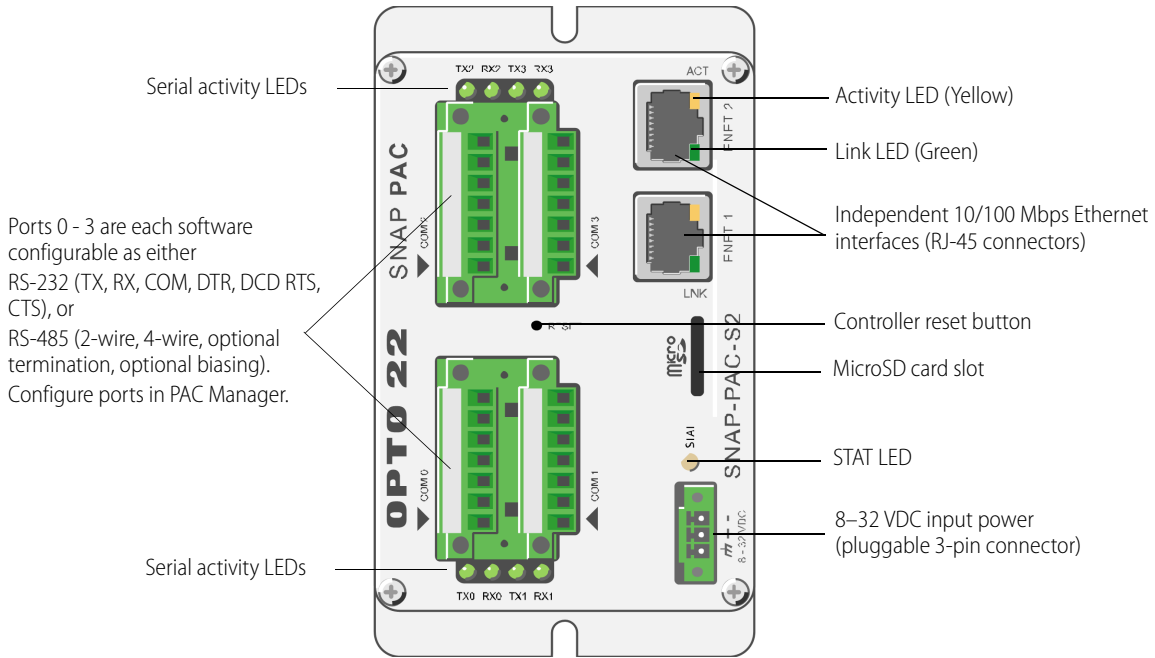

RS-485 and RS-232 Ports¹

Pin	RS-232	Signal Direction	RS-485	Signal Direction
1	TX	Out	TX/RX+	In/Out
2	RX	In	TX/RX-	In/Out
3	COM ²		COM ²	
4	RTS	Out	RX+ (4 wire)	In
5	CTS	In	RX- (4 wire)	In
6	DTR	Out	IRQ+	In
7	DCD	In	IRQ-	In

¹ **CAUTION: Do not use communication port connectors from a legacy OptoControl controller*.** Legacy connectors will fit in a SNAP-PAC-S2, but the pin orientation is different. Instead, use the connectors supplied with the SNAP-PAC-S2 controller.

² Isolated ground. (Each channel is isolated from the others.)

*Legacy OptoControl Controllers:

G4LC32	G4LC32ISA-LT	M4RTU
G4LC32SX	M4	SNAP-LCM4
G4LC32ISA	M4IO	SNAP-LCSX/PLUS

Status and Activity LEDs

Indicator	Description
TX0/RX0	Serial activity on port 0
TX1/RX1	Serial activity on port 1
TX2/RX2	Serial activity on port 2
TX3/RX3	Serial activity on port 3
STAT	Startup status and control program operational status
ACT	Ethernet network activity
LINK	Link established with Ethernet network

SNAP PAC R-Series Controllers—Network Interfaces and Ports

The following diagram applies to all SNAP PAC R-series controllers.

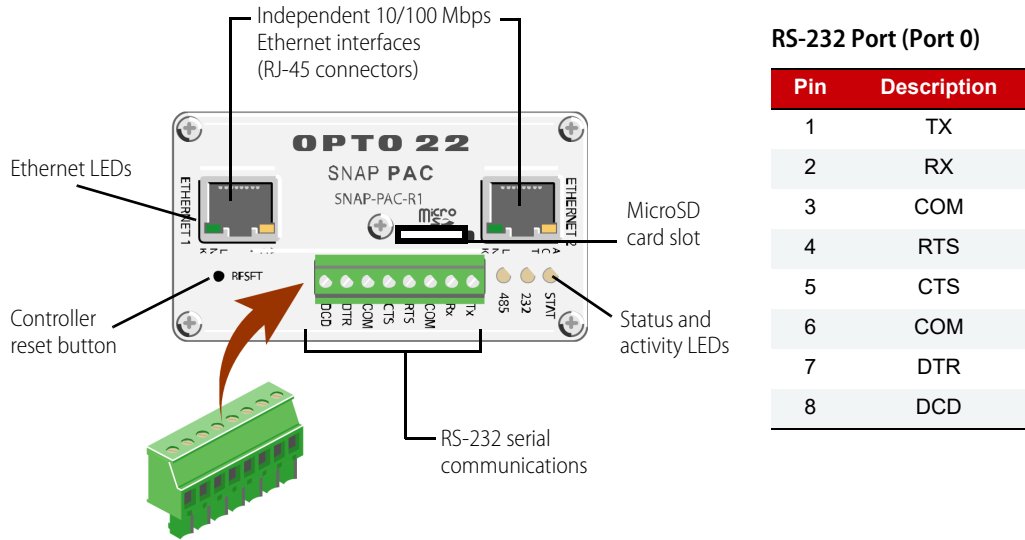

RS-232 Port (Port 0)

Pin	Description
1	TX
2	RX
3	COM
4	RTS
5	CTS
6	COM
7	DTR
8	DCD

Status and Activity LEDs

Indicator	Description
ACT	Ethernet network activity
LNK	Link established with Ethernet network
STAT	Startup status, control program operational status, MicroSD card access
232	RS-232 serial activity
PPP	PPP status

RS-232 Serial Cable Wiring*

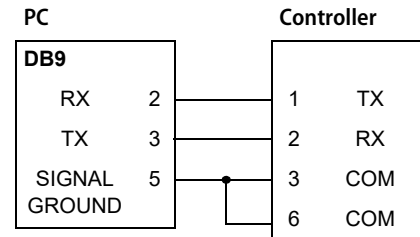

* Minimum requirements for an RS-232 connection. To connect the controller to a modem, see form #1595, the *SNAP PAC R-Series Controllers User's Guide*, for all eight pin connections.

SNAP PAC EB Brains—Interfaces

NOTE: All SNAP PAC EB brains are obsolete as of 2022. This diagram is retained here for reference.

This diagram applies to all versions of EB brains.

Switched Ethernet network interfaces

Brains can be networked in a daisy-chain configuration or in a standard star configuration using either Ethernet interface. Both interfaces use the same IP address.

NOTE: When using a daisy-chain configuration, be aware that if power to a brain is lost, all brains beyond it on the network will also lose communication. Firmware on daisy-chained brains must be updated one at a time.

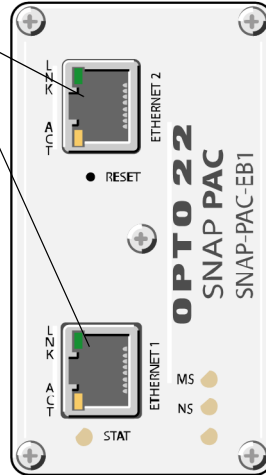

LEDs

LED	Indicates
LNK	Link established with Ethernet network
ACT	Activity on Ethernet network
STAT	Brain status
MS	EtherNet/IP Module Status
NS	EtherNet/IP Network Status
Unnamed	Reserved for future use

SNAP PAC SB Brains—Ports

LEDs

LED	Indicates
SERIAL	Green = Transmit Red = Receive Amber = Transmit/Receive
STAT	Brain status
IRQ	Reserved for future use

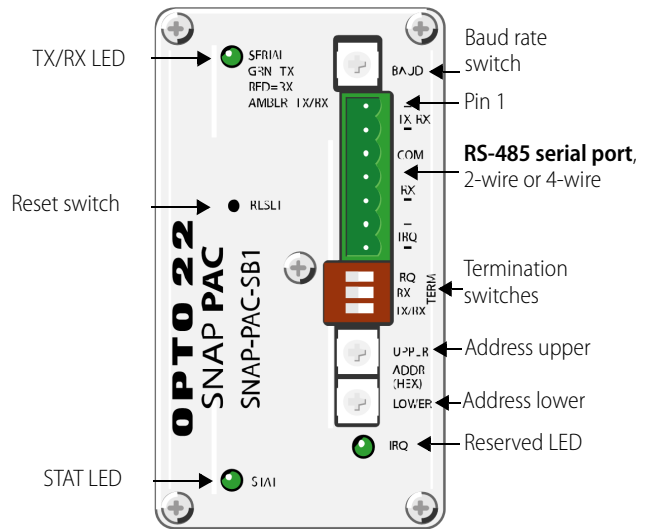

Bias is always ON.

ETHERNET NETWORKING OPTIONS

Standard Ethernet Network Usage

In an Ethernet network, SNAP PAC System controllers and EB brains (*obsolete as of 2022*) can be used just like any other device, and they are subject to exactly the same rules for physical connections and communication. SNAP PAC System devices communicate using TCP/IP and UDP/IP over standard Ethernet networks. (They can also communicate using Modbus[®]/TCP; for more information, see Opto 22 form #1678, the *Modbus/TCP Protocol Guide*.)

Most devices used on an Ethernet network have one network interface, an RJ-45 connector. But as shown in the previous diagrams, SNAP PAC controllers and EB brains each have two interfaces— two RJ-45 connectors. However, the two interfaces on controllers and brains are set up differently.

- **SNAP PAC Controllers**—The two interfaces on a SNAP PAC S-series or R-series controller are *independent* interfaces that have separate IP addresses and must be on separate networks or network subnets. To use the controller like any other Ethernet device, plug a Category 5 or newer cable into the connector marked *Ethernet 1*. You must use Ethernet 1, not Ethernet 2, because the controller sends a BootP request for an IP address from Ethernet 1 only.
- **SNAP PAC Brains** (*obsolete as of 2022*)—The two interfaces on SNAP PAC EB brains are *switched* interfaces that use the same IP address. To use the brain like any other device, plug a Cat 5 or newer cable into either connector. It doesn't matter which one you use.

For more information on networking SNAP PACs and *groov*, see [Guide to Networking Opto 22 Products](#), form #1796.

Alternatives to Standard Usage

While SNAP PAC controllers and brains can be networked as described using only one Ethernet interface— just like any other Ethernet device—their dual (or triple) interfaces also offer options for network design, which you may choose to use. In addition, SNAP PAC controllers and brains can communicate with both Modbus/TCP and Allen-Bradley[®] Logix[®] systems using EtherNet/IP. These options are discussed in the following sections.

Using Redundant Ethernet Network Links

Redundant network links help address the concern that an Ethernet network may fail or need maintenance, leaving the controller, the I/O units, and PCs (running PAC Display, OptoOPCServer, and OptoDataLink) unable to communicate.

SNAP PAC S-series and R-series controllers, used with PAC Project Professional, offer an option to address this concern. Each SNAP PAC controller has two independent Ethernet network interfaces. Because they are independent, each interface has a separate IP address. Redundant Ethernet links can be created using both interfaces on each device.

The following diagram shows an example. The SNAP PAC S-series controller is the main controller of the system, with SNAP PAC R-series controllers acting as distributed I/O processors. Each SNAP PAC controller is connected to two separate Ethernet network links, and each PC has two network interface cards (NICs) connected to the same links. In this configuration, if one link goes down, devices can still communicate on the other.

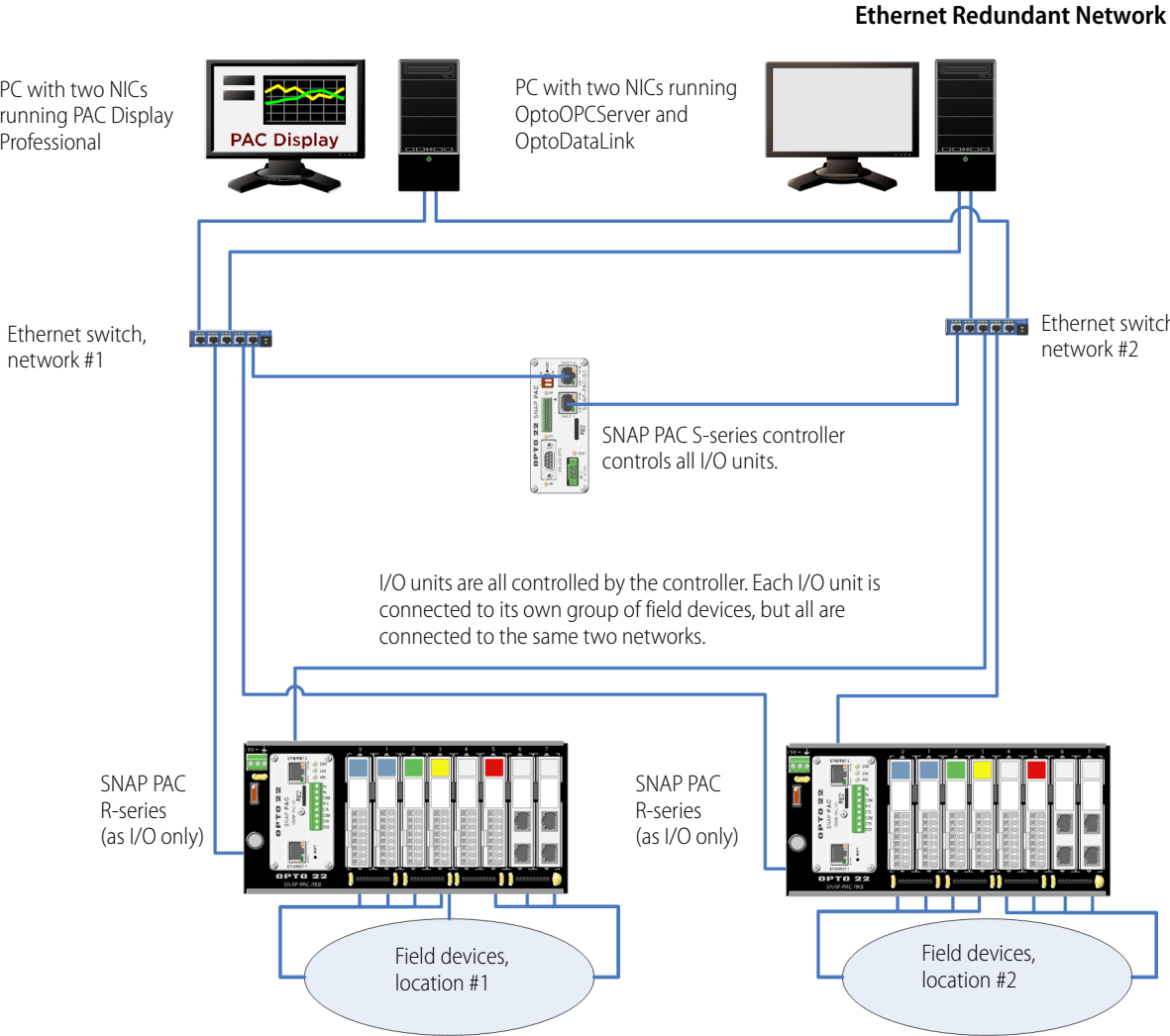

Isolating Ethernet Networks into Zones

Another concern with using Ethernet networks may be mixing control networks with enterprise computer networks. One answer is to isolate the two into separate zones so that they are not directly connected.

You can use either of two ways to isolate networks:

- Use separate Ethernet adapters in the computers you use for PAC Project, HMI, SCADA, and so on, using one NIC for the company network and the other for the control network. Then connect the PAC to the control network using only one of its Ethernet interfaces. (Learn more in [Networking SNAP PAC Products.](#))
- Use a *groov* EPIC processor instead of a SNAP PAC controller. Because EPIC has cybersecurity features that SNAP PACs do not, you can connect one EPIC interface to I/O units on the trusted control network and the other network interface to the untrusted computer network.

Communicating with Modbus/TCP Systems

All SNAP PAC controllers and brains can communicate natively using Modbus/TCP, a protocol for Modbus hardware and software on an Ethernet network.

The following diagram shows an Opto 22 system communicating with a Modbus system. In this example, the SNAP-PAC-S1 standalone controller runs a PAC Control strategy to monitor and control the I/O. Simultaneously, the Modbus system exchanges data with the Opto 22 system.

This example shows the Opto 22 control network segmented from the computer network: the PC is attached to Ethernet switch #1 and the control network is on Ethernet switch #2. Because the Modbus/TCP hardware is also on switch #2, it can send data to and from every I/O unit shown. The Modbus software running on the PC, attached to switch #1, can access data only from the controller; for instance, it might access data placed in the controller's Scratch Pad by the PAC Control strategy. The Scratch Pad is a large area within the controller's memory that stores binary data, floats, integers, and strings for peer-to-peer data exchange.

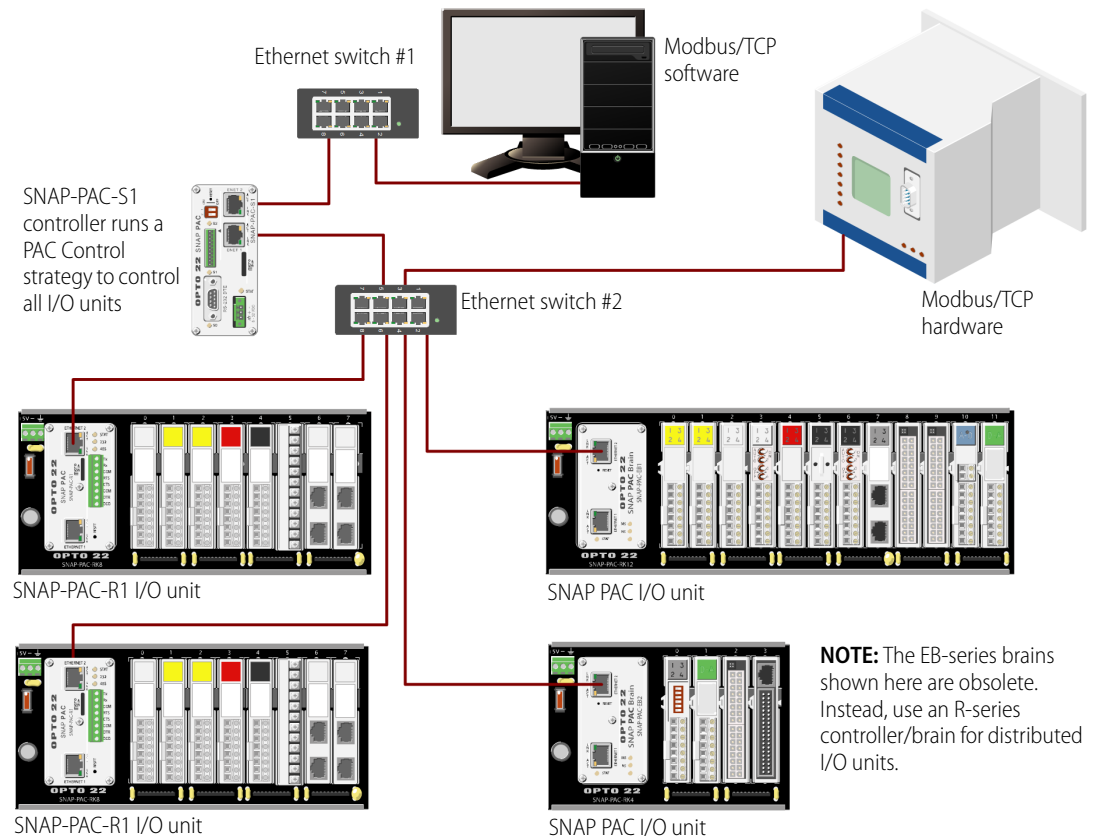

This is just one example; many other configurations are possible. If you are not using PAC Control, Modbus/TCP hardware or software on the same network segment as I/O units can provide full control for I/O points.

For details about communicating with Modbus/TCP systems, see Opto 22 form #1678, the *Modbus/TCP Protocol Guide*.

Communicating with Allen-Bradley PLC Systems

Because SNAP PAC controllers can also communicate natively with Allen-Bradley PLC systems based on the EtherNet/IP[®] protocol, including ControlLogix[®], CompactLogix[®], MicroLogix 1100/1400, and SLC 5/05, you can:

- Extend a PLC system using Opto 22 processors and I/O as intelligent, distributed I/O. In this case the processors provide distributed control, but supervisory control is left up to the PLC. See the white paper, *Expanding Allen-Bradley Systems with Distributed, Intelligent I/O* (form #1785).
- Exchange data between the SNAP PAC System and an Allen-Bradley system, as shown below. Any SNAP PAC controller running a PAC Control strategy can move variables and values to and from its Scratch Pad, and an A-B PLC system can read from or write to the Scratch Pad using EtherNet/IP. The Scratch Pad is a large area in the controller's memory that stores binary data, floats, integers, and strings for peer-to-peer data exchange.

In this example, the SNAP PAC is segmenting the two networks. Note that the N-TRON switches provide IGMP snooping, which is required for effective network traffic on EtherNet/IP.

Exchanging data between an A-B PLC system and a SNAP PAC System

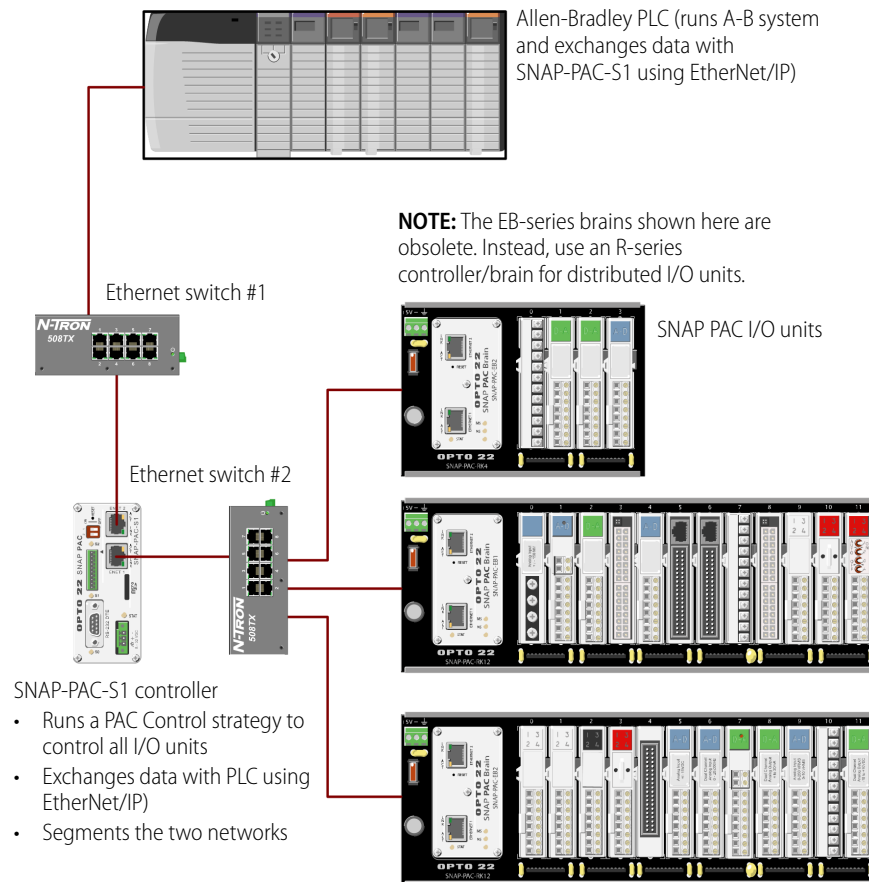

For detailed information on configuring I/O and communicating with A-B systems, see Opto 22 form #1909, the *IO4AB User's Guide*, and #1770, the *EtherNet/IP Protocol Guide*.

SERIAL NETWORK OPTIONS

Although the SNAP PAC System is an Ethernet-based control system, it provides serial network options for connecting to hosts, distributed I/O, and other serial devices.

- You can connect to distributed SNAP PAC Serial Brains and I/O ([page 50](#)).
- You can communicate with any RS-232 or RS-485 serial device, such as chart recorders, RFID and barcode readers, printers, and scales ([page 50](#)).
- You can communicate with a remote host over a modem (see [page 50](#)).
- You can connect to legacy Opto 22 serial *mistic* I/O (see [page 51](#)).

Using Distributed Serial I/O

If all or a portion of your control system needs to be on a serial link, SNAP PAC **SB** brains provide the distributed serial I/O. Note that SB brains must be used with a SNAP PAC S-series controller, which has RS-485 ports. The SNAP-PAC-S1 has one RS-485 port; the SNAP-PAC-S2 has four serial ports, any number of which can be software configured for RS-485.

Use either PAC Project Basic or Professional with the S-series controller and SB brains. Configuration and programming are the same as for Ethernet (EB) brains.

Serial communication parameters (baud rate, address, termination) for SB brains are set on the brain's top cover. See "[Setting Up Serial Networking](#)" on [page 56](#) for details.

Connecting Directly to Serial Devices

The serial ports on SNAP PAC R-series and S-series controllers can also be used for direct connection to serial devices. For types and number of ports on each controller, see the diagrams starting on [page 42](#).

Typical serial devices you might connect to include printers, scales, chart recorders, and RFID and barcode systems. Using the controller's ports, you can control, monitor, and collect data from these types of devices using the PAC Control strategy (either Basic or Professional).

For locations away from the controller, you can use SNAP serial communication modules on distributed I/O. Serial modules snap on a mounting rack alongside analog and digital modules to provide the serial connections needed at distributed locations. RS-232 modules include RTS/CTS. RS-485 modules offer either 2-wire or 4-wire mode. Each module offers two serial ports (one port if you use an RS-485 in 4-wire mode). Up to eight serial modules can be placed on a single rack.

Communicating with a Remote Host Using a Modem

For remote monitoring and control, you can use an RS-232 serial port on a SNAP PAC R-series or S-series controller to connect to a remote host such as a PC using a dial-up link. Like a remote telemetry unit (RTU), the controller communicates over a modem, as shown below, using the Point-to-Point Protocol (PPP).

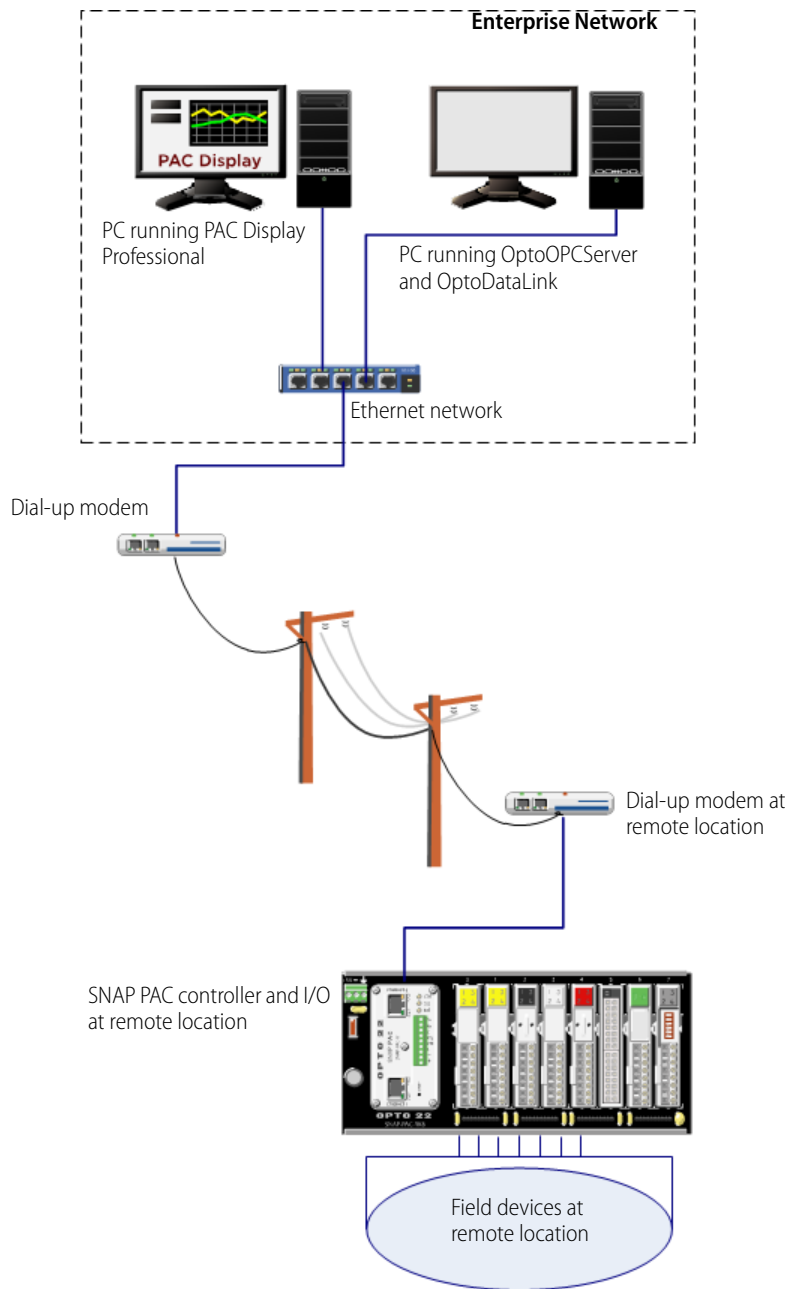

Communicating with Legacy Serial *mistic* I/O Units

Using a SNAP PAC S-series controller and PAC Project Professional, you can incorporate older serial *mistic* systems into the SNAP PAC System, simultaneously communicating with legacy serial I/O units (such as serial B3000 brains and *mistic* bricks), as well as serial and Ethernet SNAP PAC I/O units.

For large numbers of serial I/O, use a SNAP-PAC-S2 controller, which has four serial ports that are all software configurable for RS-485.

In the following diagram, a SNAP PAC controls multiple Opto 22 serial-based I/O units over an RS-485 serial network. The controller also communicates with a separate enterprise Ethernet network to provide process data to a PC running Opto 22's PAC Display HMI software.

SERIAL NETWORK OPTIONS

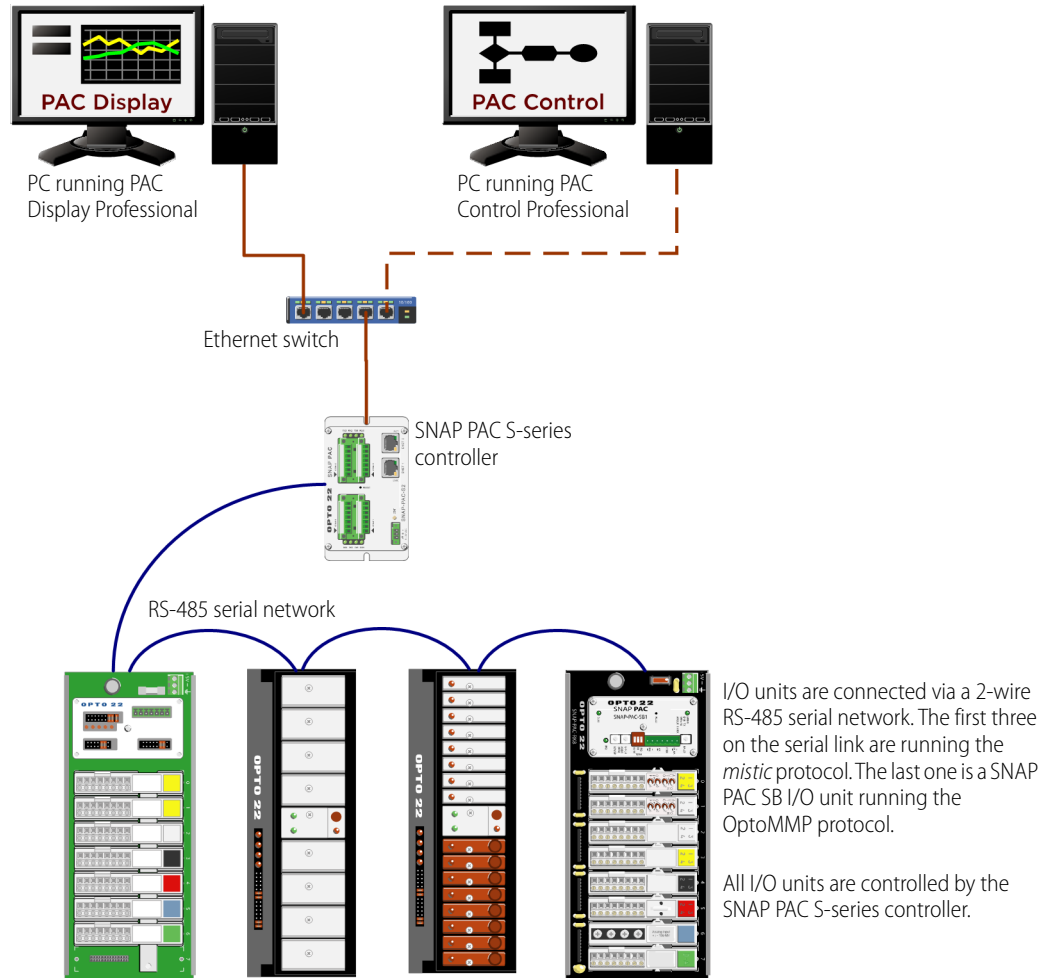

4: Installing and Wiring System Components

INTRODUCTION

This chapter shows you how to install SNAP PAC System components and connect them to field devices. This chapter includes basic information; always consult the component's user guide or data sheet for more details on installation and wiring.

DOWNLOADING AND INSTALLING SOFTWARE

The software used with the SNAP PAC System is the PAC Project software suite. The suite can be downloaded from our website, www.opto22.com. All PAC Project software, both Basic and Professional, is in one single download, and full documentation is included in Adobe Acrobat PDF format.

You can install the Basic version right away to get started. Once you've downloaded the file from our website, just double-click the file to open it and run the installer.

To install PAC Project Professional or any title within the suite, first purchase the product through our distribution channel, online, or by calling Opto 22 Sales at (800) 321-6786 or (951) 695-3000. When you have your password, run the installation again. Choose PAC Project Professional or the software titles you purchased, and enter your password. All software and documentation are included in the download.

Firmware

Make sure you use firmware for all SNAP PAC controllers and brains that matches your version of PAC Project software applications. Firmware is updated often to match new software versions or support new modules.

The most recent firmware is always available on our website. Simply download the firmware file and follow instructions in the *PAC Manager User's Guide* (form #1704) to install it.

MOUNTING CONTROLLERS

SNAP PAC S-series controllers can be either panel mounted or DIN-rail mounted. For DIN-rail mounting, purchase the optional DIN-rail mounting kit (see [page 40](#) for compatible kits). Follow directions in the controller user's guide to mount it.

SNAP PAC R-series controllers mount on a SNAP PAC rack with the I/O modules. For mounting instructions, see the next section.

INSTALLING I/O PROCESSORS AND I/O MODULES

SNAP I/O modules and SNAP PAC brains and rack-mounted controllers are installed on SNAP PAC racks. Each rack mounts one processor and up to 4, 8, 12, or 16 modules. The modules can be any combination of SNAP I/O modules— analog, digital, and serial. Serial modules cannot be used with serial brains and are limited to a maximum of 8 on any one rack.

Installing I/O Modules

Modules snap into place in the row of connectors on the rack. Each module connector has a number.

1. Assemble the rack according to the directions that came with it.
2. Place the rack so that the module connector numbers are right-side up, with zero on the left.

A four-module rack is shown below as an example.

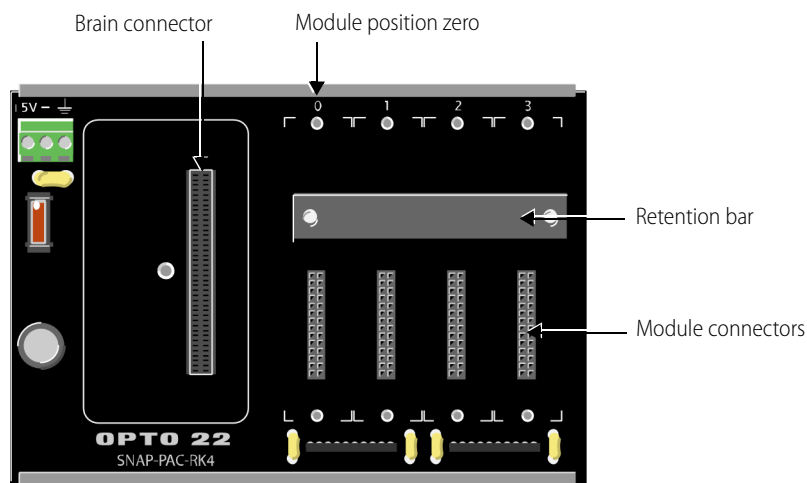

3. Position the module over the module connector, aligning the small slot at the base of the module with the retention bar on the rack.

4. With the module correctly aligned over the connector, push on the module to snap it into place.

When positioning modules next to each other, be sure to align the male and female module keys (shown in the detailed view in the illustration at right) before snapping a module into position.

Modules snap securely into place and require a special tool (provided) for removal. To remove a module, see the next section.

5. Use standard 4-40 x 1/2 truss-head Phillips hold-down screws to secure both sides of each module.

CAUTION: Do not over-tighten screws.
Recommended torque: 4 in-lb (0.45 N-m)

6. Plug the wiring connector into each module to attach modules to the devices they monitor. Follow wiring diagrams beginning on [page 61](#) or in the module data sheets. (See [page 12](#) for a list of data sheets.)

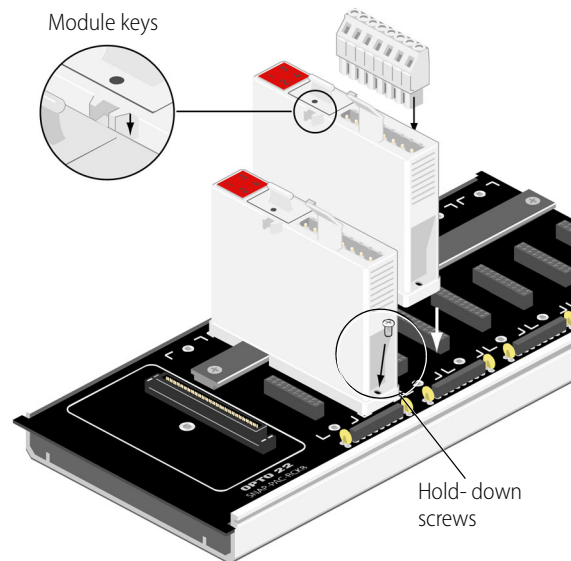

Removing a Module

1. Remove the module's two hold-down screws.
2. Holding the SNAP module tool (provided) as shown in the illustration at right, insert it into the notch at the base of the module.
3. Squeeze the module tool against the module to open the release latch, and pull straight up on the module to remove it.

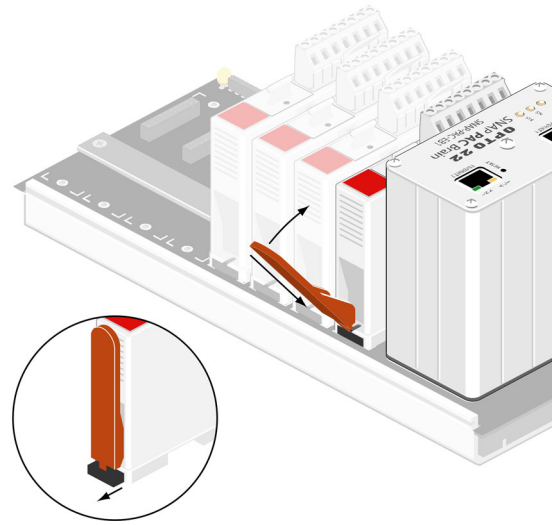

Installing the Brain or Rack-Mounted Controller

1. Remove the processor from its packaging.
2. Turn off power to the rack assembly.
3. Align the processor's connector with the mating connector on the mounting rack.
4. Seat the processor onto the connector and use the hold-down screw to secure it in position. Do not overtighten.
5. To attach network cabling and configure addressing, skip to one of the following:
 - ["Setting Up Ethernet Networking,"](#) below.
 - ["Setting Up Serial Networking" on page 56.](#)

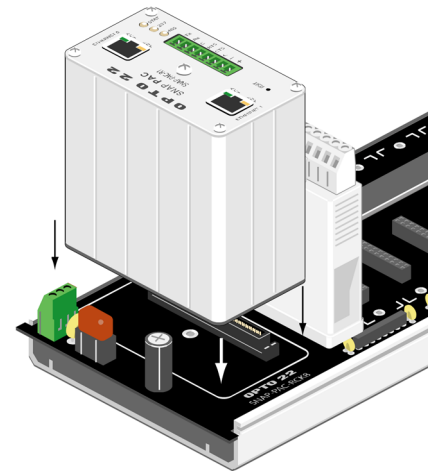

Setting Up Ethernet Networking

1. For an Ethernet-based I/O processor, use Category 5 or superior solid unshielded twisted-pair cable to connect the processor in one of the following ways:
 - (Recommended for initial configuration) Connect to a PC directly, using any standard Ethernet cable. (The Ethernet interface(s) on this product support Auto MDI-X; a crossover cable is not needed for direct connection to a PC.)
 - Connect to a standard 10BASE-T or 100BASE-TX Ethernet network that has a PC on the same subnet as the brain and does NOT have a Dynamic Host Configuration Protocol (DHCP) server. Maximum cable or segment length is 100 meters; minimum cable length is one meter.
2. **Before turning on power** to the processor, read instructions in the *PAC Manager User's Guide* and assign the IP address.

Setting Up Serial Networking

Follow the SB brain diagram on [page 45](#) and the steps below to set up serial networking for SB brains and an S-series controller.

1. Attach an RS-485 serial cable to the serial port.
2. Rotate the baud rate switch to set the desired baud rate:

Baud rate	Switch position	Baud rate	Switch position
(Reserved)	F	4800 bps	7
230400 bps	E	2400 bps	6
115200 bps	D	1200 bps	5
76800 bps	C	600 bps	4
57600 bps	B	300 bps	3
38400 bps	A	(Reserved)	2
19200 bps	9	(Reserved)	1
9600 bps	8	(Reserved)	0

Baud Rate Switch

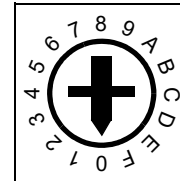

3. Use the three tiny termination switches to set termination:
 - For half-duplex termination (2-wire 485), move switch 1 (TX/RX) to ON and switch 2 (RX) to OFF.
 - For full-duplex termination (4-wire 485), move switch 1 to ON and switch 2 to ON (illustrated at right)

NOTE: Bias on a SNAP PAC SB brain is always ON.

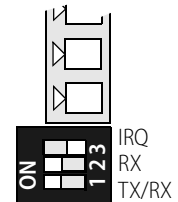

(Switch 3 is reserved.)

4. Use the two 16-position rotary address switches to set the unit's address. There are 256 possible addresses, 0–255. If you need help setting the address switches, see the brain user's guide.
5. Wire and terminate the serial link as shown in the following diagrams.

Wiring a SNAP PAC SB-Series Brain to any SNAP-PAC-S1 Controller

Two-wire

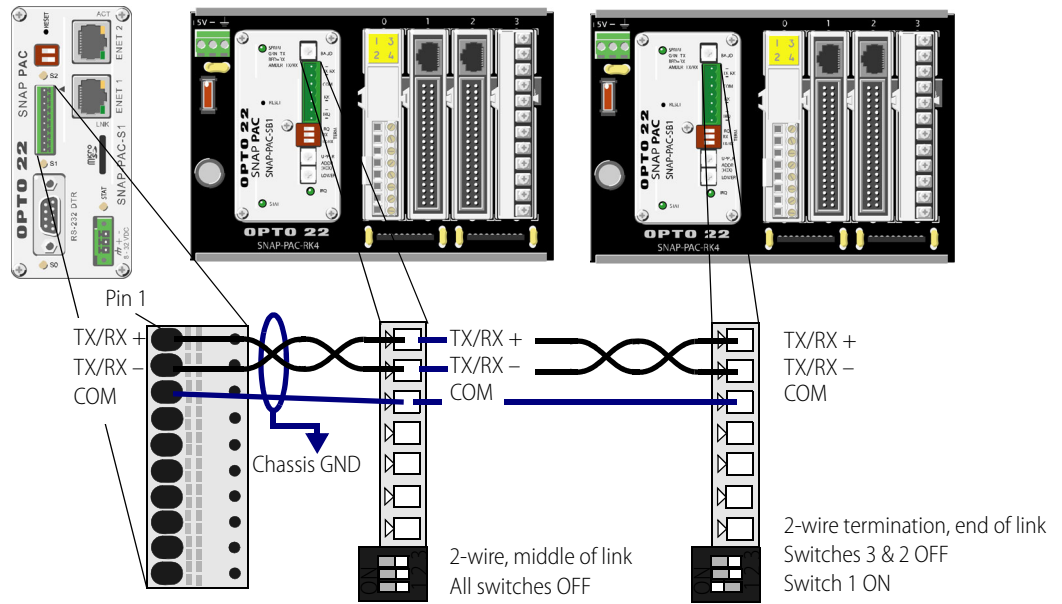

Wiring a SNAP PAC SB-Series Brain to any SNAP-PAC-S2 Controller

Two-wire

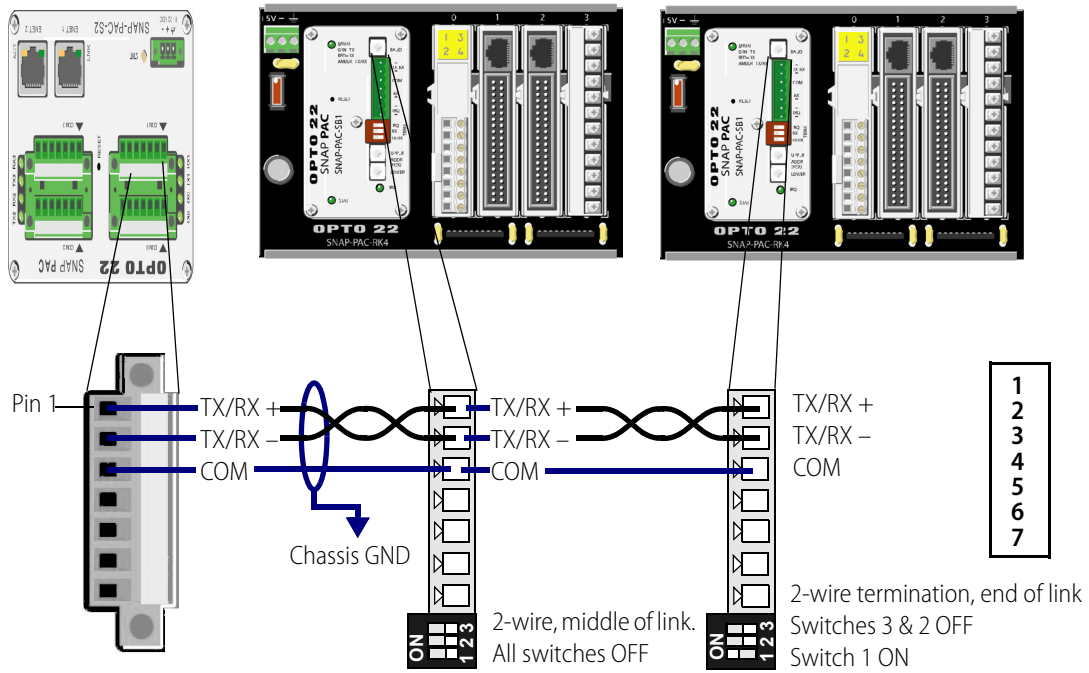

Four-wire

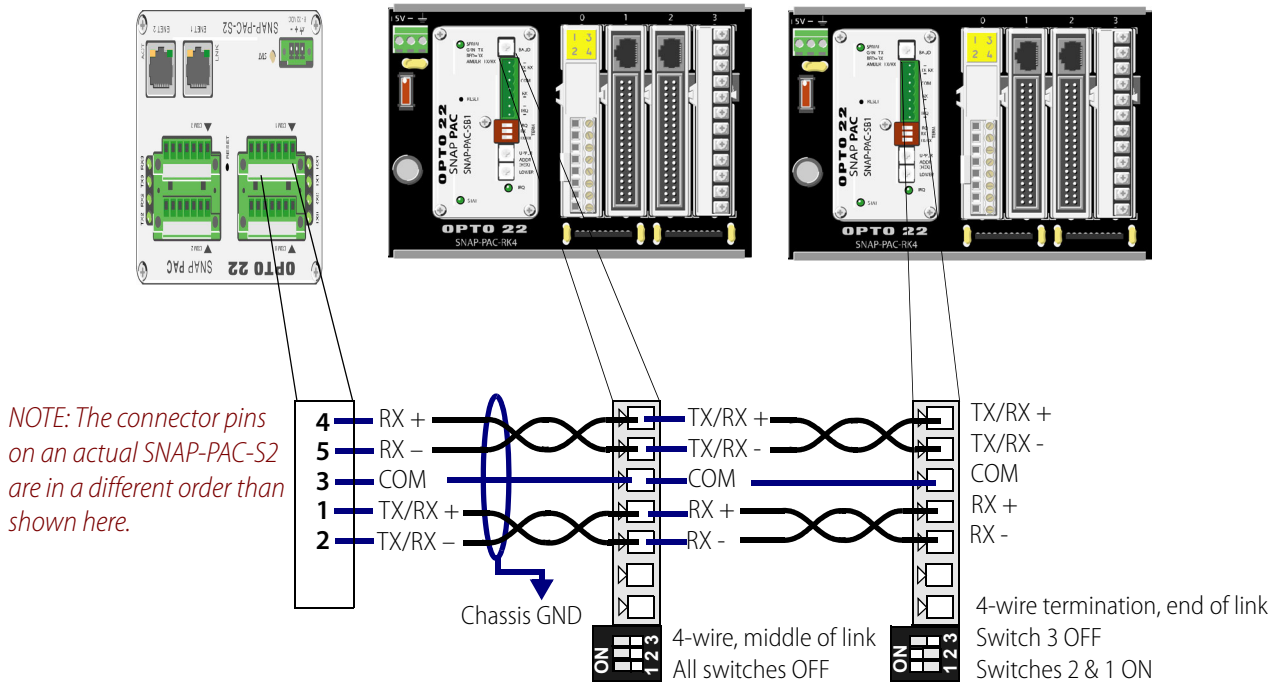

WIRING POWER SUPPLIES

Primary Power Supply

Use one power supply per I/O unit. Use 14 AWG wire.

1. Mount the SNAP-PS5 or SNAP-PS5-24DC power supply so that the attached red and black power wires will reach the + and – power terminals on the SNAP mounting rack.
2. Using the power terminals on the SNAP PAC rack, attach the red wire to the + terminal and the black wire to the – terminal. Connect the ground terminal on the rack to ground.
3. For the **SNAP-PS5** (not illustrated): Using the removable input power connector on top of the power supply, apply 120 volts AC power between the two terminals marked “AC.” Connect the ground terminal to ground.
4. For the **SNAP-PS5U** (not illustrated): Using the removable input power connector on top of the power supply, apply 240 or 120 volts AC power between the two terminals marked “AC.” Connect the ground terminal to ground.
5. For the **SNAP-PS5-24DC** (illustrated below): Using the removable input power connector on top of the power supply, apply 24 volts DC power between the two terminals marked “±DC.” Connect the ground terminal to ground.

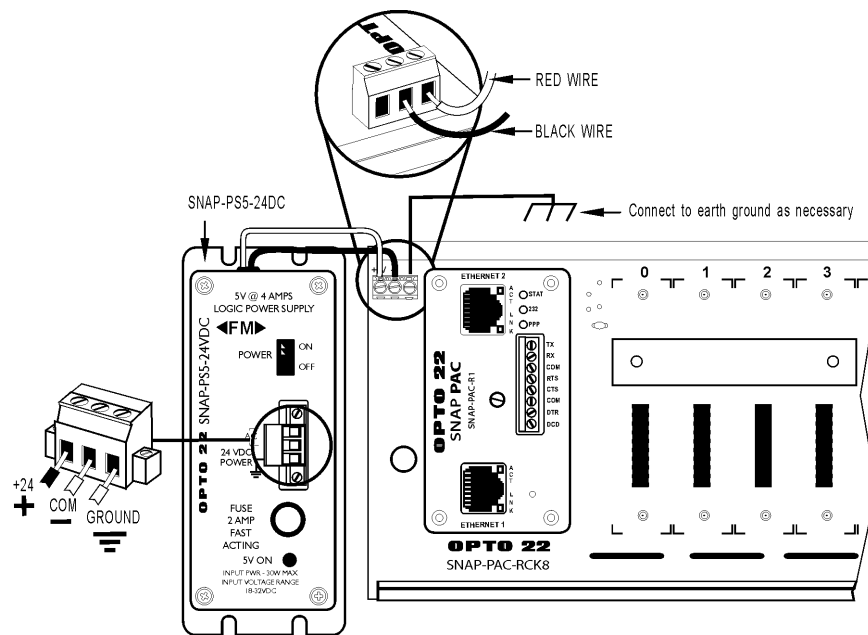

Loop Power Supply

Some analog modules (such as the SNAP-AIMA and SNAP-AIMA-i) also require a current loop supply, which can be provided by the SNAP-PS24 or the SNAP-PS24U. Both offer 24 volts of DC power, the SNAP-PS24 at 0.75 A and the SNAP-PS24U at 1.25 A. Follow these steps to wire these power supplies.

1. Mount the SNAP-PS24 or SNAP-PS24U power supply in a location where the attached output power wires will reach the field connector for SNAP analog modules.
The white and red wire is the positive wire (24 VDC). The white and black wire is the negative wire (24 VDC return).
2. If you are wiring directly to the module, see the wiring diagram for the specific module you are using.

Examples for an input module are shown in the following diagrams.

SNAP-PS24

In this diagram, the SNAP-PS24 power supply supplies power directly to the input module. The SNAP-PS5 supplies power to the rack.

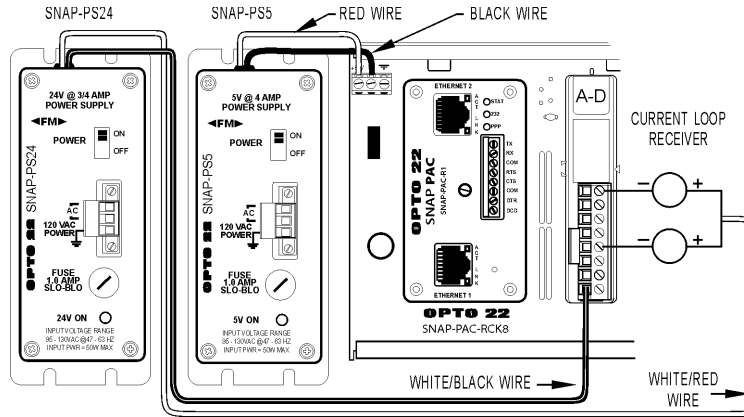

SNAP-PS24U

Here, the SNAP-PS24U power supply supplies power directly to the input module. The SNAP-PS5U supplies power to the rack.

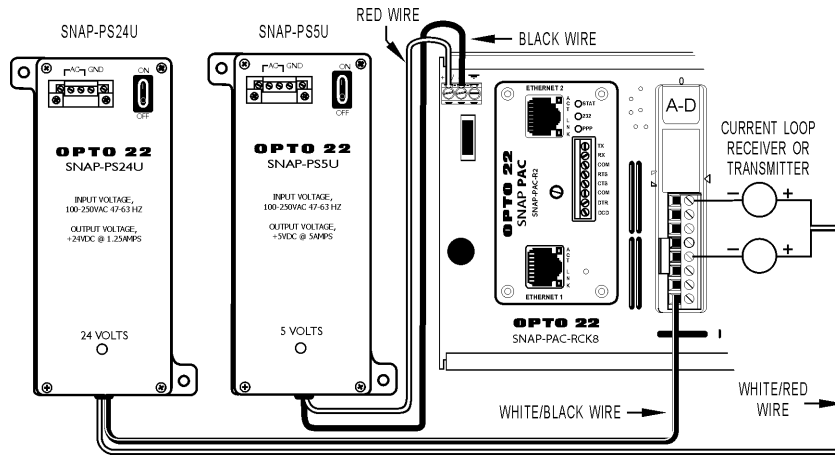

WIRING I/O MODULES

See additional diagrams for wiring modules and field devices to SNAP TEX breakout boards in the *SNAP TEX Cables and Breakout Boards Data Sheet*, form 1756.

4-Channel Digital Input Modules

For high-density digital modules, see [page 68](#).

Wiring for most 4-channel digital input modules (except SNAP-IDC5-SW and SNAP-IDC5-SW-NC).

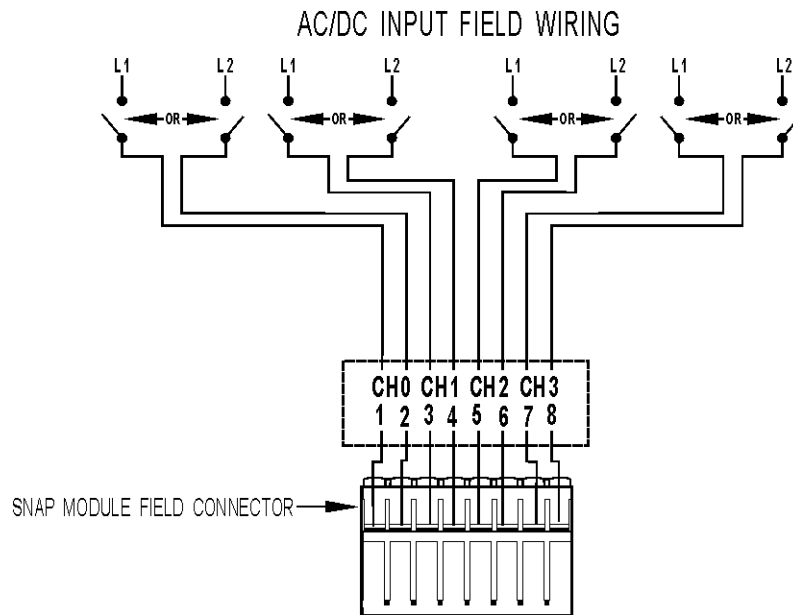

Wiring for SNAP-IDC5-SW and SNAP-IDC5-SW-NC digital input modules.

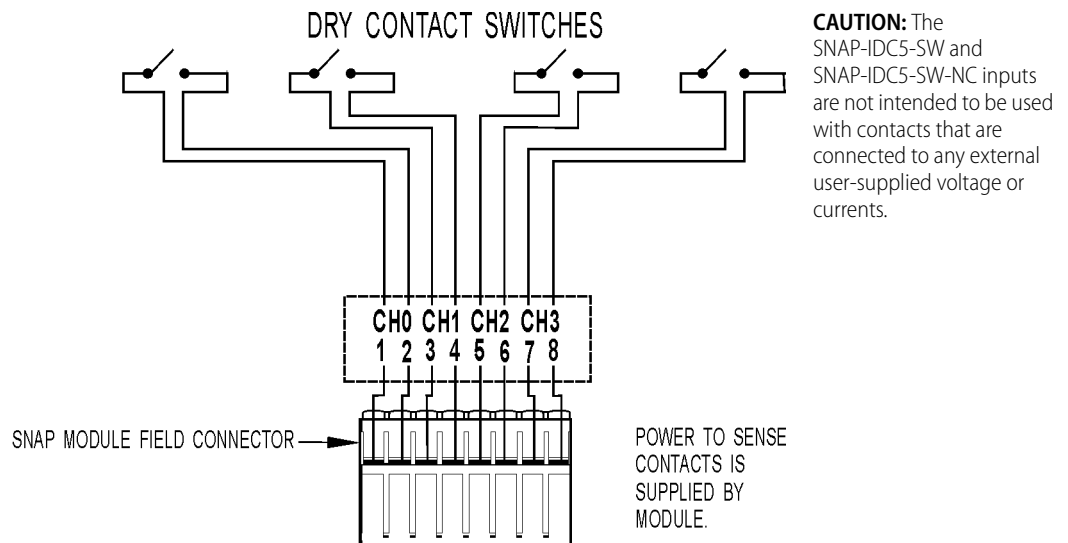

Wiring for SNAP-IDC5Q quadrature input module.

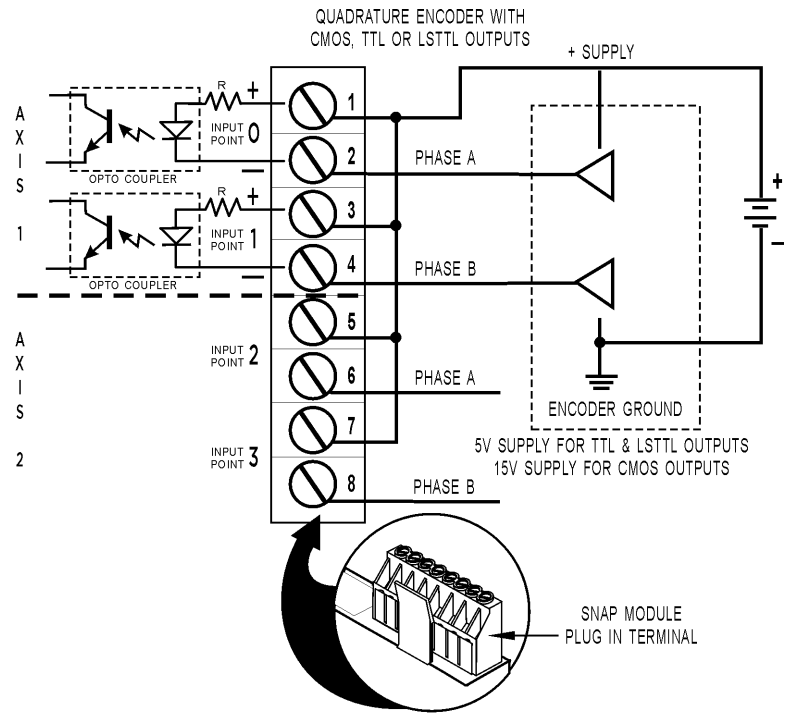

ALL INPUTS ARE ISOLATED FROM EACH OTHER
AND DO NOT SHARE ANY COMMON CONNECTIONS INTERNALLY.

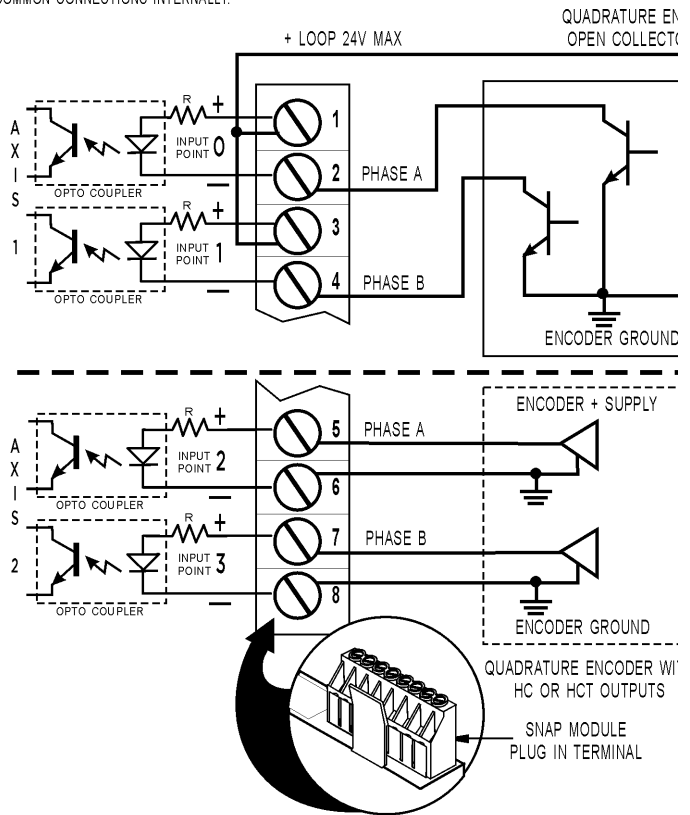

ALL INPUTS ARE ISOLATED FROM EACH OTHER
AND DO NOT SHARE ANY COMMON CONNECTIONS INTERNALLY.

4-Channel Digital Output Modules

For high-density digital modules, see [page 68](#).

Wiring for SNAP-OAC5 digital AC output moduls.

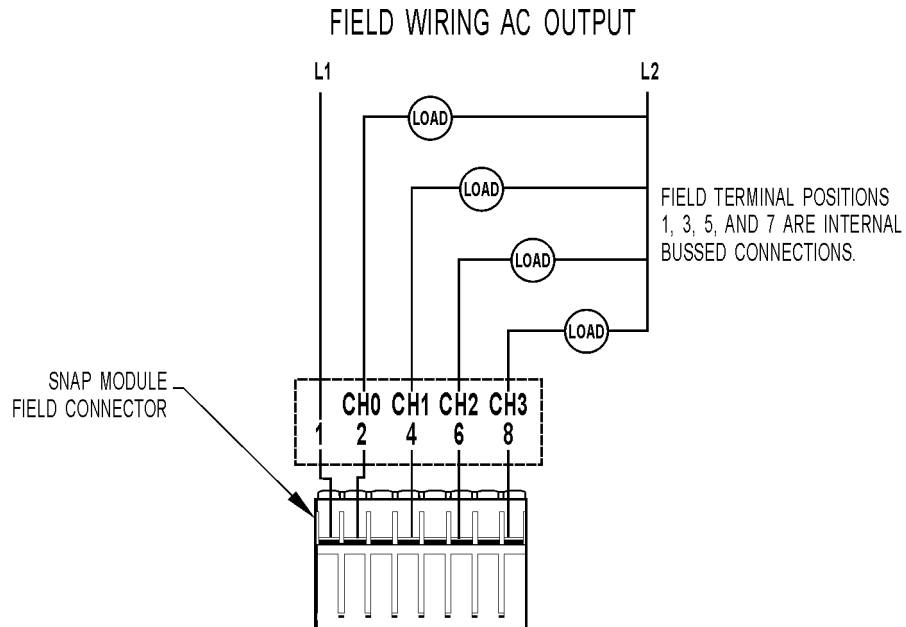

Wiring for SNAP-OAC5MA and SNAP-OAC5-i digital AC output modules.

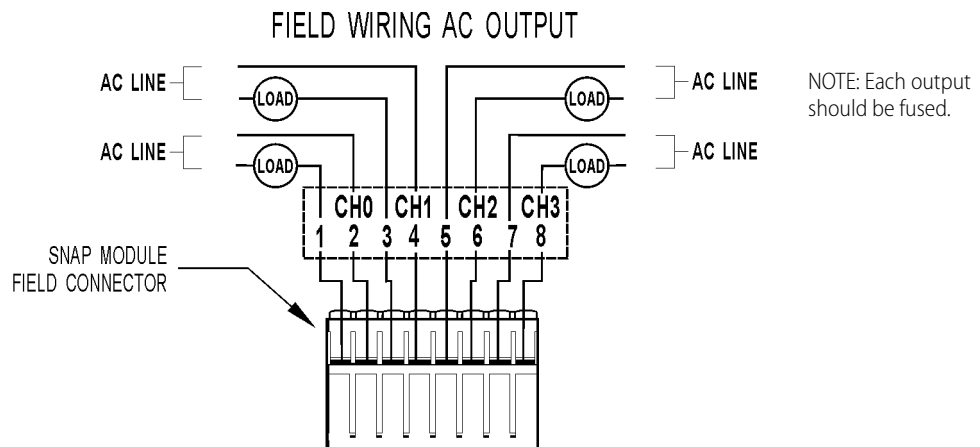

Wiring for SNAP-ODC5SRC and SNAP-ODC5SRCFM digital DC output modules.

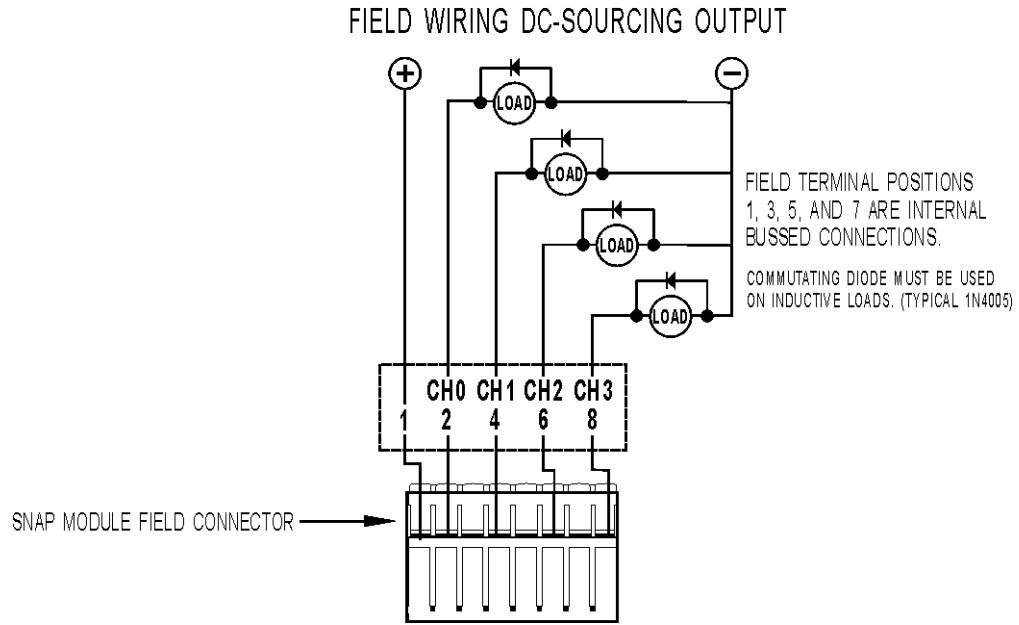

Wiring for SNAP-ODC5SNK, SNAP-ODC5ASNK, and SNAP-ODC5SNKFM digital DC output modules.

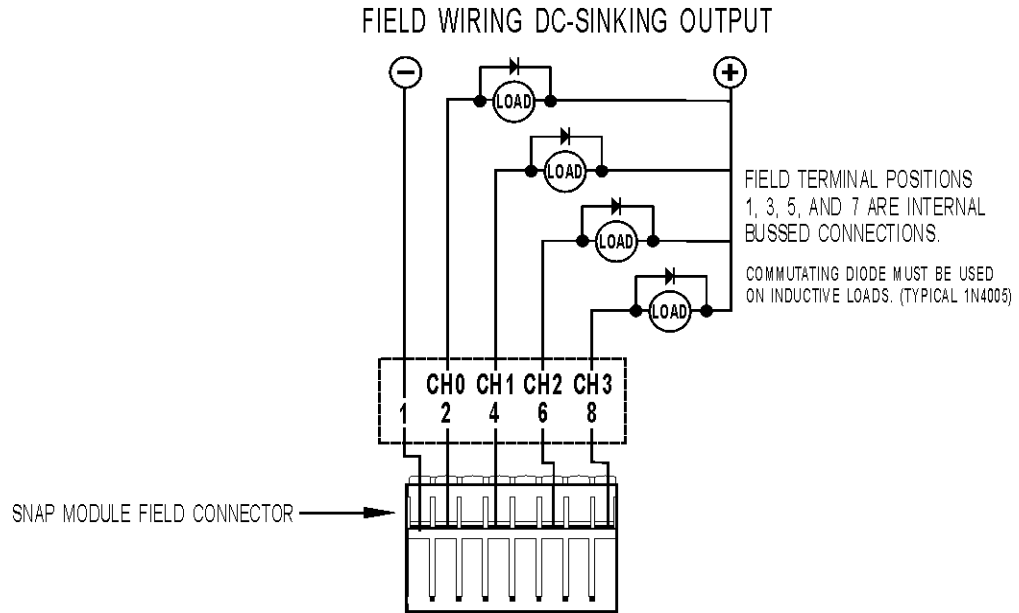

Wiring for SNAP-ODC5R, SNAP-ODC5R5, and SNAP-ODC5RFM dry contact output modules.

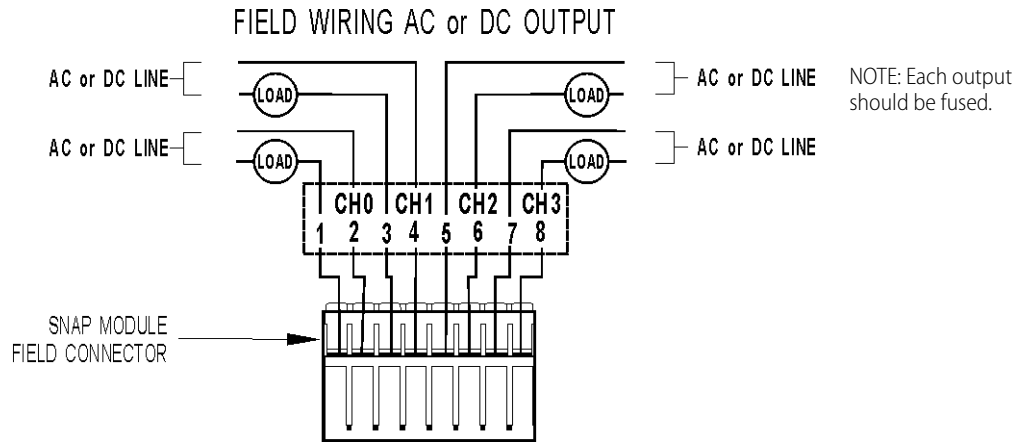

Wiring for SNAP-ODC5MA digital DC output module with manual/auto switches.

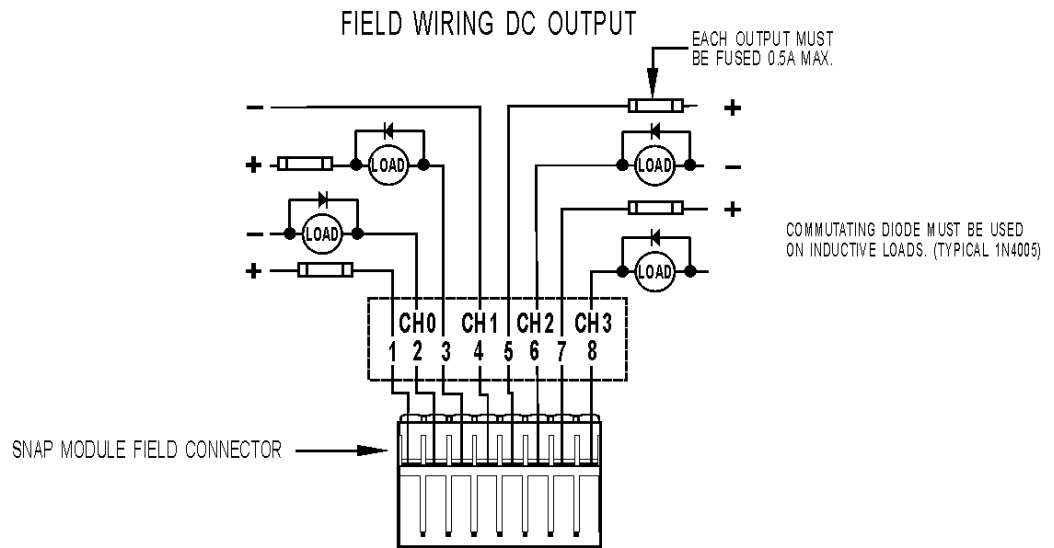

Wiring for SNAP-ODC5-i, SNAP-ODC5A-i, and SNAP-ODC5-iFM isolated digital DC output modules.

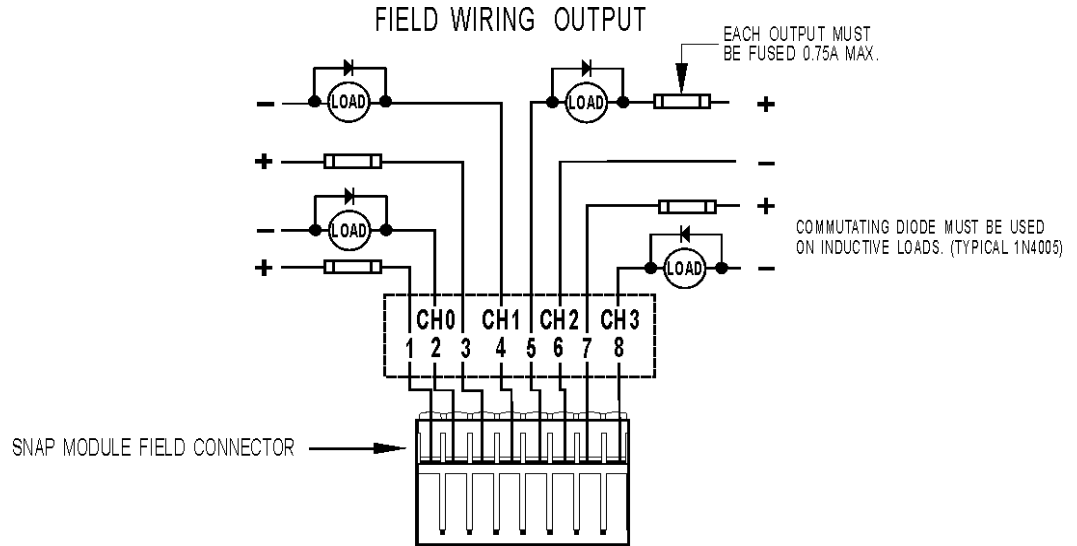

Wiring for SNAP-OMR6T-C mechanical power relay output modules.

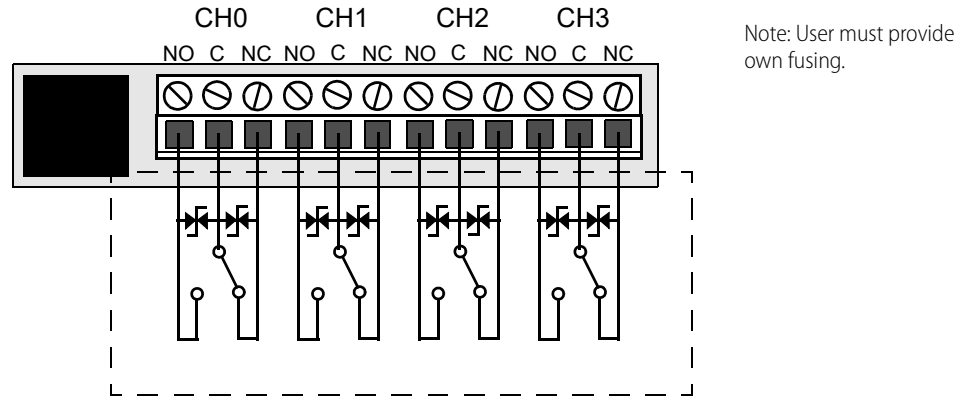

NOTE: External transient protection is recommended for highly inductive loads.

Wiring for SNAP-OMR6-C mechanical power relay output modules.

SNAP-OMR6-C Field Connections: Newer Terminal (gray)

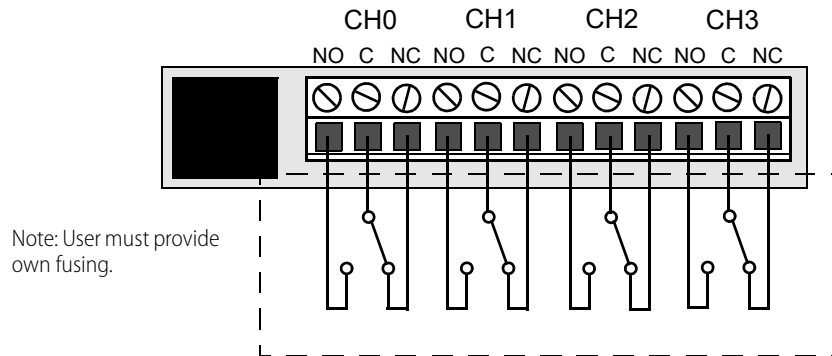

*NOTE: Transient protection is recommended for inductive loads.
NOTE: For DC loads, install a reverse-biased diode, such as an 1N4005 (or equivalent) at the load.*

SNAP-OMR6-C Field Connections: Older Terminals (black)

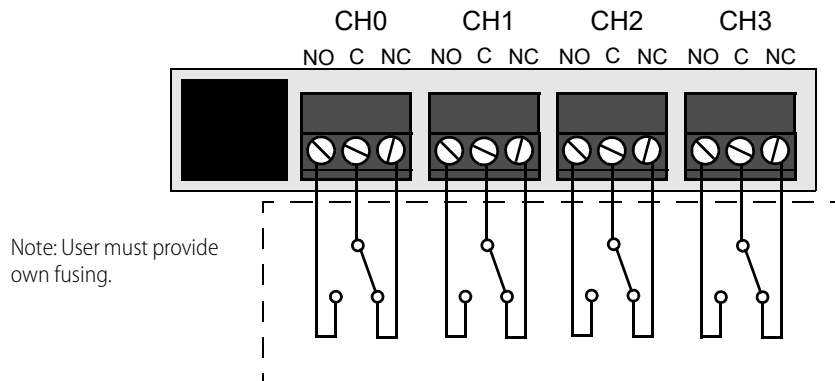

*NOTE: Transient protection is recommended for inductive loads.
NOTE: For DC loads, install a reverse-biased diode, such as an 1N4005 (or equivalent) at the load.*

High-Density Digital Modules

Wiring for SNAP-IDC-16, SNAP-IDC-HT-16, and SNAP-IAC-16 digital input modules.

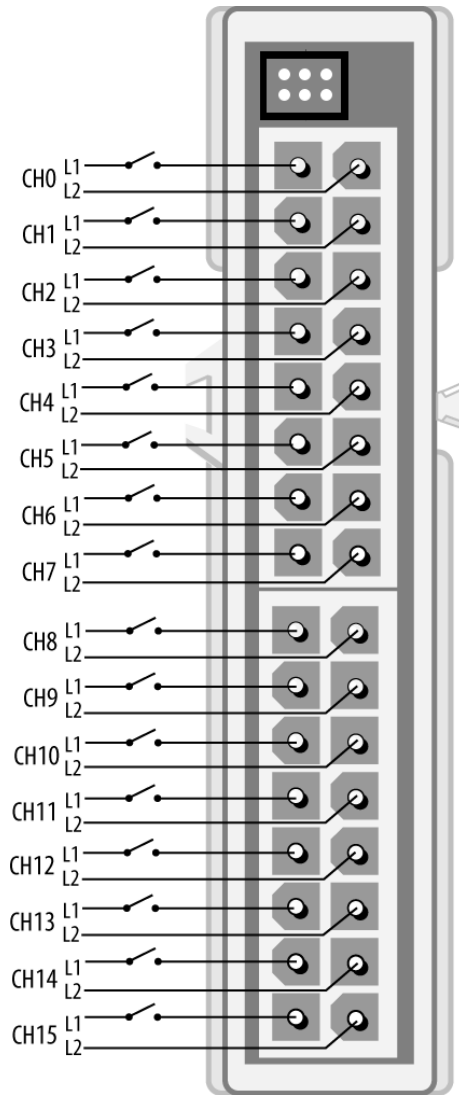

NOTE: The connectors on these modules are not polarity-sensitive. You can connect the positive lead (+) for each channel (or point) to either L1 or L2, and this can vary from point to point on the module.

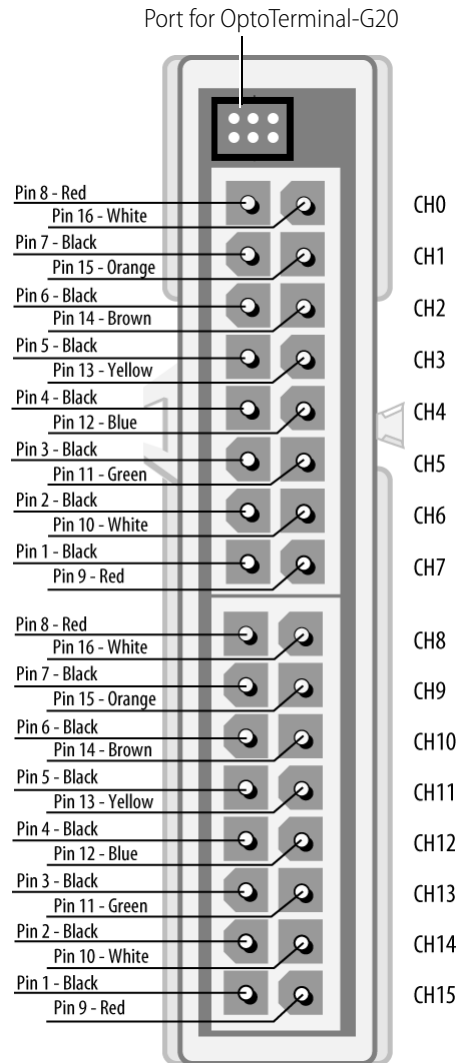

NOTES: The small four-pin connector on the top of the 16-point module connects to the optional OptoTerminal-G20 using a special adapter cable, included with the OptoTerminal.

The connectors on these modules are not polarity-sensitive. You can connect the positive lead (+) for each channel (or point) to either L1 or L2, and this can vary from point to point on the module.

See Opto 22 form 1547, the *SNAP High-Density Digital Module User's Guide*, for breakout rack wiring and jumper settings for the SNAP-IDC-HDB and SNAP-ODC-HDB and their -FM versions.

Wiring for high-density digital connector used with 32-channel input and output modules.

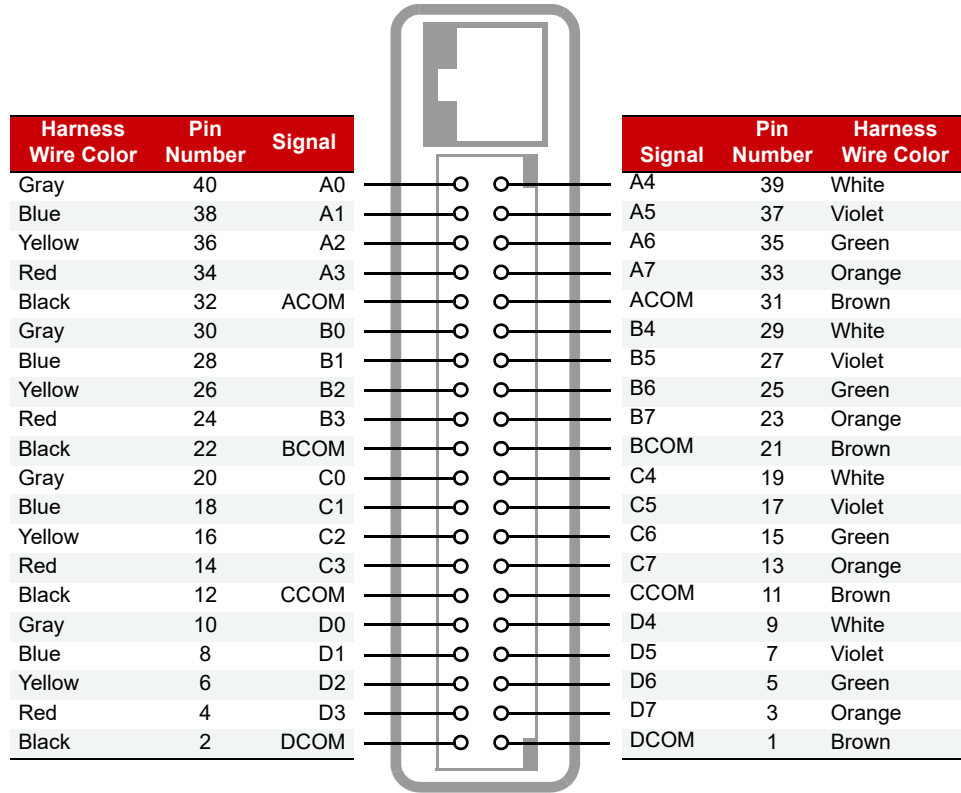

Connector wiring for SNAP-ODC-32-SNK, SNAP-ODC-32-SRC, SNAP-IDC-32, -FM versions, SNAP-IDC-32N, and SNAP-IDC-32DN (top view of module)

The following table shows 32-channel module connector wiring for the **SNAP-HD-CBF6** wiring harness. Wires from the wiring harness are grouped into four sets of color-coded wires. Use this table with the diagram above..

Set A			Set B			Set C			Set D		
Wires		Ch	Wires		Point	Wires		Point	Wires		Ch
A0	Gray	0	B0	Gray	8	C0	Gray	16	D0	Gray	24
A1	Blue	1	B1	Blue	9	C1	Blue	17	D1	Blue	25
A2	Yellow	2	B2	Yellow	10	C2	Yellow	18	D2	Yellow	26
A3	Red	3	B3	Red	11	C3	Red	19	D3	Red	27
A4	White	4	B4	White	12	C4	White	20	D4	White	28
A5	Violet	5	B5	Violet	13	C5	Violet	21	D5	Violet	29
A6	Green	6	B6	Green	14	C6	Green	22	D6	Green	30
A7	Orange	7	B7	Orange	15	C7	Orange	23	D7	Orange	31

For additional information, see form #1547, the *SNAP High-Density Digital Module User's Guide*.

Wiring for SNAP-IDC-32, SNAP-IDC-32-FM, and SNAP-IDC-32N high-density digital inputs.

Also see wiring for connector on [page 70](#).

IMPORTANT: All SNAP-IDC-32 modules are polarity specific and must be wired as shown.

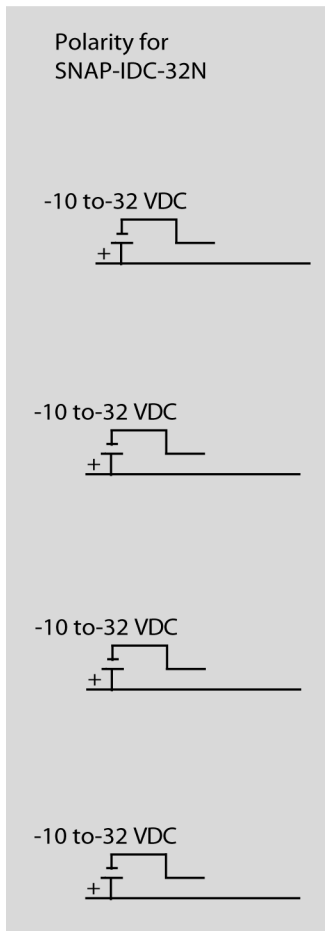

**Polarity for SNAP-IDC-32
SNAP-IDC-32-FM**

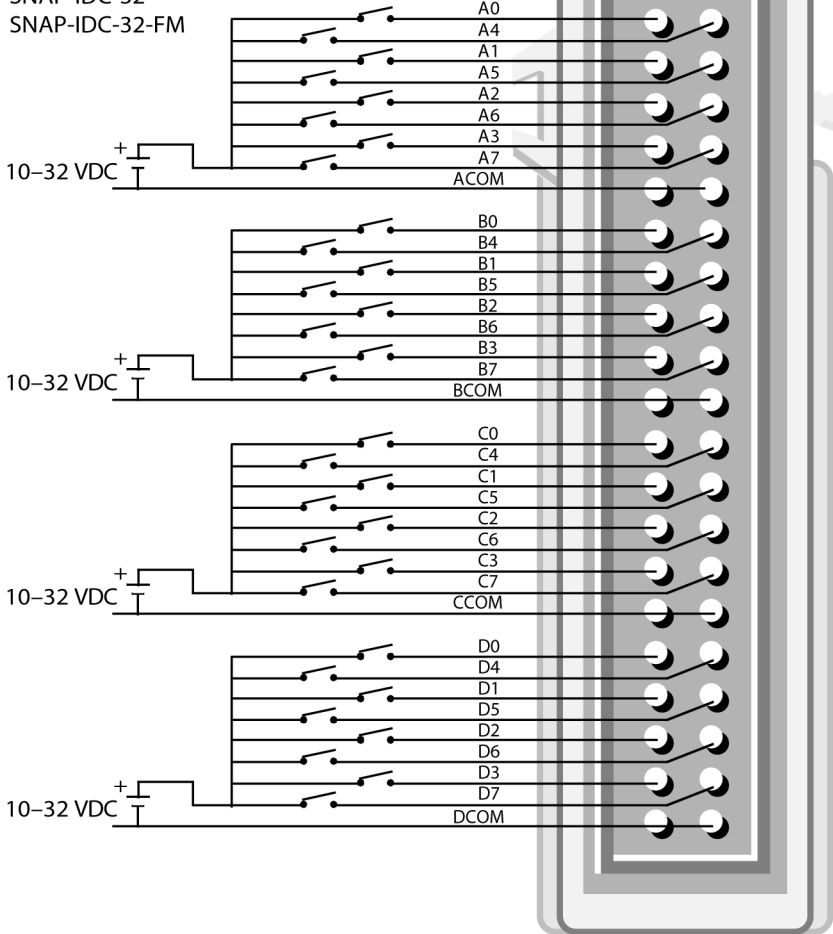

Wiring for SNAP-IDC-32D and SNAP-IDC-32DN high-density digital inputs.
 Also see wiring for connector on [page 70](#).

IMPORTANT: All SNAP-IDC-32 modules are polarity specific and must be wired as shown.

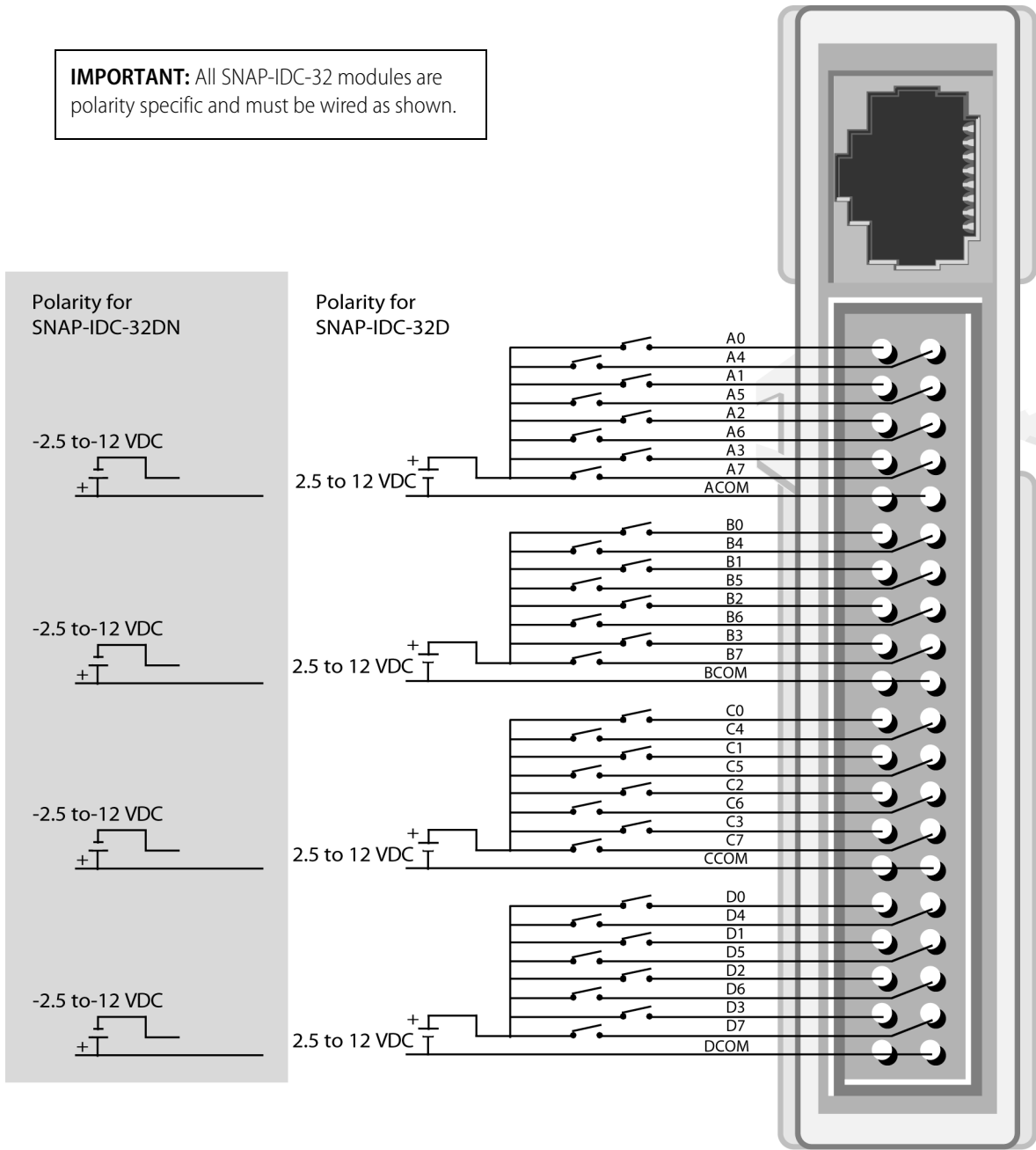

Wiring for SNAP-ODC-32-SNK and SNAP-ODC-32-SRC high-density digital outputs .

Also see wiring for connector on [page 70](#).

FUSING

For both sourcing and sinking modules, either fuse each point (as shown in the first and third groups, below) or fuse each group of points (as shown in the second and fourth groups).

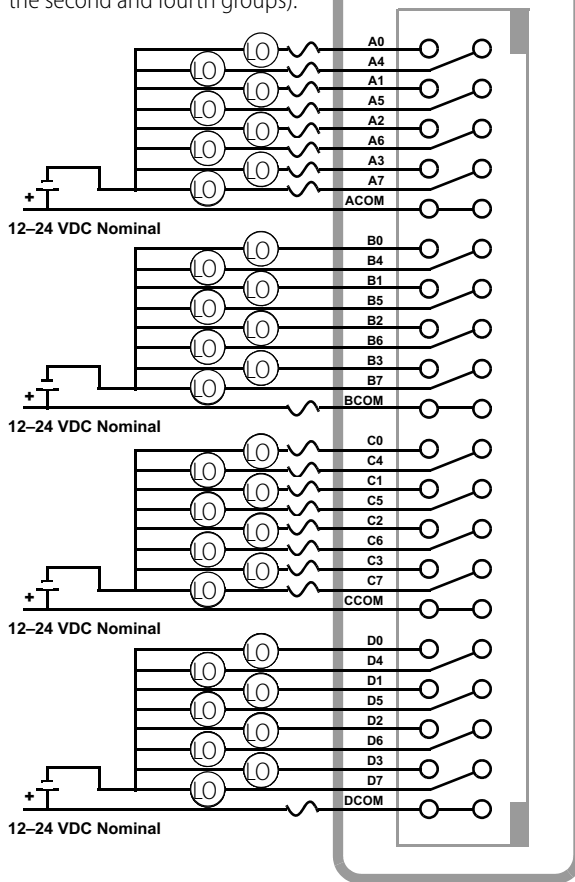

SNAP-ODC-32-SRC
Load Sourcing Module
(Top view of module)

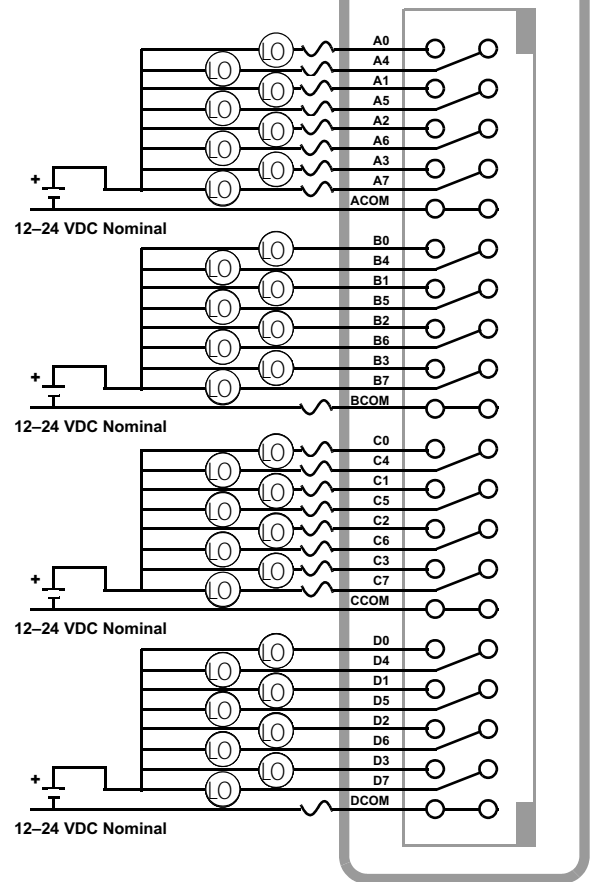

SNAP-ODC-32-SNK
Load Sinking Module
(Top view of module)

Analog Input Modules

Wiring for SNAP-AIARMS analog amps RMS AC/DC input.

Two possible wiring diagrams are shown.

Terminals 3, 4, 7, and 8 share a common connection inside the module. **Make sure you observe polarity** when connecting the second channel. To avoid a potentially hazardous short, double-check wiring before turning on the current to be monitored.

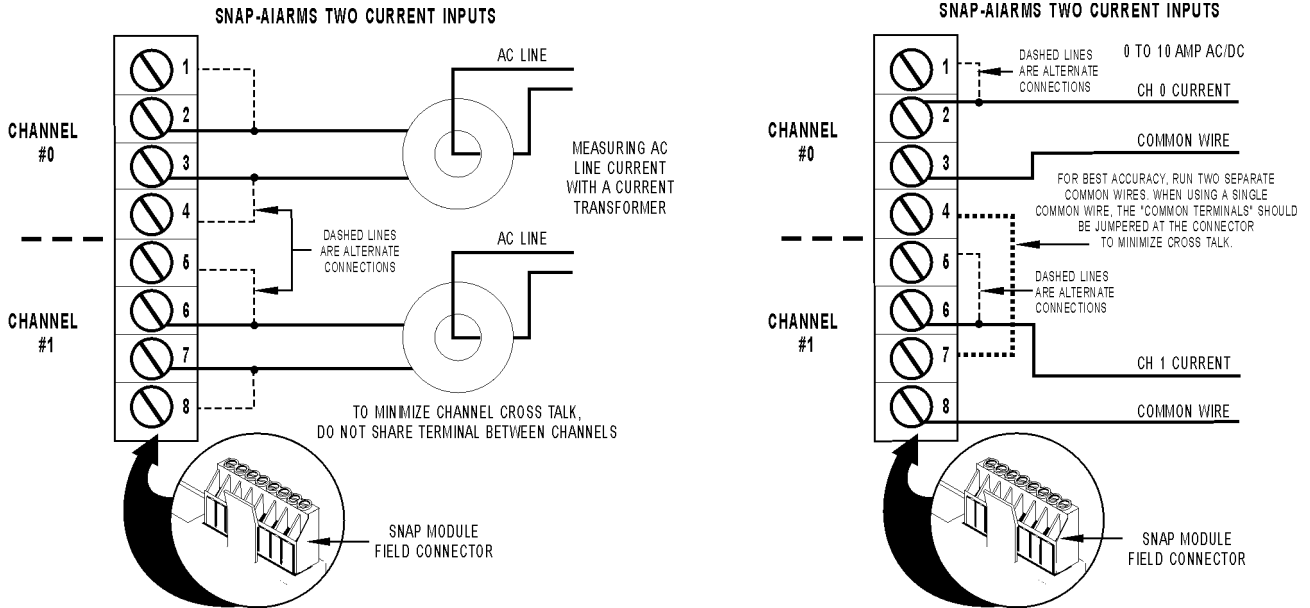

Wiring for SNAP-AIARMS-i isolated analog amps RMS AC/DC inputs.

Two possible wiring diagrams are shown. The module's two points are isolated from each other.

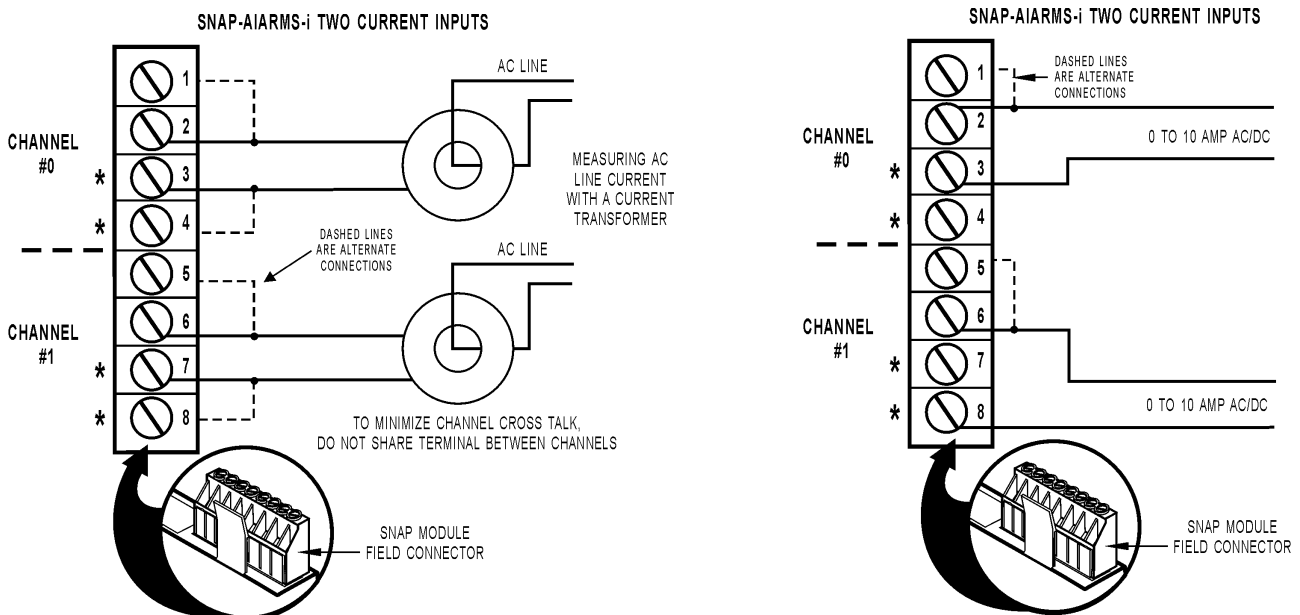

Wiring for SNAP-AIVRMS analog volts RMS AC/DC input.

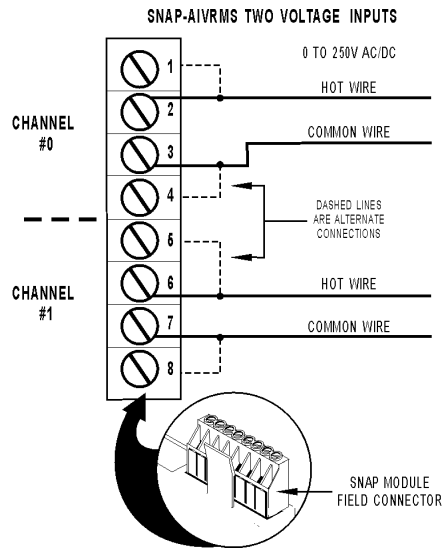

Terminals 3, 4, 7, and 8 share a common connection inside the module. **Make sure you observe polarity** when connecting the second channel. To avoid a potentially hazardous short, double-check wiring before turning on the voltage to be monitored.

Wiring for SNAP-AIVRMS-i isolated analog volts RMS AC/DC input.

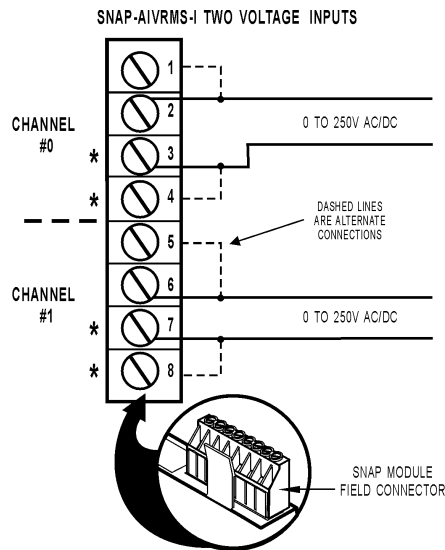

The two points on these modules are isolated from each other.

Wiring for SNAP-AICTD two-channel analog temperature input.

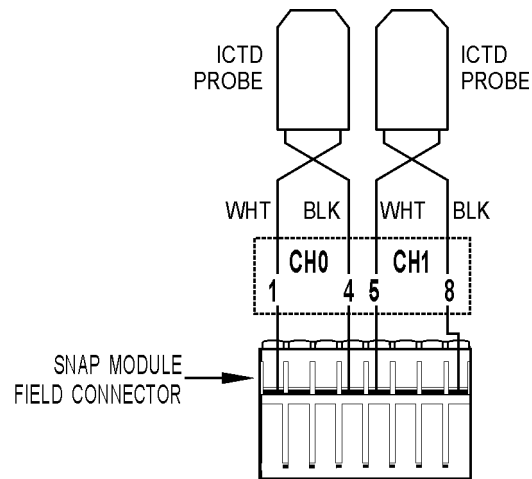

Wiring for SNAP-AICTD-4 four-channel analog temperature input.

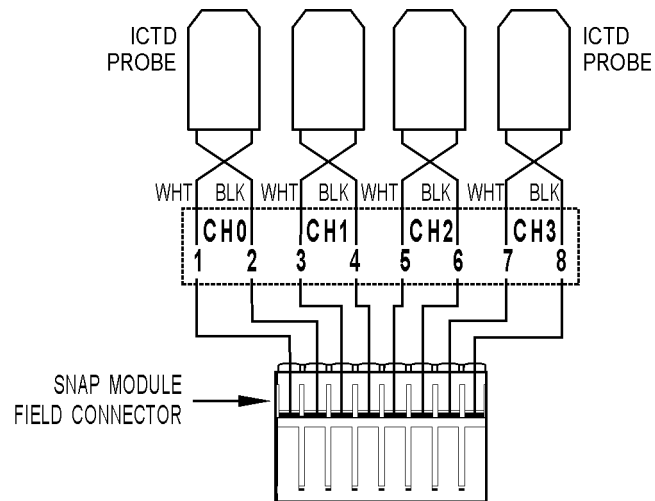

Wiring for SNAP-AICTD-8 eight-channel analog temperature input.

ICTD Source

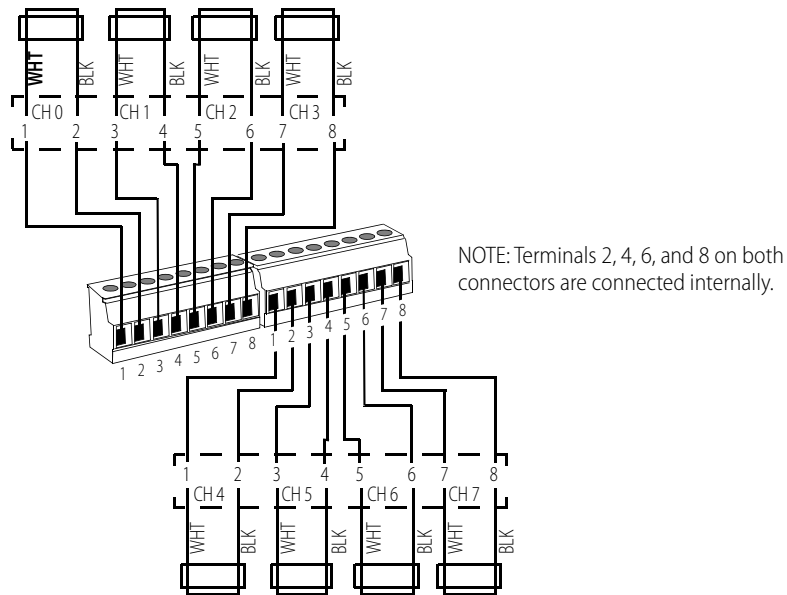

Wiring for SNAP-AILC and SNAP-AILC-2 load cell inputs.

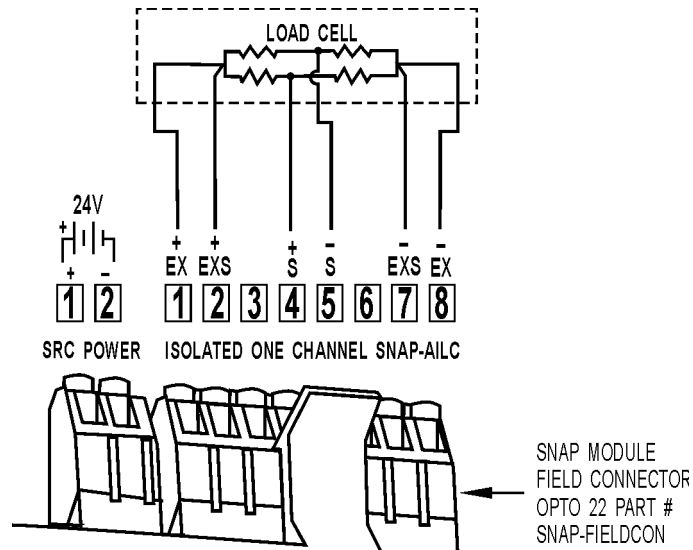

Wiring for SNAP-AIMA two-channel analog current input.

Since all inputs share a common reference, the module must be installed at the beginning or end of a typical 4–20 mA loop. If you are using both standard and self-sourcing transmitters, either put the transmitters on different modules, or use different power supplies. Do not use standard and self-sourcing transmitters on the same module. This module does NOT supply loop excitation current.

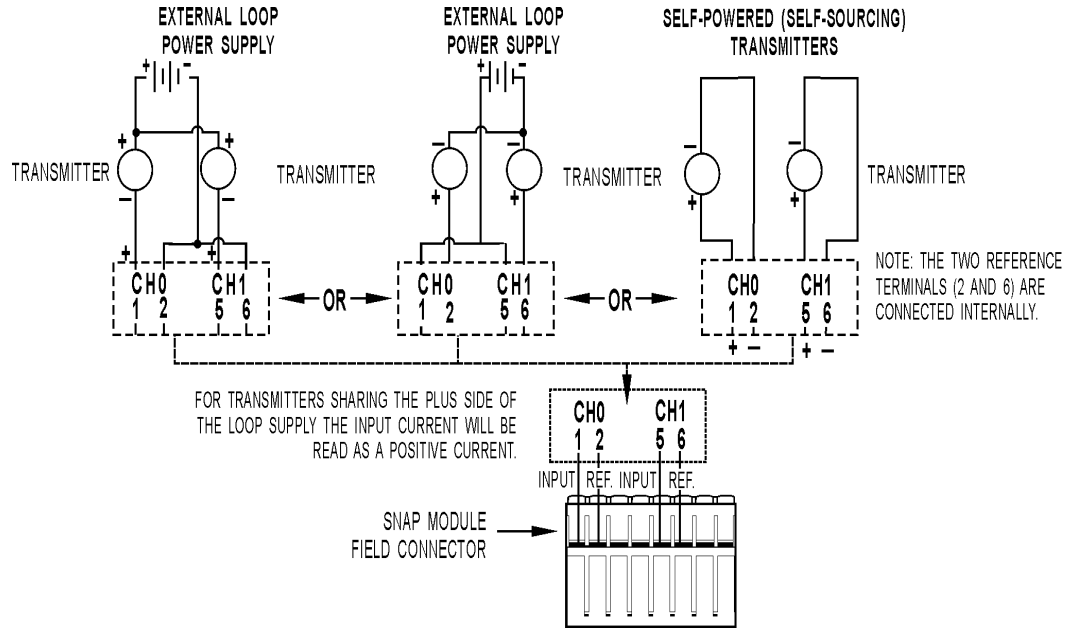

Wiring for SNAP-AIMA-4 four-channel analog current input.

Since all inputs share a common reference, the module must be installed at the beginning or end of a typical 4–20 mA loop. If you are using both standard and self-sourcing transmitters, either put the transmitters on different modules, or use different power supplies. Do not use standard and self-sourcing transmitters on the same module. This module does NOT supply loop excitation current.

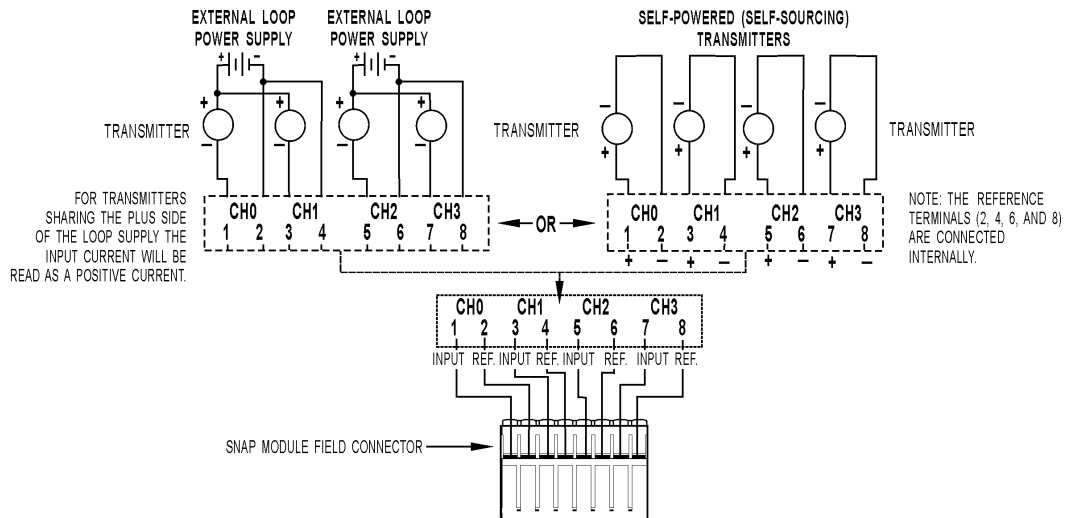

Wiring for SNAP-AIMA-8 eight-channel analog current input.

Since all inputs share a common reference, the module must be installed at the beginning or end of a typical 4–20mA loop. If you are using both standard and self-sourcing transmitters, either put the transmitters on different modules, or use different power supplies. Do not use standard and self-sourcing transmitters on the same module. This module does NOT supply loop excitation current.

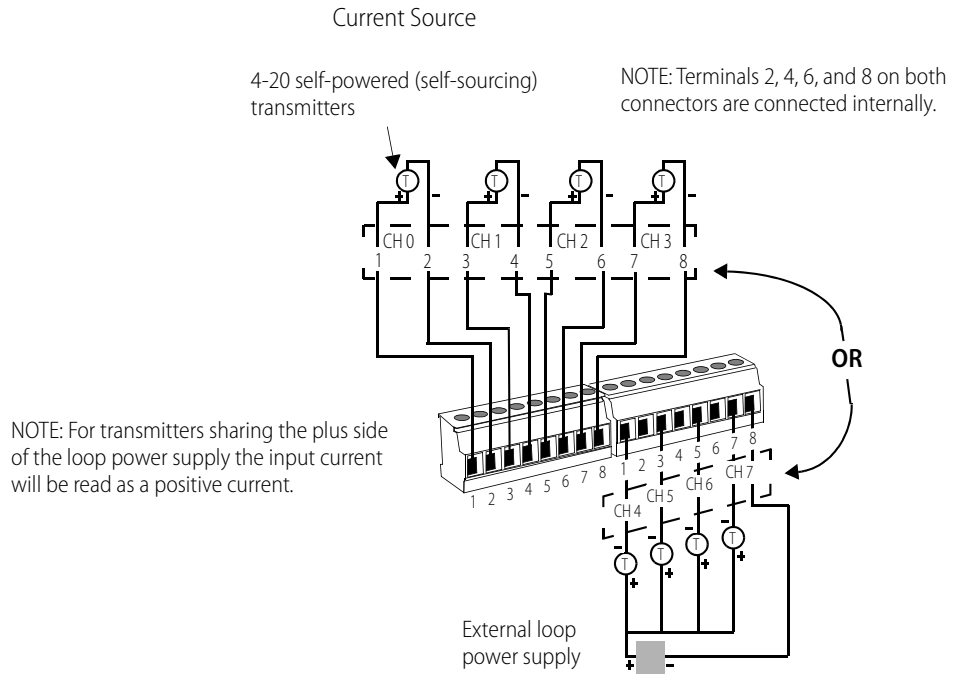

Wiring for SNAP-AIMA-i and SNAP-AIMA2-i isolated two-channel analog current inputs.

The two channels are isolated from each other.
 This module does NOT supply loop excitation current.

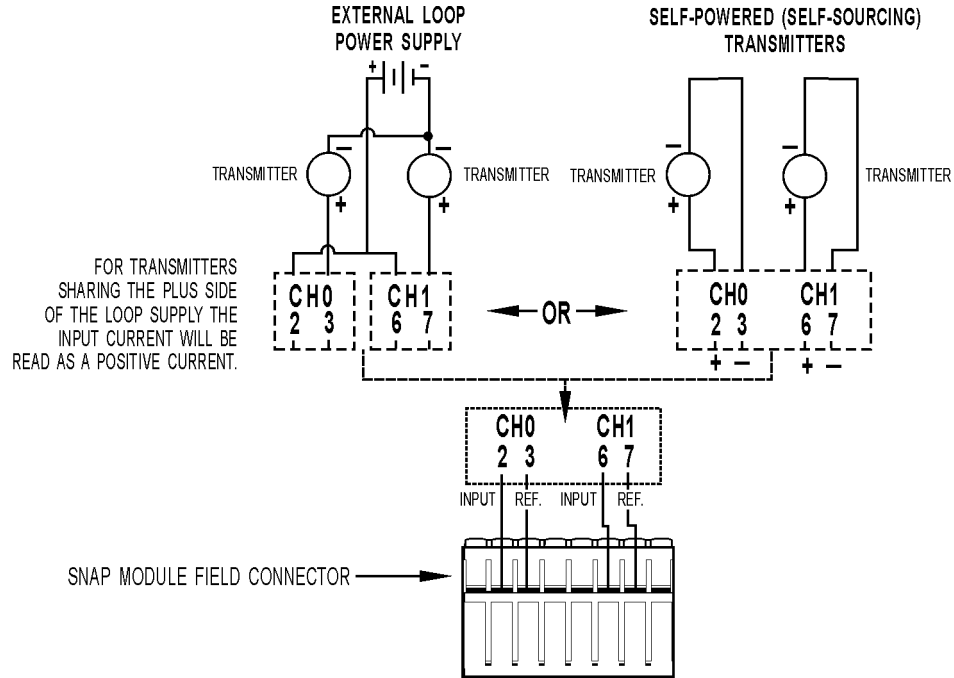

SNAP-AIMA Wiring: Positive Common vs. Negative Common Connections.

The following diagrams apply to SNAP-AIMA-2, SNAP-AIMA-4, and SNAP-AIMA-8 modules.

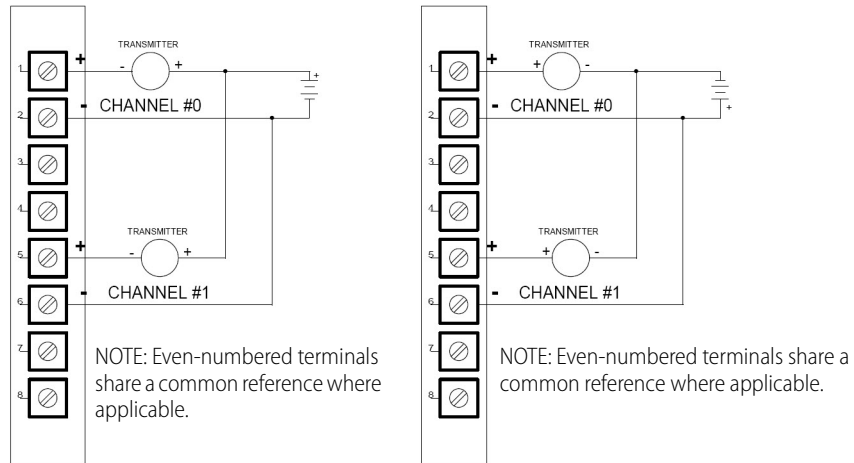

SNAP-AIMA
 For transmitters sharing the plus side of the loop supply.
 Note that input current will be read as a positive current.

SNAP-AIMA
 For transmitters sharing the minus side of the loop supply.
 Note that input current will be read as a negative current.

Wiring for SNAP-AIMA-32 thirty-two-channel analog current input.

This module does NOT supply loop excitation current.

Since all inputs share a common reference, the module must be installed at the beginning or end of a typical 4–20 mA loop. If you are using both standard and self-sourcing transmitters, either put the transmitters on different modules or use different power supplies.

The following diagram shows wiring from the SNAP-AIMA-32 module to the SNAP-AIMA-HDB breakout rack. We strongly recommend that the breakout rack be used with the module. Miswiring of any point on the module can cause severe out-of-warranty damage. The breakout rack protects the module from many wiring errors.

NOTE: if you are using the module with loop power (2-wire) devices, connect to the SNAP-AIMA-HDB rack. If you are using the module with self-powered devices (4-wire) or with devices that share a common positive connection, do not use the SNAP-AIMA-HDB board, which has a current limiting diode. Instead, wire to the SNAP-AIV-HDB (page 89 or page 90).

Use this diagram with loop power (2-wire) negative common devices only. For self-powered (4-wire) devices, see page 89. For positive common devices, see page 90.

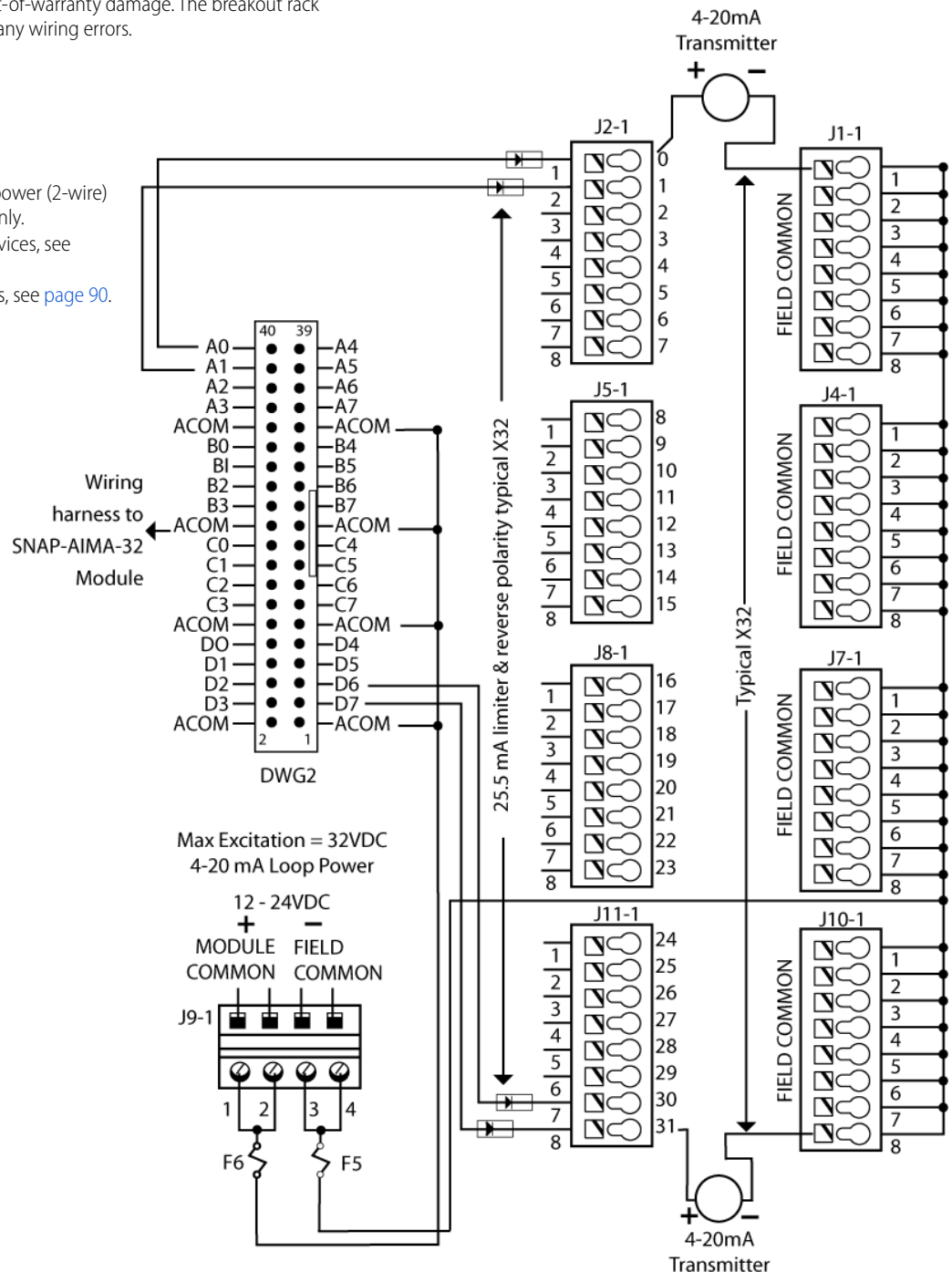

Wiring for SNAP-AIMA-iSRC and SNAP-AIMA-iSRC-FM isolated two-channel analog current inputs.

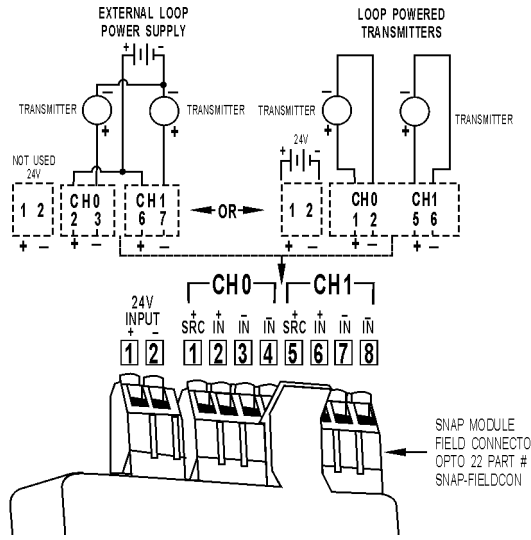

The two channels are isolated from each other. This module DOES supply loop excitation current.

Wiring for SNAP-AIR40K-4 analog thermistor input.

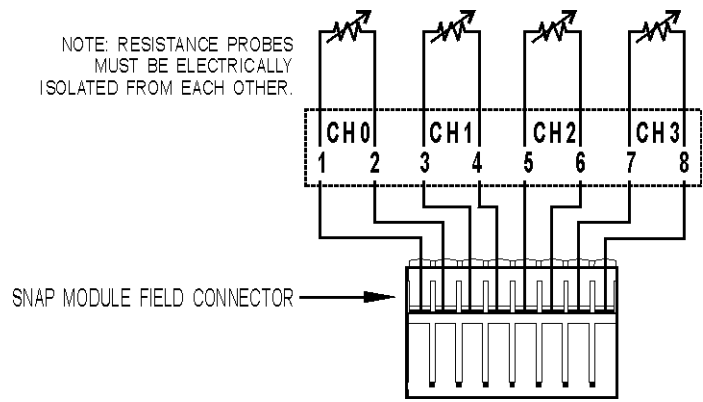

Wiring for SNAP-AIR400K-8 analog thermistor input.

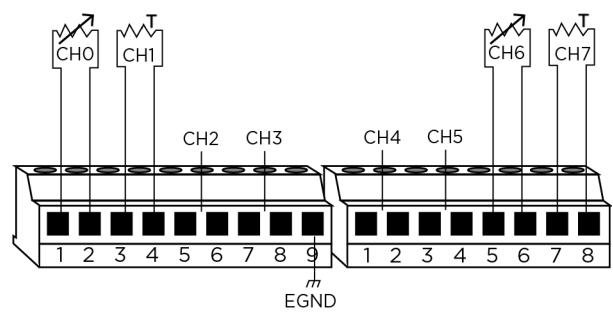

Wiring for SNAP-AIRATE analog rate input.

Two possible wiring diagrams are shown:

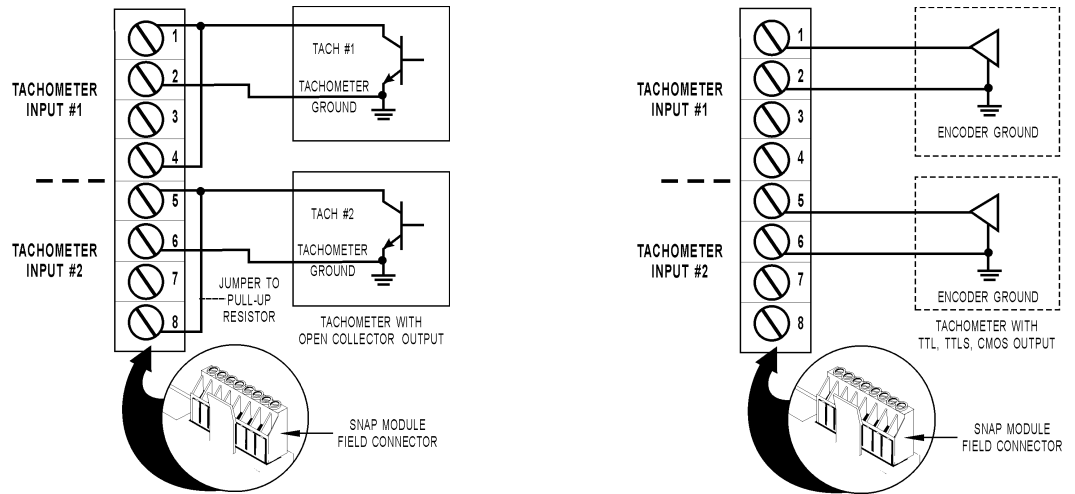

Wiring for SNAP-AIRATE-HFi analog rate input.

Two possible wiring diagrams are shown.

The two channels on the module are isolated from each other. Since these channels do not share any common connections, grounded sensors and field devices may be used with them.

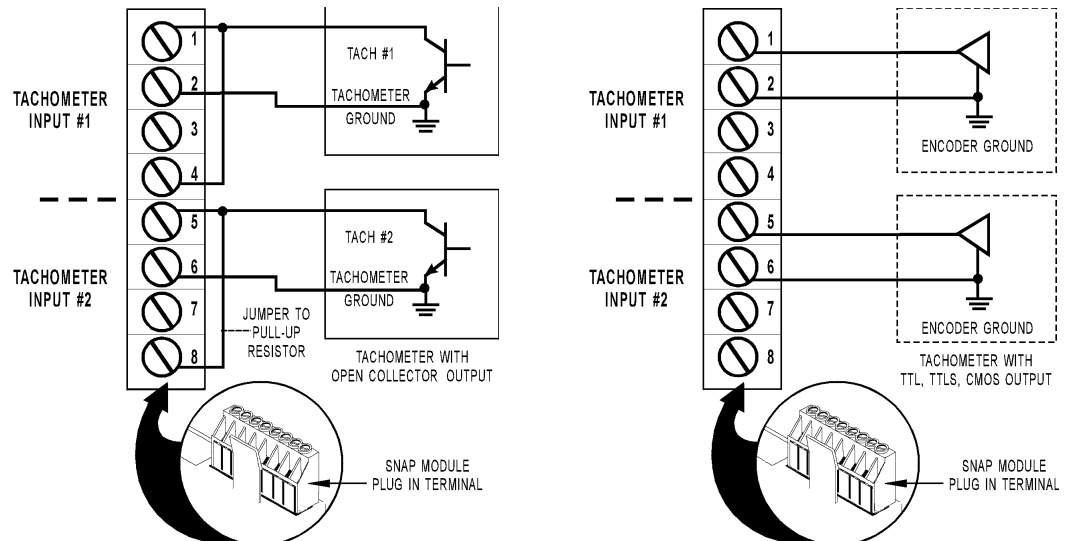

Wiring for SNAP-AIMV-4 and AIMV2-4 analog millivolt inputs.

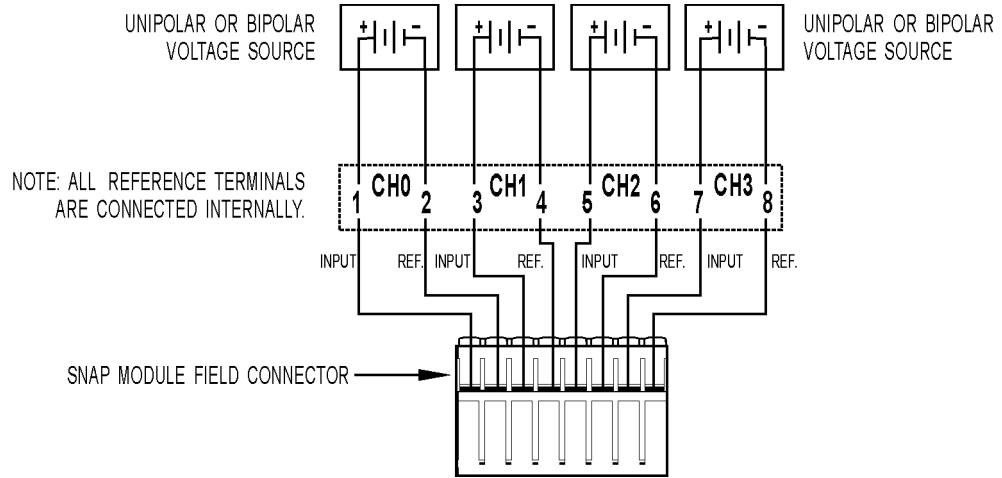

Wiring for SNAP-AITM and SNAP-AITM-2 analog thermocouple/millivolt inputs.

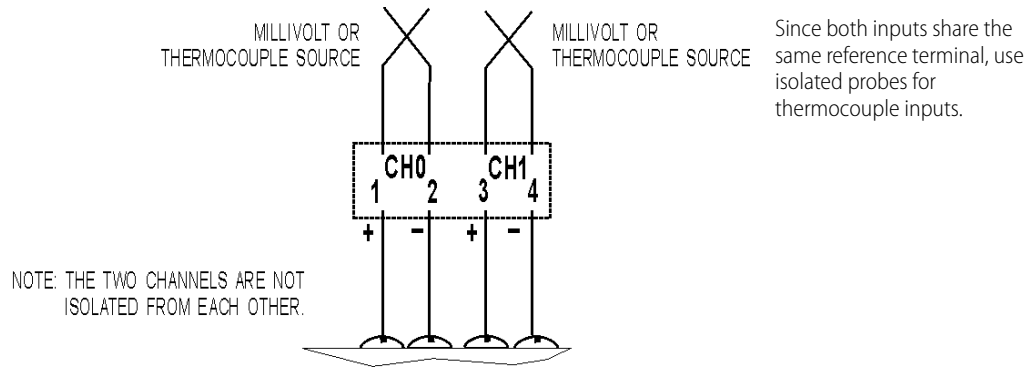

Wiring for SNAP-AITM-8 analog thermocouple/millivolt input.

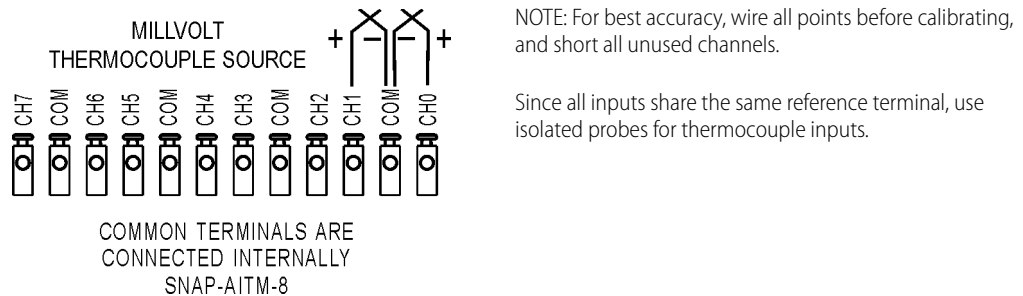

Wiring for SNAP-AITM-i and SNAP-AITM2-i isolated analog thermocouple/millivolt inputs.

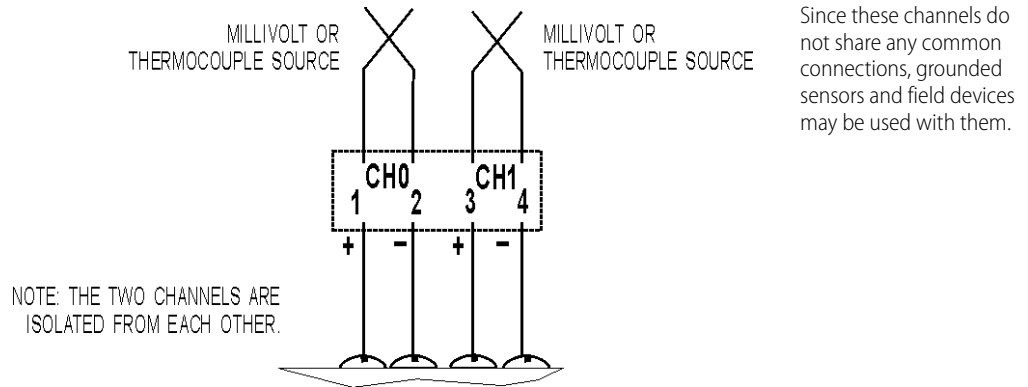

Since these channels do not share any common connections, grounded sensors and field devices may be used with them.

Wiring for SNAP-AITM-4i isolated analog thermocouple/millivolt input. .

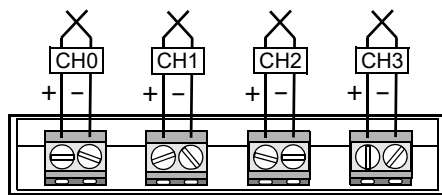

The four channels on the module are isolated from each other. Since these channels do not share any common connections, grounded sensors and field devices may be used with them.



Wiring for SNAP-AIRTD, SNAP-AIRTD-10, and SNAP-AIRTD-1K analog RTD inputs.

SNAP-AIRTD modules are designed for three-wire connections, shown in the diagram at right.

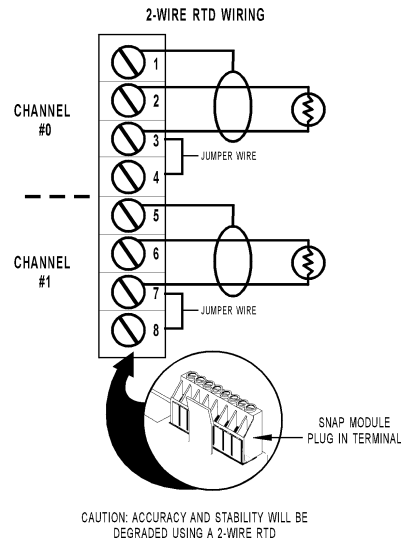
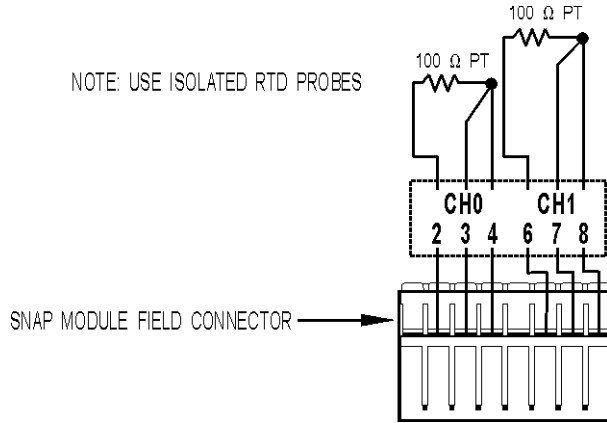

Wiring for SNAP-AIRTD-8U analog RTD/resistance inputs.

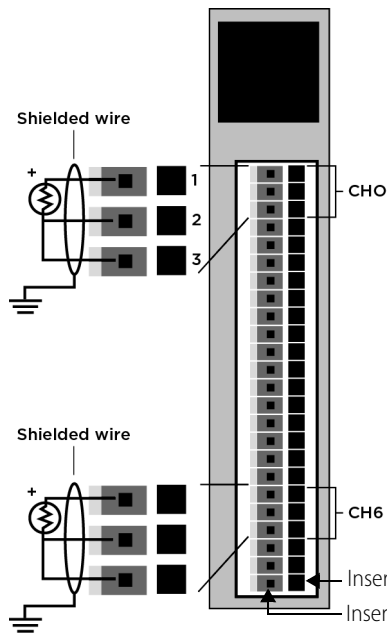

The SNAP-AIRTD-8U has spring-clamp connectors for easy wiring. An insertion tool is provided in the box with the module. For each connection:

1. Insert the tool in the small square hole and push down.
2. Push the wire firmly into the rectangular hole below the tool, and then remove the tool.

The module is designed for 3-wire RTDs, shown below. All wires must be the same size. If you use a 4-wire connection, DO NOT connect the fourth wire, as it will cause errors in the readings. If you use 2-wire RTDs (not recommended because measurement is less accurate), you must jumper terminal 2 to 3 for each applicable RTD channel.

Wiring for SNAP-AIV two-channel analog voltage input.

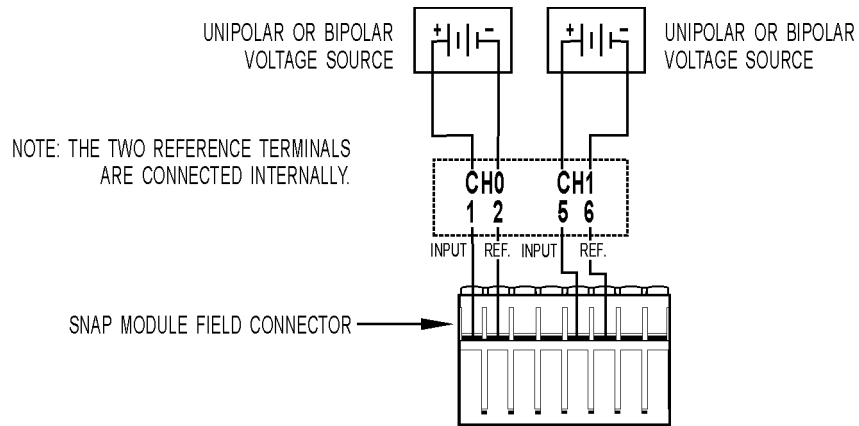

Wiring for SNAP-AIV-4 four-channel analog voltage input.

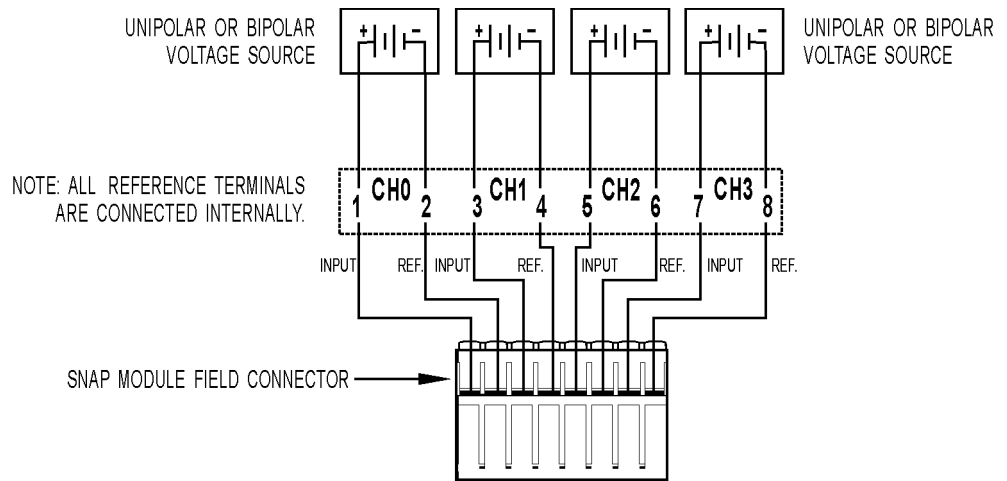

Wiring for SNAP-AIV-8 eight-channel analog voltage input.

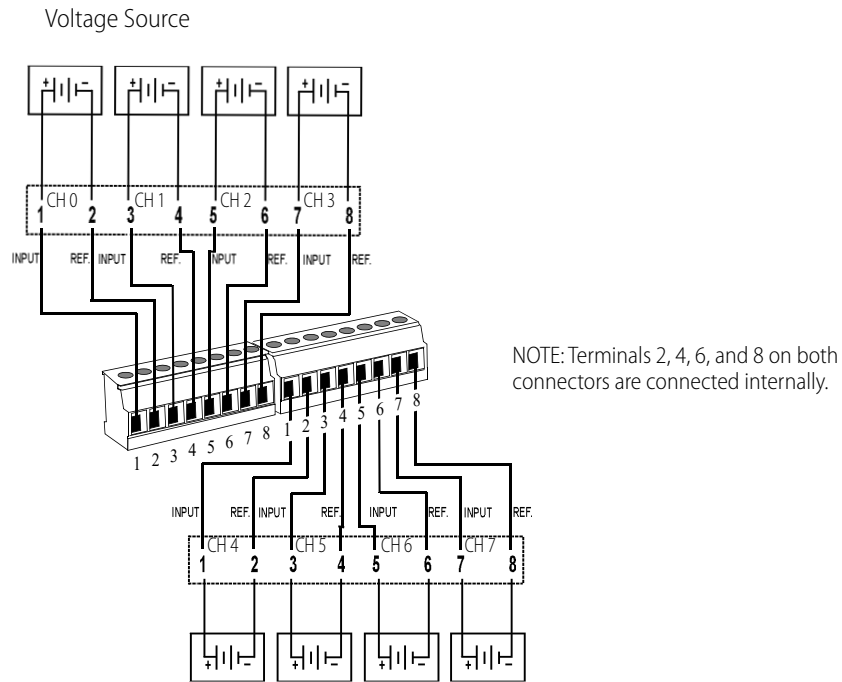

Wiring for SNAP-AIV-i and SNAP-AIV2-i isolated two-channel analog voltage input.

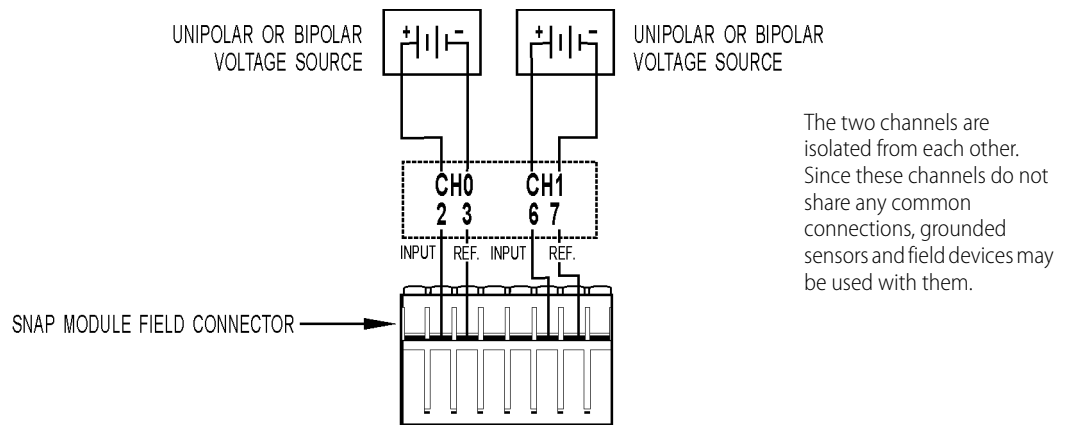

Wiring for SNAP-AIV-32 thirty-two-channel analog voltage input.

The following diagram shows wiring from the SNAP-AIV-32 module to the SNAP-HDB-AIV breakout rack. Note that all channels share a common reference terminal.

NOTE: This diagram is also used to wire the SNAP-AIV-HDB breakout rack to a SNAP-AIMA-32 module, when the module connects to a self-powered (4-wire) device.

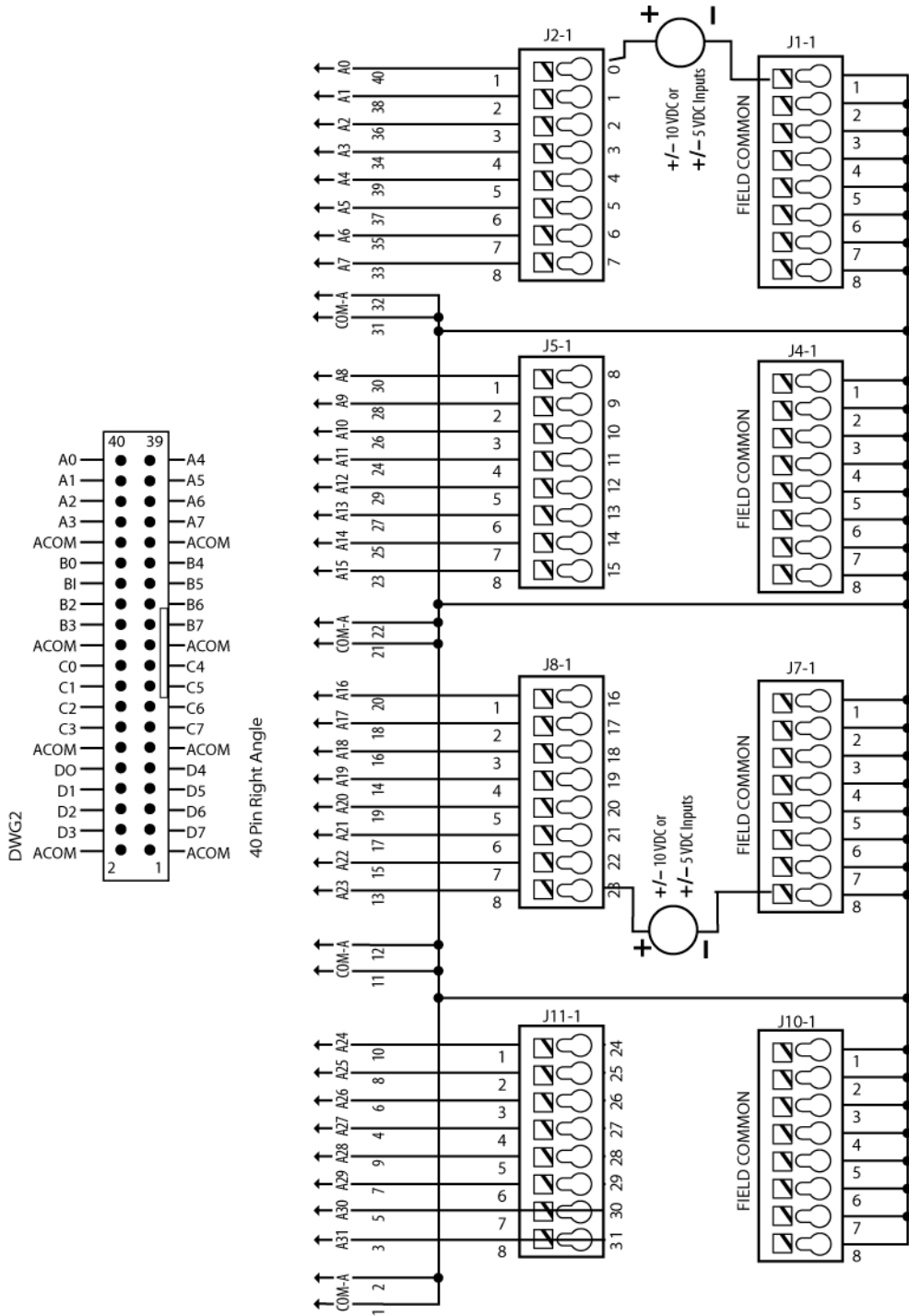

Alternate Wiring for SNAP-AIMA-32 .

SNAP-AIV-HDB breakout rack to SNAP-AIMA-32 module when the module connects to devices that share a positive common connection

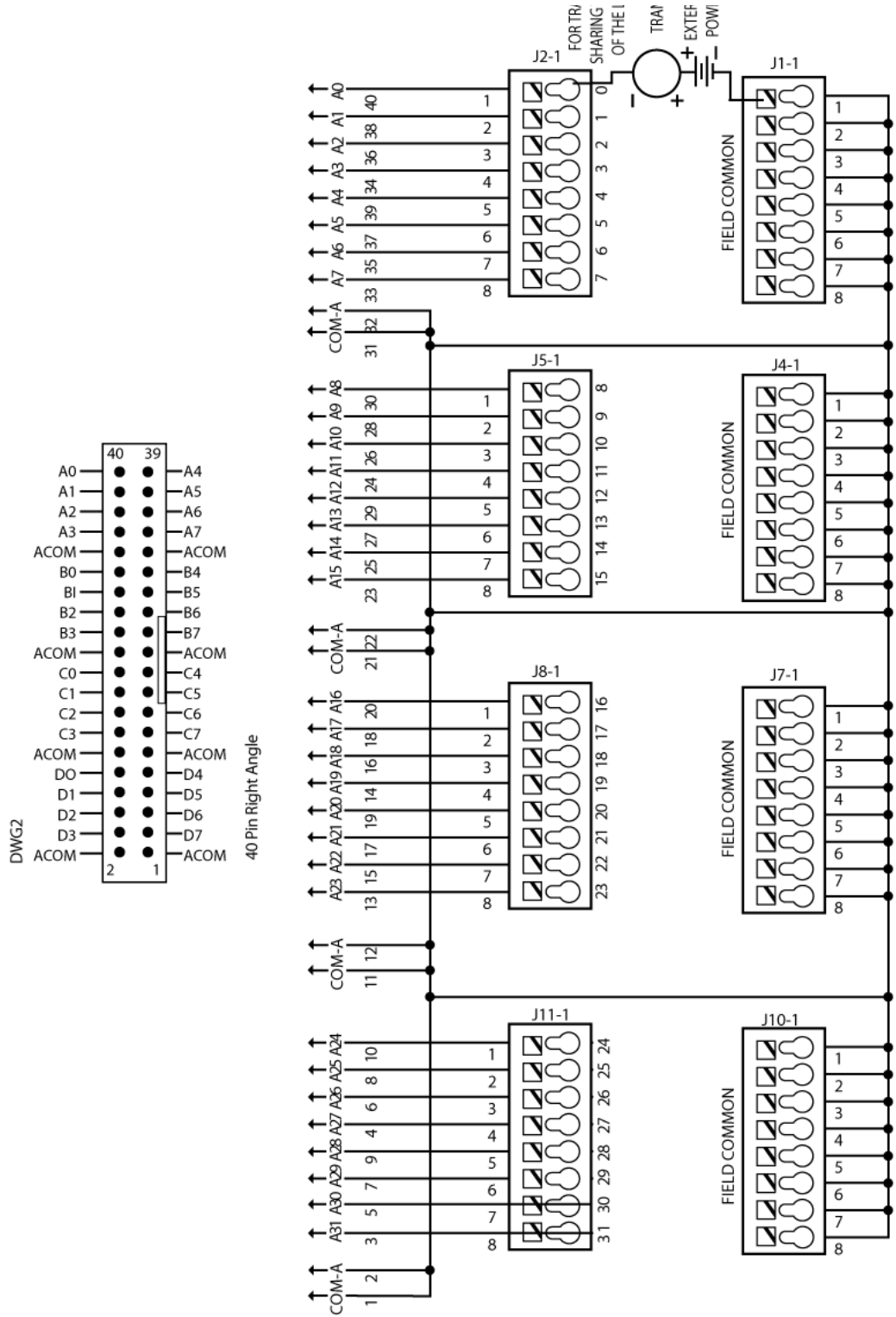

Analog Output Modules

Wiring for the SNAP-AOA-3 single-channel analog current output.

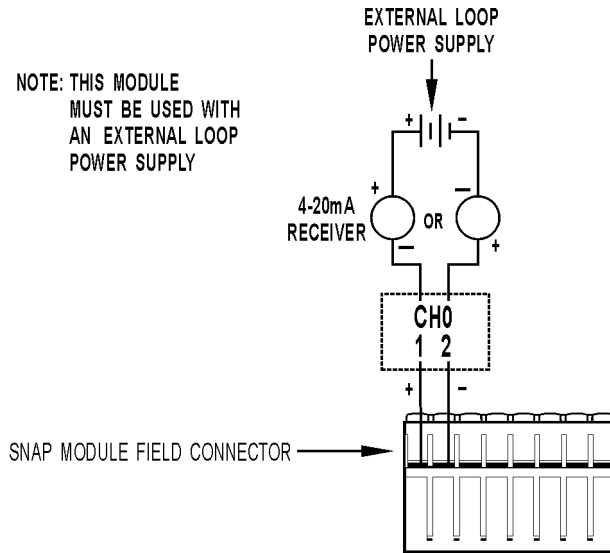

Wiring for the SNAP-AOV-5 single-channel analog voltage outputs.

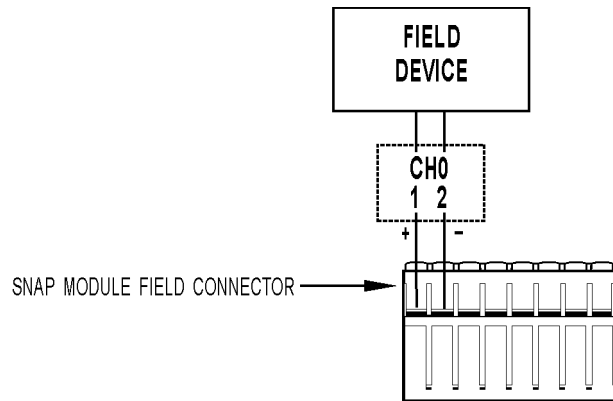

Wiring for the SNAP-AOA-23 dual-channel analog current output.

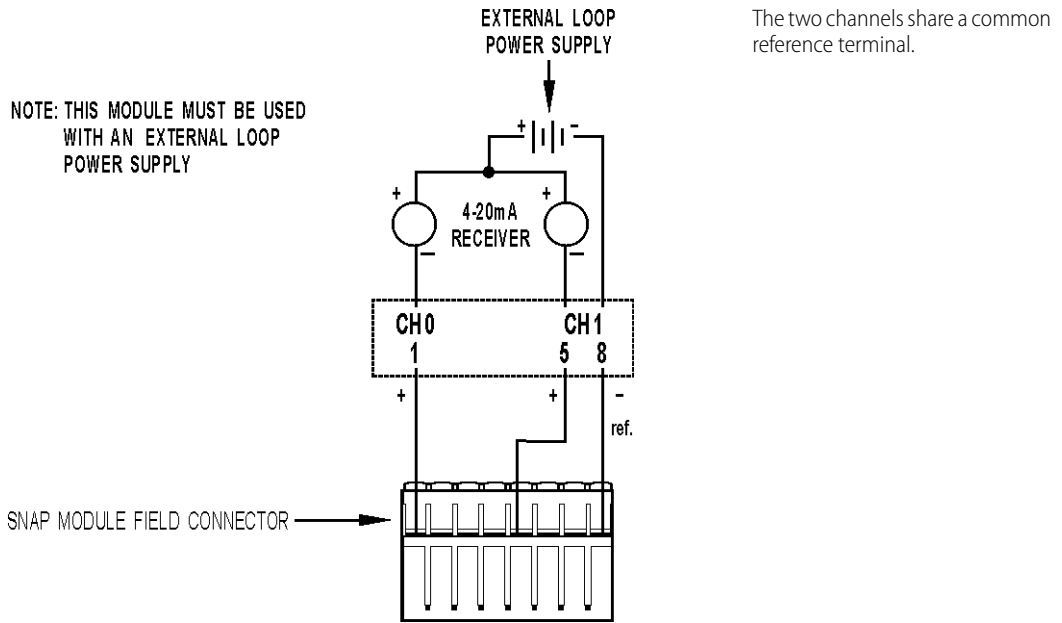

Wiring for the SNAP-AOA-23-iSRC and SNAP-AOA-23-iSRC-FM isolated dual-channel analog current outputs.

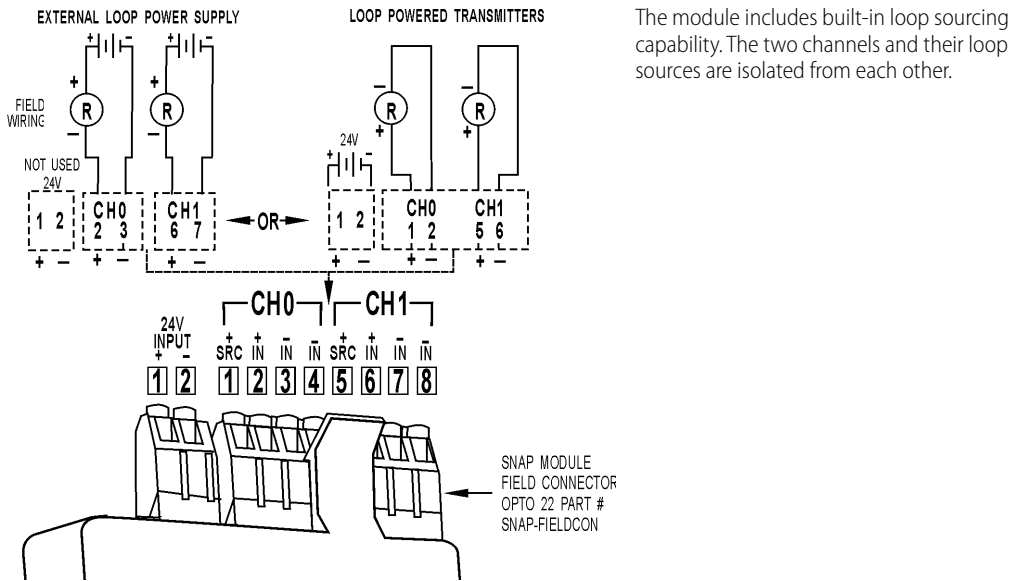

Wiring for the SNAP-AOV-25 and SNAP-AOV-27 dual-channel analog voltage output.

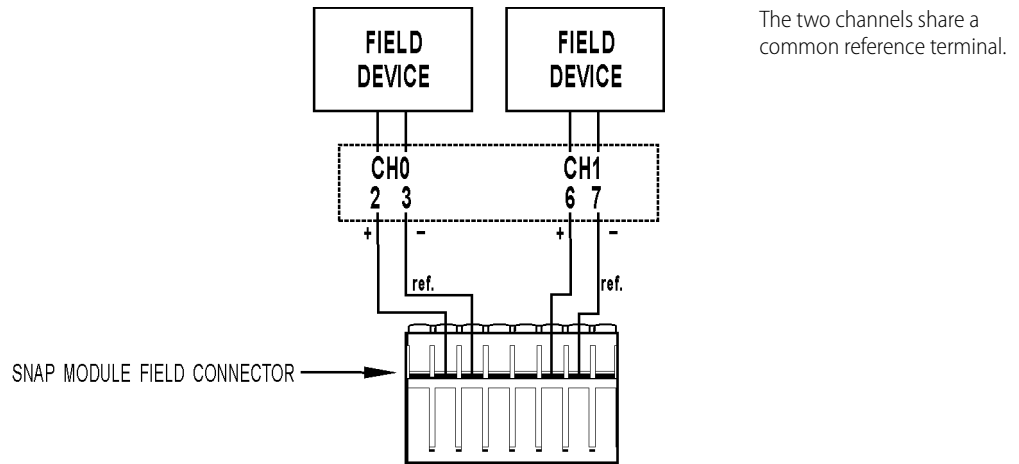

Wiring for the SNAP-AOA-28 dual-channel analog current output.

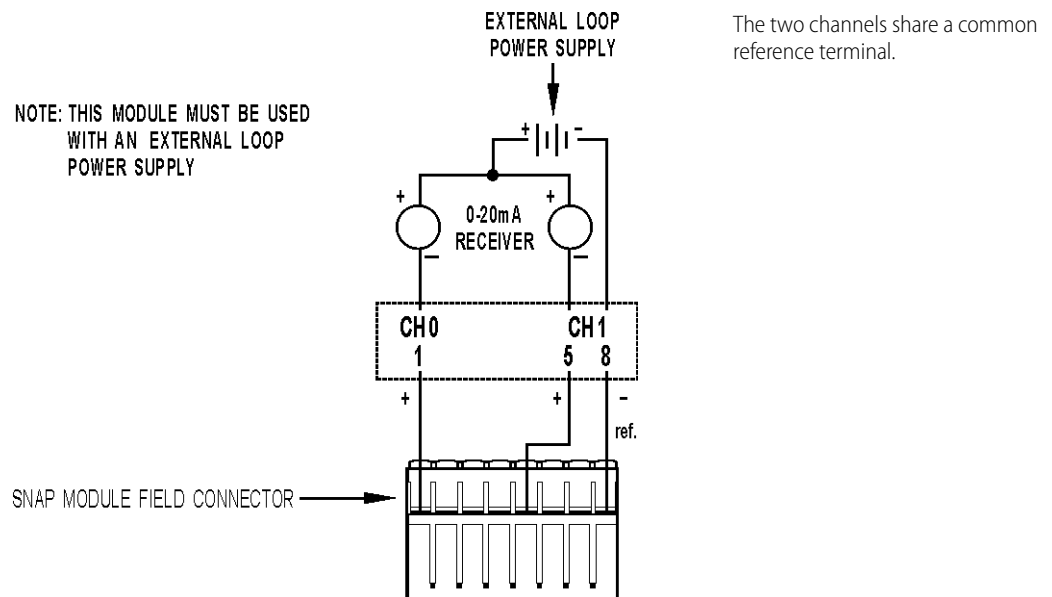

Wiring for the SNAP-AOVA-8 eight-channel analog multifunction output.

This module requires a SNAP-HD-20F6 cable.

SNAP-AOVA-8 Module (from top)

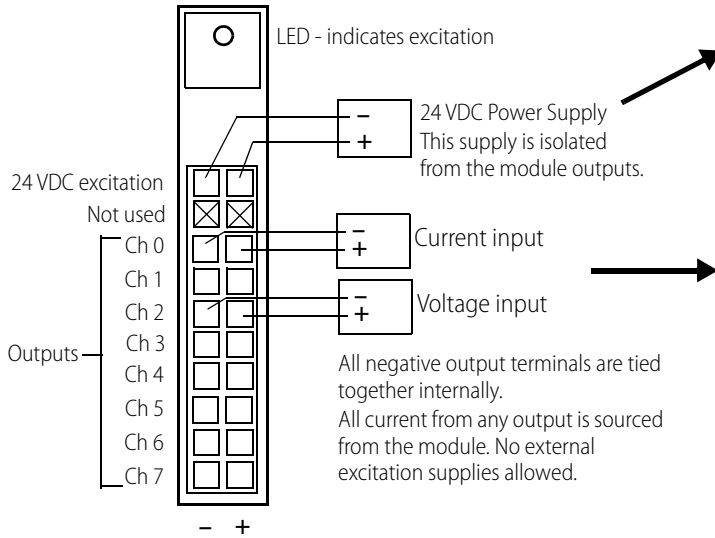

SNAP-HD-20F6 Cable

Wire colors - Excitation

24 VDC	Color
-	Black
+	White with Black

Wire colors - Output points

Ch	-/+	Color
0	-	Blue
	+	White with Blue
1	-	Pink
	+	White with Pink
2	-	Gray
	+	White with Gray
3	-	Green
	+	White with Green
4	-	Orange
	+	White with Orange
5	-	Red
	+	White with Red
6	-	Purple
	+	White with Purple
7	-	Yellow
	+	White with Yellow



For more information on the SNAP-HD-20F6 cable, see form 1756, the *SNAP TEX Cables & Breakout Boards Data Sheet*.

NOTE: Yellow with purple and purple with yellow wires are not used.

Wiring for the SNAP-AOD-29 dual-channel analog time-proportional digital output.

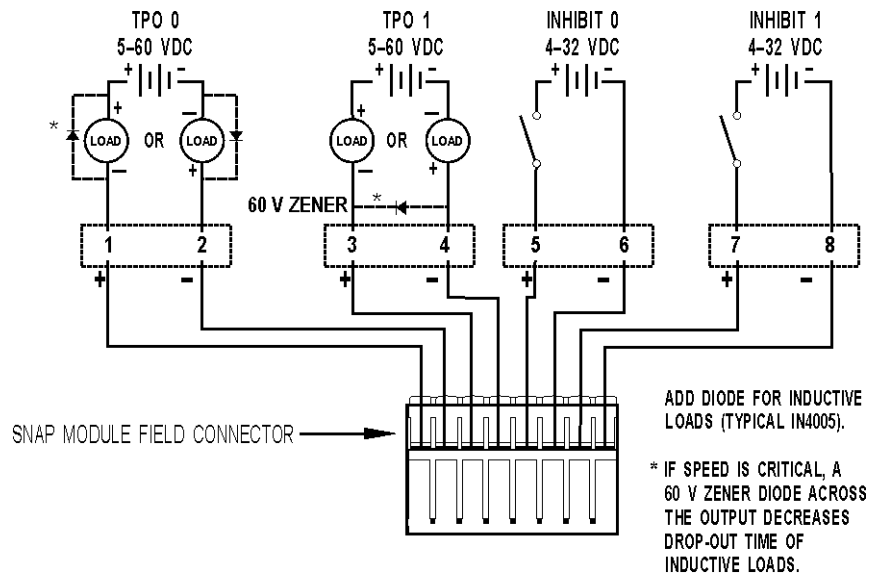

Wiring for the SNAP-AOD-29-HFi dual-channel analog time-proportional digital output.

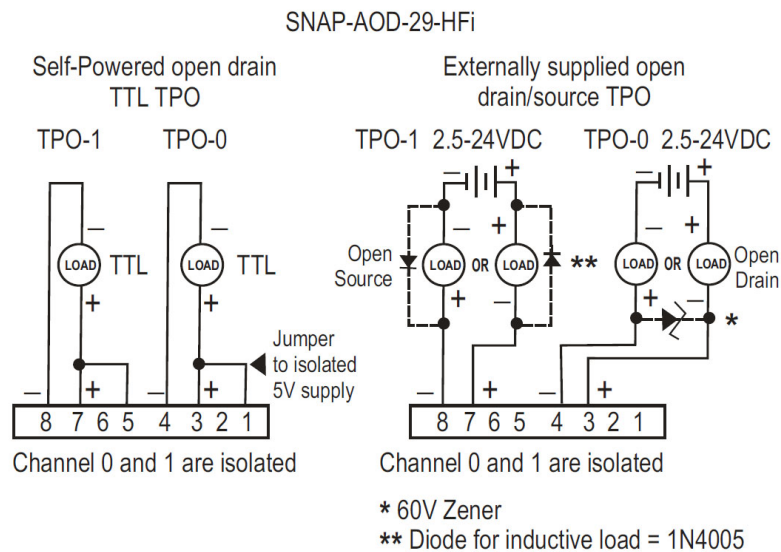

WARNING: Do not remove or replace connectors or cards while circuit is live unless area is known to be nonhazardous.

Serial Communication Modules

Wiring for the SNAP-SCM-232 serial communication module.

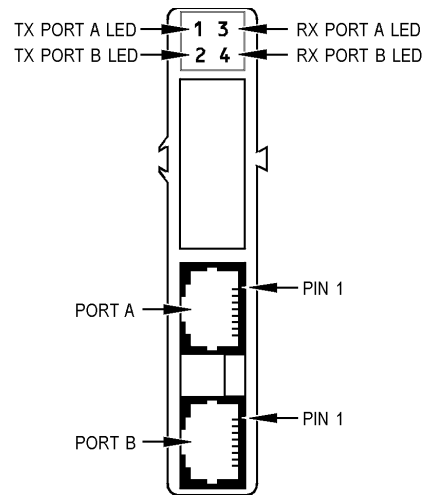

Pinouts for RJ-45 connectors on the SNAP-SCM-232:

1	Not used
2	RX (receive data)
3	TX (transmit data)
4	RTS (request to send)
5	GND (signal ground)
6	Not used
7	Not used
8	CTS (clear to send)

Refer to Opto 22 form #1191, the *SNAP Serial Communication Module User's Guide*, for more information.

Wiring for the SNAP-SCM-485-422 serial communication module.

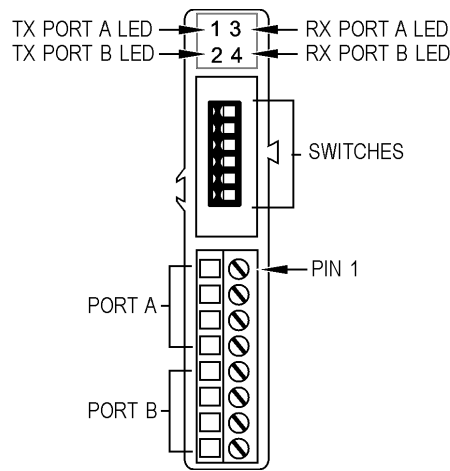

Pinouts for Two-Wire SNAP-SCM-485			Pinouts for Four-Wire SNAP-SCM-485		
Pin	Port	Description	Pin	Port	Description
1	A	Vcc	1	A	Vcc
2	A	TX/RX +	2	A	TX +
3	A	TX/RX -	3	A	TX -
4	A	Sig Gnd	4	A	Sig Gnd
5	B	Vcc	5	A	Vcc
6	B	TX/RX +	6	A	RX +
7	B	TX/RX -	7	A	RX -
8	B	Sig Gnd	8	A	Sig Gnd

NOTE: Vcc on the SNAP-SCM-485 is 5 VDC and is supplied by the module itself. Do not use this voltage to power another device, as it can interfere with normal module operation.

Use the small switches on the top of the module to provide bias or termination on the RS-485 network as required. If the port is physically the first or last device on the RS-485 network, provide termination by moving the Term switch to ON. Also provide bias at one point on the network by moving both the Up and Down switches to ON.

Bias and termination switches are shown in the diagram at right.

Refer to Opto 22 form #1191, the *SNAP Serial Communication Module User's Guide*, for more information.

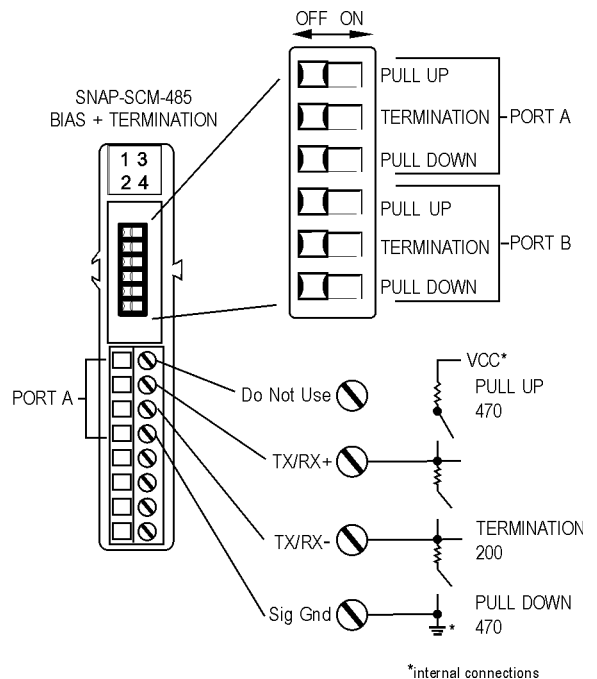

NOTE: Vcc on the SNAP-SCM-485 is 5 VDC and is supplied by the module itself. Do not use this voltage to power another device, as it can interfere with normal module operation.

Wiring for the SNAP-SCM-ST2 serial communication module.

NOTE: Use with SNAP PAC R-series controllers and SNAP PAC EB brains only.

SNAP-SCM-ST2 Top View.

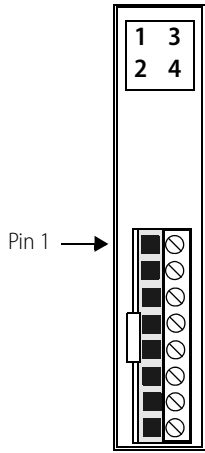

Pinouts

Pin	Channel	Use	Description
1	A	Pulse	Frequency output.
2		Ground	Isolated from logic side
3		Direction	+5 VDC when asserted, 0 VDC when deasserted.
4		Ground	Isolated from logic side
5	B	Pulse	Frequency output.
6		Ground	Isolated from logic side
7		Direction	+5 VDC when asserted, 0 VDC when deasserted.
8		Ground	Isolated from logic side

Wiring for the SNAP-SCM-CAN2B serial communication module.

NOTE: Use with SNAP PAC R-series controllers and SNAP PAC EB brains only.

SNAP-SCM-CAN2B Top View.

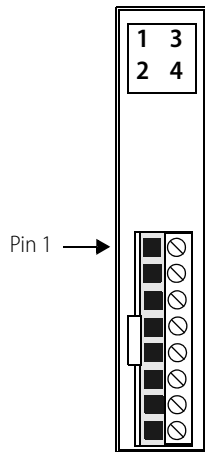

Pinouts for SNAP-SCM-CAN2B

Pins 1-4 are in parallel to pins 5-8.
V+ is not used by the module.

Pin	Use
1,5	V +
2,6	CAN +
3,7	CAN -
4,8	GND

A: I/O Specifications

INTRODUCTION

This appendix includes specifications for the following SNAP PAC System I/O modules:

Digital input modules	page 100
Digital output modules	page 105
Analog input modules	page 116
Analog output modules	page 136
Serial modules	page 143
Breakout boards and cables	page 145

DIGITAL INPUT MODULE SPECIFICATIONS

SNAP-IAC5, SNAP-IAC5A, and SNAP-IAC5MA

	SNAP-IAC5	SNAP-IAC5A	SNAP-IAC5MA
Key Feature	--	--	Diagnostic switches
Wire size	22 to 14 AWG	22 to 14 AWG	22 to 14 AWG
Torque, hold-down screws	Not to exceed 1 in-lb (0.11 N-m)	Not to exceed 1 in-lb (0.11 N-m)	Not to exceed 1 in-lb (0.11 N-m)
Torque, connector screws	5.22 in-lb (0.59 N-m)	5.22 in-lb (0.59 N-m)	5.22 in-lb (0.59 N-m)
Field Side Ratings (each channel)			
Nominal Input Voltage	120 VAC/VDC	240 VAC/VDC	120 VAC/VDC
Channel-to-channel isolation	300 VAC (1,500 V transient)	300 VAC (1,500 V transient)	300 VAC (1,500 V transient)
Input Voltage Range	90–140 VAC/VDC	180–280 VAC/VDC	90–140 VAC/VDC
Turn-on Voltage	90 VAC/VDC	180 VAC/VDC	90 VAC/VDC
Turn-off Voltage	35 VAC/VDC	35 VAC/VDC	35 VAC/VDC
Input Resistance	169 K ohms (nominal)	305 K ohms (nominal)	169 K ohms (nominal)
Logic Side Ratings			
Logic Output Voltage	<.5 V max. (on) @ 2 mA sinking 2.7 V min. (off) @ 400 mA sourcing	<.5 V max. (on) @ 2 mA sinking 2.7 V min. (off) @ 400 mA sourcing	<.5 V max. (on) @ 2 mA sinking 2.7 V min. (off) @ 400 mA sourcing
Logic Supply Voltage*	5 VDC ± 0.25 VDC	5 VDC ± 0.25 VDC	5 VDC ± 0.25 VDC
Logic Supply Current	50 mA maximum	50 mA maximum	50 mA maximum
Negative True Logic Output Drive	TTL 74 Series = 1 UL TTL 74LS Series = 5 UL	TTL 74 Series = 1 UL TTL 74LS Series = 5 UL	TTL 74 Series = 1 UL TTL 74LS Series = 5 UL
Module Ratings			
Number of Channels Per Module	4	4	4
Turn-on Time	30 msec	30 msec	30 msec
Turn-off Time	30 msec	30 msec	30 msec
Optical Isolation, Field to Logic	4,000 volts (transient)	4,000 volts (transient)	4,000 volts (transient)
Temperature	-20 °C to 70 °C, operating -40 °C to 85 °C, storage	-20 °C to 70 °C, operating -40 °C to 85 °C, storage	-20 °C to 70 °C, operating -40 °C to 85 °C, storage
Agency Approvals	UL, CE, CSA, RoHS, DFARS; UKCA	UL, CE, CSA, RoHS, DFARS; UKCA	UL, CE, RoHS, DFARS
Warranty	Lifetime	Lifetime	30 months

* When used with an I/O processor (brain or on-the-rack controller), the processor requires 5.0 to 5.2 VDC.

SNAP-IDC5FM

	SNAP-IAC5FM (Obsolete)	SNAP-IAC5AFM (Obsolete)	SNAP-IDC5FM	SNAP-IDC5DFM (Obsolete)
Key Feature	Factory Mutual approved	Factory Mutual approved	Factory Mutual approved	Factory Mutual approved
Wire size	22 to 14 AWG	22 to 14 AWG	22 to 14 AWG	22 to 14 AWG
Torque, hold-down screws	Not to exceed 1 in-lb (0.11 N-m)	Not to exceed 1 in-lb (0.11 N-m)	Not to exceed 1 in-lb (0.11 N-m)	Not to exceed 1 in-lb (0.11 N-m)
Torque, connector screws	5.22 in-lb (0.59 N-m)	5.22 in-lb (0.59 N-m)	5.22 in-lb (0.59 N-m)	5.22 in-lb (0.59 N-m)
Field Side Ratings (each channel)				
Nominal Input Voltage	120 VAC/VDC	240 VAC/ VDC	24 VAC/VDC	5 VDC
Channel-to-channel isolation	300 VAC (1,500 V transient)	300 VAC (1,500 V transient)	300 VAC (1,500 V transient)	300 VAC (1,500 V transient)
Input Voltage Range	90–140 VAC/VDC	180–280 VAC/VDC	10–32 VAC/VDC	2.5–28 VDC
Turn-on Voltage	90 VAC/VDC	180 VAC/VDC	10 VAC/VDC	2.5 VDC
Turn-off Voltage	35 VAC/VDC	35 VAC/VDC	3 VAC/VDC	1 VDC
Input Resistance	169 K ohms (nominal)	305 K ohms (nominal)	15 K ohms (nominal)	3 K ohms (nominal)
Logic Side Ratings				
Logic Output Voltage	<.5 V max. (on) @ 2 mA sinking 2.7 V min. (off) @ 400 mA sourcing	<.5 V max. (on) @ 2 mA sinking 2.7 V min. (off) @ 400 mA sourcing	<.5 V max. (on) @ 2 mA sinking 2.7 V min. (off) @ 0.4 mA sourcing	<.5 V max. (on) @ 2 mA sinking 2.7 V min. (off) @ 0.4 mA sourcing
Logic Supply Voltage*	5 VDC ± 0.25 VDC	5 VDC ± 0.25 VDC	5 VDC ± 0.25 VDC	5 VDC ± 0.25 VDC
Logic Supply Current	50 mA maximum	50 mA maximum	50 mA maximum	50 mA maximum
Negative True Logic Output Drive	TTL 74 Series=1 UL TTL 74LS Series=5 UL	TTL 74 Series=1 UL TTL 74LS Series=5 UL	TTL 74 Series=1 UL TTL 74LS Series=5 UL	TTL 74 Series=1 UL TTL 74LS Series=5 UL
Module Ratings				
Number of Channels Per Module	4	4	4	4
Turn-on Time	30 msec	30 msec	5 msec	1 msec
Turn-off Time	30 msec	30 msec	15 msec	1 msec
Optical Isolation (Field Side to Logic Side)	4,000 volts (transient)	4,000 volts (transient)	4,000 volts (transient)	4,000 volts (transient)
Temperature	-20 to 70 °C, operating -40 to 85 °C, storage	-20 to 70 °C, operating -40 to 85 °C, storage	-20 to 70 °C, operating -40 to 85 °C, storage	-20 to 70 °C, operating -40 to 85 °C, storage
Agency Approvals	CE, FM, RoHS, DFARS; UKCA	CE, FM, RoHS, DFARS; UKCA	CE, FM, RoHS, DFARS; UKCA	CE, FM, ATEX, RoHS, DFARS; UKCA
Warranty	Lifetime	Lifetime	Lifetime	Lifetime

*When used with an I/O processor (brain or on-the-rack controller), the processor requires 5.0 to 5.2 VDC.

SNAP-IDC5, SNAP-IDC5D, and SNAP-IDC5HT

	SNAP-IDC5	SNAP-IDC5D	SNAP-IDC5G (Obsolete)	SNAP-IDC5-HT
Key Feature	--	--	--	Leakage-tolerant
Wire size	22 to 14 AWG	22 to 14 AWG	22 to 14 AWG	22 to 14 AWG
Torque, hold-down screws	Not to exceed 1 in-lb (0.11 N-m)	Not to exceed 1 in-lb (0.11 N-m)	Not to exceed 1 in-lb (0.11 N-m)	Not to exceed 1 in-lb (0.11 N-m)
Torque, connector screws	5.22 in-lb (0.59 N-m)	5.22 in-lb (0.59 N-m)	5.22 in-lb (0.59 N-m)	5.22 in-lb (0.59 N-m)
Field Side Ratings (each channel)				
Nominal Input Voltage	24 VAC/VDC	5 VDC	48 VAC/VDC	24 VAC/VDC
Channel-to-channel isolation	300 VAC (1,500 V transient)	300 VAC (1,500 V transient)	300 VAC (1,500 V transient)	300 VAC (1,500 V transient)
Input Voltage Range	10–32 VAC/VDC	2.5–28 VDC	35–75 VAC/VDC	15–32 VAC/VDC
Turn-on Voltage	10 VAC/VDC	2.5 VDC	35 VAC/VDC	15 VAC/VDC
Turn-off Voltage	3 VAC/VDC	1 VDC	7 VAC/VDC	8 VAC/VDC
Input Resistance	15 K ohms (nominal)	3 K ohms (nominal)	64 K ohms (nominal)	3 K ohms (nominal)
Logic Side Ratings				
Logic Output Voltage	<.5 V max. (on) @ 2 mA sinking 2.7 V min. (off) @ 0.4 mA sourcing	<.5 V max. (on) @ 2 mA sinking 2.7 V min. (off) @ 0.4 mA sourcing	<.5 V max. (on) @ 2 mA sinking 2.7 V min. (off) @ 0.4 mA sourcing	<.5 V max. (on) @ 2 mA sinking 2.7 V min. (off) @ 0.4 mA sourcing
Logic Supply Voltage***	5 VDC ± 0.25 VDC	5 VDC ± 0.25 VDC	5 VDC ± 0.25 VDC	5 VDC ± 0.25 VDC
Logic Supply Current	50 mA maximum	50 mA maximum	50 mA maximum	50 mA maximum
Negative True Logic Output Drive	TTL 74 Series = 1 UL TTL 74LS Series = 5 UL	TTL 74 Series = 1 UL TTL 74LS Series = 5 UL	TTL 74 Series = 1 UL TTL 74LS Series = 5 UL	TTL 74 Series = 1 UL TTL 74LS Series = 5 UL
Module Ratings				
Number of Channels Per Module	4	4	4	4
Turn-on Time	5 msec	1 msec	5 msec	20 msec
Turn-off Time	15 msec	1 msec	15 msec	25 msec
Optical Isolation (Field Side to Logic Side)	4,000 volts (transient)	4,000 volts (transient)	4,000 volts (transient)	4,000 volts (transient)
Temperature	-20 to 70 °C, operating -40 to 85 °C, storage	-20 to 70 °C, operating -40 to 85 °C, storage	-20 to 70 °C, operating -40 to 85 °C, storage	-20 to 70 °C, operating -40 to 85 °C, storage
Agency Approvals	UL, CE, CSA, RoHS, DFARS, NEBS; UKCA	UL, CE, CSA, RoHS, DFARS; UKCA	UL, CE, RoHS, DFARS; UKCA	CE, RoHS, DFARS; UKCA
Warranty	Lifetime	Lifetime	Lifetime	Lifetime

* At 20kHz, 5Vp-p square wave input, 50% duty cycle.

** At 20kHz, 28Vp-p square wave input, 50% duty cycle.

*** When used with an I/O processor (brain or on-the-rack controller), the processor requires 5.0 to 5.2 VDC.

SNAP-IDC5-FAST, SNAP-IDC5-FAST-A, and SNAP-IDC5MA

	SNAP-IDC5-FAST*	SNAP-IDC5-FAST-A**	SNAP-IDC5MA
Key Feature	High-speed	High-speed	Diagnostic switches
Wire size	22 to 14 AWG	22 to 14 AWG	22 to 14 AWG
Torque, hold-down screws	Not to exceed 1 in-lb (0.11 N-m)	Not to exceed 1 in-lb (0.11 N-m)	Not to exceed 1 in-lb (0.11 N-m)
Torque, connector screws	5.22 in-lb (0.59 N-m)	5.22 in-lb (0.59 N-m)	5.22 in-lb (0.59 N-m)
Field Side Ratings (each channel)			
Nominal Input Voltage	5 VDC	28 VDC	24 VAC/VDC
Channel-to-channel isolation	300 VAC (1,500 V transient)	300 VAC (1,500 V transient)	300 VAC (1,500 V transient)
Input Voltage Range	2.5–16 VDC	18–32 VDC	10–32 VAC/VDC
Turn-on Voltage	2.5 VDC	18 VDC	10 VAC/VDC
Turn-off Voltage	1 VDC	5 VDC	3 VAC/VDC
Input Resistance	440 ohms (nominal)	8 K ohms (nominal)	15 K ohms (nominal)
Logic Side Ratings			
Logic Output Voltage	<0.5 V max. (on) @ 2 mA sinking 2.7 V min. (off) @ 0.4 mA sourcing	<0.5 V max. (on) @ 2 mA sinking 2.7 V min. (off) @ 0.4 mA sourcing	<0.5 V max. (on) @ 2 mA sinking 2.7 V min. (off) @ 400 mA sourcing
Logic Supply Voltage***	5 VDC ± 0.25 VDC	5 VDC ± 0.25 VDC	5 VDC ± 0.25 VDC
Logic Supply Current	50 mA maximum	50 mA maximum	50 mA maximum
Negative True Logic Output Drive	TTL 74 Series = 1 UL TTL 74LS Series = 5 UL	TTL 74 Series = 1 UL TTL 74LS Series = 5 UL	TTL 74 Series = 1 UL TTL 74LS Series = 5 UL
Module Ratings			
Number of Channels Per Module	4	4	4
Turn-on Time	0.025 msec*	0.025 msec**	5 msec
Turn-off Time	0.025 msec*	0.025 msec**	15 msec
Optical Isolation (Field Side to Logic Side)	4,000 volts (transient)	4,000 volts (transient)	4,000 volts (transient)
Temperature	-20 °C to 70 °C, operating -40 °C to 85 °C, storage	-20 °C to 70 °C, operating -40 °C to 85 °C, storage	-20 °C to 70 °C, operating -40 °C to 85 °C, storage
Agency Approvals	UL, CE, ATEX, FM, CSA, RoHS, DFARS; UKCA	UL, CE, CSA, RoHS, DFARS; UKCA	CE, RoHS, DFARS; UKCA
Warranty	Lifetime	Lifetime	30 months

* At 20kHz, 5Vp-p square wave input, 50% duty cycle.

** At 20kHz, 28Vp-p square wave input, 50% duty cycle.

*** When used with an I/O processor (brain or on-the-rack controller), the processor requires 5.0 to 5.2 VDC.

SNAP-IDC5Q

Logic Voltage	5 VDC
Operating Ambient Temperature	-20 to 70 °C
Isolation input-to-output	4,000 Vrms
Input Voltage Range	4–24 VDC
Input Resistance	1K ohms @ 4 V 560 ohms @ 24 V
Input Allowed for No Output	1 V
Logic Supply Current @ 5 VDC	120 mA
Maximum Input Frequency, 50% Duty Cycle	25 kHz for SNAP PAC brains and controllers with high-speed digital functions Legacy brains vary*
Maximum Reverse Input Voltage	–21 V
Torque, hold-down screws	Not to exceed 1 in-lb (0.11 N-m)
Torque, connector screws	5.22 in-lb (0.59 N-m)
Agency Approvals	CE, ATEX, FM, RoHS, DFARS; UKCA
Warranty	Lifetime

* The SNAP-IDC5Q supports an encoder input frequency of 25 kHz. However, legacy I/O brains have limited quadrature counting capability. The following limits apply to them:
2.5 kHz for SNAP-B3000-ENET brains
4 kHz for SNAP-UP1-ADS brains
5 kHz for other legacy brains with high-speed counting

SNAP-IDC5-SW and SNAP-IDC5-SW-NC

Field Side Ratings (each channel)	
Open Circuit Voltage (Switch Open)	15 VDC typical
Short Circuit Current (Switch Closed)	7 milliamps nominal
Minimum Off Resistance	>20 K ohms
Maximum Allowable On Resistance (Wire + Contact Resistance)	500 ohms
Logic Side Ratings	
Logic Output Voltage for SNAP-IDC5-SW (normally open)	<0.5 V max. (switch closed; LED on) @ 2 mA sinking 2.7 V min. (switch open; LED off) @ 0.4 mA sourcing
Logic Output Voltage for SNAP-IDC5-SW-NC (normally closed)	<0.5 V max. (switch closed; LED off) @ 2 mA sinking 2.7 V min. (switch open; LED on) @ 0.4 mA sourcing
Maximum Operating Common Mode Voltage (Field Term to Logic Connector)	250 V
Power Requirements	5 VDC (±0.25) @ 200 mA
Module Ratings	
Number of Channels Per Module	4
Turn-on Time	5 msec
Turn-off Time	25 msec
Channel-to-channel Isolation	None
Input-to-output Isolation	1500 V AC/DC
Wire size	22 to 14 AWG
Torque, hold-down screws	Not to exceed 1 in-lb (0.11 N-m)
Torque, connector screws	5.22 in-lb (0.59 N-m)
Temperature	-20 °C to 70 °C, operating -40 °C to 85 °C, storage
Agency Approvals	UL, CE, RoHS, DFARS; UKCA FM (SNAP-IDC5SW only)
Warranty	Lifetime

SNAP-IDC-32, SNAP-IDC-32-FM, SNAP-IDC-32N, SNAP-IDC-32D, and SNAP-IDC-32DN

	SNAP-IDC-32 SNAP-IDC-32-FM	SNAP-IDC-32N	SNAP-IDC-32D	SNAP-IDC-32DN
Input Range	10 to 32 VDC	-10 to -32 VDC	2.5 to 12 VDC	-2.5 to -12 VDC
Nominal Voltage Range	24 VDC	-12 to -24 VDC	2.5 VDC	-2.5 VDC
Input Resistance	20 K ohms	20 K ohms	3 K ohms	3 K ohms
Logic Voltage and Current	5 VDC \pm 0.1 @ 150 mA		5 VDC \pm 0.1 @ 150 mA	
Maximum Operating Common Mode Voltage	250 V	250 V	250 V	250 V
Isolation: Field to Logic	1500 V	1500 V	1500 V	1500 V
Input Arrangement	32 input channels; 4 groups of 8 inputs each		32 input channels; 4 groups of 8 inputs each	
Common connection	Points in each group share a common negative connection.	Points in each group share a common positive connection.	Points in each group share a common negative connection.	Points in each group share a common positive connection.
Channel-to-Channel Isolation	No channel-to-channel isolation; 100 V group-to-group isolation		No channel-to-channel isolation; 100 V group-to-group isolation	
Hold-down screws	Torque: Not to exceed 1 in-lb (0.11 N-m)		Torque: Not to exceed 1 in-lb (0.11 N-m)	
Connector screws	Torque: 5.22 in-lb (0.59 N-m)		Torque: 5.26 in-lb (0.59 N-m)	
Maximum Number of HDD Modules on One Mounting Rack	16	16	16	16
Indicators	None; use optional OptoTerminal-G20 diagnostic display or breakout rack.			
ON Voltage	10 VDC @ 0.5 mA	-10 VDC @ 0.5 mA	2.5 VDC @ 0.5 mA	-2.5 VDC @ 0.5 mA
OFF Voltage	3 VDC @ 0.1 mA	-3 VDC @ 0.1 mA	1 VDC @ 0.1 mA	-1 VDC @ 0.1 mA
Polling time from I/O processor to module ¹	2–30 ms typical ²	2–30 ms typical ²	2–30 ms typical ²	2–30 ms typical ²
Input Turn-On/Off Time	6 ms	6 ms	6 ms	6 ms
Counting Frequency (DC input)	0–50 Hz @ 50% duty cycle	0–50 Hz @ 50% duty cycle	0–50 Hz @ 50% duty cycle	0–50 Hz @ 50% duty cycle
Operating Temperature	-20 to 70 °C	-20 to 70 °C	-20 to 70 °C	-20 to 70 °C
Storage Temperature	-40 to 85 °C	-40 to 85 °C	-40 to 85 °C	-40 to 85 °C
Agency Approvals	UL, CE, RoHS, DFARS; UKCA FM (-FM model only)	CE, RoHS, DFARS	CE, RoHS, DFARS	CE, RoHS, DFARS
Warranty	Lifetime	Lifetime	Lifetime	Lifetime

¹ Affects turn-on and turn-off determination

² Time varies based on the SNAP PAC I/O processor (brain or on-the-rack controller), processor configuration, and Ethernet host communication activity.

SNAP-IDC-16, SNAP-IDC-HT-16, SNAP-IAC-16

	SNAP-IDC-16	SNAP-IDC-HT-16	SNAP-IAC-16	SNAP-IAC-A-16 (Obsolete)	SNAP-IAC-K-16 (Obsolete)
Input Range	10–32 VDC/VAC	15–28 VDC/VAC	90–140 VAC/VDC	180–280 VAC/VDC	70–130 VAC/VDC
Nominal Voltage Range	24 VDC	24 VDC	120 VAC	240 VAC	100 VAC
Input Resistance	44 K ohms	4 K ohms	300 K ohms	940 K ohms	220 K ohms
Logic Voltage and Current	5 VDC ± 0.1 @ 150 mA	5 VDC ± 0.1 @ 150 mA	5 VDC ± 0.1 @ 150 mA	5 VDC ± 0.1 @ 150 mA	5 VDC ± 0.1 @ 150 mA
Input Arrangement	16 isolated input channels			16 isolated input channels	
Channel-to-Channel Isolation	250 V steady-state, 1500 V transient			250 V steady-state, 1500 V transient	
Maximum Operating Common Mode Voltage	250 V	250 V	250 V	250 V	250 V
Isolation: Field to Logic	1500 V	1500 V	1500 V	1500 V	1500 V
Maximum Number of HDD Modules on One Mounting Rack	16	16	16	16	16
Indicators	None; use optional OptoTerminal-G20 diagnostic display.		None; use optional OptoTerminal-G20 diagnostic display.		
ON Voltage	10 VDC @ 0.230 mA	15 VDC @ 3.50 mA	90 VAC/VDC @ 0.3 mA	180 VAC/VDC @ 0.191 mA	70 VAC/VDC @ 0.3 mA
OFF Voltage	3 VDC @ 0.05 mA	9 VDC @ 2.0 mA	40 VAC/VDC @ 0.135 mA	40 VAC/VDC @ 0.043 mA	30 VAC/VDC @ 0.135 mA
Torque, hold-down screws	Not to exceed 1 in-lb (0.11 N-m)	Not to exceed 1 in-lb (0.11 N-m)	Not to exceed 1 in-lb (0.11 N-m)	Not to exceed 1 in-lb (0.11 N-m)	Not to exceed 1 in-lb (0.11 N-m)
Torque, connector screws	5.22 in-lb (0.59 N-m)	5.22 in-lb (0.59 N-m)	5.22 in-lb (0.59 N-m)	5.22 in-lb (0.59 N-m)	5.22 in-lb (0.59 N-m)
Polling time from I/O processor to module ¹	2–30 ms typical ²	2–30 ms typical ²	2–30 ms typical ²	2–30 ms typical ²	2–30 ms typical ²
Input Turn-On/Off Time	15 ms turn-on time 20 ms turn-off time	20 ms turn-on time 25 ms turn-off time	15 ms turn-on time 20 ms turn-off time	15 ms turn-on time 20 ms turn-off time	15 ms turn-on time 20 ms turn-off time
Counting Frequency (DC input)	0–25 Hz @ 50% duty cycle	0–15 Hz @ 50% duty cycle	0–25 Hz @ 50% duty cycle	0–25 Hz @ 50% duty cycle	0–25 Hz @ 50% duty cycle
Operating Temperature	-20 to 70 °C	-20 to 70 °C	-20 to 70 °C	-20 to 70 °C	-20 to 70 °C
Storage Temperature	-40 to 85 °C	-40 to 85 °C	-40 to 85 °C	-40 to 85 °C	-40 to 85 °C
Agency Approvals	UL, CE, RoHS, DFARS; UKCA	CE, RoHS, DFARS	UL, CE, RoHS, DFARS; UKCA	UL, CE, RoHS, DFARS; UKCA	CE, RoHS, DFARS
Warranty	Lifetime	Lifetime	Lifetime	Lifetime	Lifetime

¹ Affects turn-on and turn-off determination

² Time varies based on the SNAP PAC I/O processor (brain or on-the-rack controller), processor configuration, and Ethernet host communication activity.

DIGITAL OUTPUT MODULE SPECIFICATIONS

SNAP-OAC5, SNAP-OAC5MA, and SNAP-OAC5-i

	SNAP-OAC5	SNAP-OAC5MA	SNAP-OAC5-i
Key Feature	--	Diagnostic switches Four isolated channels	Four isolated channels
Torque, hold-down screws	Not to exceed 1 in-lb (0.11 N-m)	Not to exceed 1 in-lb (0.11 N-m)	Not to exceed 1 in-lb (0.11 N-m)
Torque, connector screws	5.22 in-lb (0.59 N-m)	5.22 in-lb (0.59 N-m)	5.22 in-lb (0.59 N-m)
Field Side Ratings (each channel)			
Line Voltage - Range	12–250 VAC	12–250 VAC	12–250 VAC
Line Voltage - Nominal	120/240 VAC	120/240 VAC	120/240 VAC
Current Rating 0 °C to 70 °C Ambient	3 amps per module	3 amps per module	3 amps per module
One Cycle Surge	80 amps peak (50/60 Hz)	80 amps peak (50/60 Hz)	80 amps peak (50/60 Hz)
Minimum Load Current	20 mA	20 mA	20 mA
Output Voltage Drop	1.6 volts max.@ 0.75 amps	1.6 volts max.@ 0.75 amps	1.6 volts max.@ 0.75 amps
Off-state Leakage at Nominal Voltage - 60 Hz	2.5 mA @ 240 VAC 1.25 mA @ 120 VAC	2.5 mA @ 240 VAC 1.25 mA @ 120 VAC	2.5 mA @ 240 VAC 1.25 mA @ 120 VAC
Peak Blocking Voltage	500 V	500 V	500 V
Operating Frequency	25–65 Hz	25–65 Hz	25–65 Hz
dV/ dt - Off-state	200 volts/msec	200 volts/msec	200 volts/msec
dV/ dt - Commutating	Snubbed for rated 0.5 power factor load	Snubbed for rated 0.5 power factor load	Snubbed for rated 0.5 power factor load
Fuse (Common to all Channels)	250 VAC - 4A 5x20 mm Fast-acting Bell Fuse Part: BEL 5HF4 Opto 22 Part: SNAP-FUSE4AB	Has four isolated channels. User must provide own fusing.	Has four isolated channels. User must provide own fusing.
Channel-to-channel isolation	Not applicable	300 VAC (1500 V transient)	300 VAC (1500 V transient)
Logic Side Ratings			
Pickup Voltage	4 V @ 5.5 mA	4 V @ 5.5 mA	4 V @ 5.5 mA
Dropout Voltage	1 VDC	1 VDC	1 VDC
Control Resistance	220 ohms	220 ohms	220 ohms
Logic Supply Voltage	5 VDC ± 0.25 VDC	5 VDC ± 0.25 VDC	5 VDC ± 0.25 VDC
Logic Supply Current	50 mA maximum	50 mA maximum	50 mA maximum
Module Ratings			
Number of Channels Per Module	4	4	4
Turn-on Time	0.5 cycle maximum (zero volts crossover)	0.5 cycle maximum (zero volts crossover)	0.5 cycle maximum (zero volts crossover)
Turn-off Time	0.5 cycle maximum (zero current crossover)	0.5 cycle maximum (zero current crossover)	0.5 cycle maximum (zero current crossover)
Isolation (Field Side to Logic Side)	4,000 volts (transient)	4,000 volts (transient)	4,000 volts (transient)
Temperature	-20 ° to 70 °C, operating -40 ° to 85 °C, storage	-20 ° to 70 °C, operating -40 ° to 85 °C, storage	-20 ° to 70 °C, operating -40 ° to 85 °C, storage
Wire size range	22 to 14 AWG	22 to 14 AWG	22 to 14 AWG
Agency Approvals	UL, CE, CSA, RoHS, DFARS; UKCA	UL, CE, RoHS, DFARS; UKCA	UL, CE, RoHS, DFARS; UKCA
Warranty	Lifetime	30 months	Lifetime

SNAP-ODC5SNK, SNAP-ODC5SRC

	SNAP-ODC5SRC	SNAP-ODC5SNK
Key Feature	Load sourcing	Load sinking
Torque, hold-down screws	Not to exceed 1 in-lb (0.11 N-m)	Not to exceed 1 in-lb (0.11 N-m)
Torque, connector screws	5.22 in-lb (0.59 N-m)	5.22 in-lb (0.59 N-m)
Field Side Ratings (each channel)		
Line Voltage - Range	5–60 VDC	5–60 VDC
Line Voltage - Nominal	5–48 VDC	5–48 VDC
Current Rating 0 °C to 70 °C Ambient	3 amps per module	3 amps per module
Surge Current	5 amps peak for 1 second	5 amps peak for 1 second
Minimum Load	20 mA	20 mA
Output Voltage Drop	1.6 volts max.@ 0.75 amps	1.6 volts max.@ 0.75 amps
Off-state Leakage	1 mA @ 60 VDC	1 mA @ 60 VDC
Peak Blocking Voltage	60 VDC	60 VDC
Fuse (Common to all Channels)	250 VAC - 4A 5x20 mm Fast-acting Bell Fuse Part No. BEL 5HF4 Opto 22 Part SNAP-FUSE4AB	250 VAC - 4A 5x20 mm Fast-acting Bell Fuse Part No. BEL 5HF4 Opto 22 Part SNAP-FUSE4AB
Channel-to-channel isolation	Not applicable	Not applicable
Logic Side Ratings		
Pickup Voltage	4 V @ 5.5 mA	4 V @ 5.5 mA
Dropout Voltage	1 VDC	1 VDC
Control Resistance	220 ohms	220 ohms
Logic Supply Voltage	5 VDC ± 0.25 VDC	5 VDC ± 0.25 VDC
Logic Supply Current	50 mA maximum	50 mA maximum
Module Ratings		
Number of Channels Per Module	4	4
Turn-on Time	100 usec	100 usec
Turn-off Time	750 usec	750 usec
Isolation (Field Side to Logic Side)	4,000 volts (transient)	4,000 volts (transient)
Temperature	-20 to 70 °C, operating -40 to 85 °C, storage	-20 to 70 °C, operating -40 to 85 °C, storage
Wire size range	22 to 14 AWG	22 to 14 AWG
Agency Approvals	UL, CE, CSA, RoHS, DFARS; UKCA	UL, CE, CSA, RoHS, DFARS; UKCA
Warranty	Lifetime	Lifetime

SNAP-ODC5SNKFM, SNAP-ODC5SRCFM

	SNAP-ODC5SRCFM	SNAP-ODC5SNKFM
Key Feature	Factory Mutual approved	Factory Mutual approved
Torque, hold-down screws	Not to exceed 1 in-lb (0.11 N-m)	Not to exceed 1 in-lb (0.11 N-m)
Torque, connector screws	5.22 in-lb (0.59 N-m)	5.22 in-lb (0.59 N-m)
Field Side Ratings (each channel)		
Line Voltage - Range	5–60 VDC	5–60 VDC
Line Voltage - Nominal	5–48 VDC	5–48 VDC
Current Rating 0°C to 70°C Ambient	3 amps per module	3 amps per module
Surge Current	5 amps peak for 1 second	5 amps peak for 1 second
Minimum Load	20 mA	20 mA
Output Voltage Drop	1.6 volts max.@ 0.75 amps	1.6 volts max.@ 0.75 amps
Off-state Leakage	1 mA @ 60 VDC	1 mA @ 60 VDC
Peak Blocking Voltage	60 VDC	60 VDC
Fuse (Common to all Channels)	250 VAC - 4A 5x20 mm Fast-acting Bell Fuse Part No. BEL 5HF4 Opto 22 Part SNAP-FUSE4AB	250 VAC - 4A 5x20 mm Fast-acting Bell Fuse Part No. BEL 5HF4 Opto 22 Part SNAP-FUSE4AB
Logic Side Ratings		
Pickup Voltage	4 V @ 5.5 mA	4 V @ 5.5 mA
Dropout Voltage	1 VDC	1 VDC
Control Resistance	220 ohms	220 ohms
Logic Supply Voltage	5 VDC ± 0.25 VDC	5 VDC ± 0.25 VDC
Logic Supply Current	50 mA maximum	50 mA maximum
Module Ratings		
Number of Channels Per Module	4	4
Turn-on Time	100 usec	100 usec
Turn-off Time	750 usec	750 usec
Isolation (Field Side to Logic Side)	4,000 volts (transient)	4,000 volts (transient)
Temperature	-20 to 70 °C, operating -40 to 85 °C, storage	-20 to 70 °C, operating -40 to 85 °C, storage
Wire size range	22 to 14 AWG	22 to 14 AWG
Agency Approvals	CE, FM, RoHS, DFARS; UKCA	CE, FM, RoHS, DFARS; UKCA
Warranty	Lifetime	Lifetime

SNAP-ODC5R and SNAP-ODC5R5

	SNAP-ODC5R	SNAP-ODC5R5
Key Feature	Dry contact Normally open	Dry contact Normally closed
Torque, hold-down screws	Not to exceed 1 in-lb (0.11 N-m)	Not to exceed 1 in-lb (0.11 N-m)
Torque, connector screws	5.22 in-lb (0.59 N-m)	5.22 in-lb (0.59 N-m)
Field Side Ratings (each channel)		
Line Voltage - Range	0–100 VDC 0–130 VAC*	0–100 VDC 0–130 VAC*
Line Voltage - Nominal	--	--
Current Rating	0.5 amps switching*	0.5 amps switching*
Surge Current	0.5 amps*	0.5 amps*
Minimum Load	0 mA	0 mA
Output Voltage Drop	0 volts	0 volts
Off-state Leakage	0 mA	0 mA
Peak Blocking Voltage	100 VDC / 130 VAC	100 VDC / 130 VAC
Fuse (Common to all Channels)	Has four isolated channels. User must provide own fusing.	Has four isolated channels. User must provide own fusing.
Channel-to-channel isolation	300 VAC (1500 V transient)	300 VAC (1500 V transient)
Logic Side Ratings		
Pickup Voltage	4 V @ 5.5 mA	4 V @ 5.5 mA
Dropout Voltage	1 VDC	1 VDC
Control Resistance	220 ohms	220 ohms
Logic Supply Voltage	5 VDC ± 0.25 VDC	5 VDC ± 0.25 VDC
Logic Supply Current	50 mA maximum	50 mA maximum
Module Ratings		
Number of Channels Per Module	4	4
Turn-on Time	500 usec	500 usec
Turn-off Time	500 usec	500 usec
Isolation (Field Side to Logic Side)	1,500 volts (transient)	1,500 volts (transient)
Mechanical Life	200,000,000 cycles	200,000,000 cycles
Temperature	-20 to 70 °C, operating -30 to 85 °C, storage	-20 to 70 °C, operating -30 to 85 °C, storage
Agency Approvals	CE, CSA, RoHS, DFARS; UKCA	CE, RoHS, DFARS; UKCA
Warranty	30 months or mechanical life, whichever comes first	30 months or mechanical life, whichever comes first

* The current of the dry contact module must not exceed 10 VA power limit under steady state or momentary in-rush conditions. For voltages at or below 20 volts, the current limit is 0.5 amps. For voltages above 20 volts, the maximum allowable current is determined by the following equation: Current Maximum = 10 VA / Voltage. Rating curve is in the data sheet.

SNAP-ODC5RFM

	SNAP-ODC5RFM	SNAP-ODC5R5FM (Obsolete)
Key Feature	Factory Mutual approved	Factory Mutual approved
Torque, hold-down screws	Not to exceed 1 in-lb (0.11 N-m)	Not to exceed 1 in-lb (0.11 N-m)
Torque, connector screws	5.22 in-lb (0.59 N-m)	5.22 in-lb (0.59 N-m)
Field Side Ratings (each channel)		
Line Voltage - Range	0–100 VDC 0–130 VAC*	0–100 VDC 0–130 VAC*
Line Voltage - Nominal	--	--
Current Rating	0.5 amps switching*	0.5 amps switching*
Surge Current	0.5 amps*	0.5 amps*
Minimum Load	0 mA	0 mA
Output Voltage Drop	0 volts	0 volts
Off-state Leakage	0 mA	0 mA
Peak Blocking Voltage	100 VDC / 130 VAC	100 VDC / 130 VAC
Fuse (Common to all Channels)	Has four isolated channels. User must provide own fusing.	Has four isolated channels. User must provide own fusing.
Logic Side Ratings		
Pickup Voltage	4 V @ 5.5 mA	4 V @ 5.5 mA
Dropout Voltage	1 VDC	1 VDC
Control Resistance	220 ohms	220 ohms
Logic Supply Voltage	5 VDC ± 0.25 VDC	5 VDC ± 0.25 VDC
Logic Supply Current	50 mA maximum	50 mA maximum
Module Ratings		
Number of Channels Per Module	4	4
Turn-on Time	500 usec	500 usec
Turn-off Time	500 usec	500 usec
Isolation (Field Side to Logic Side)	1,500 volts (transient)	1,500 volts (transient)
Mechanical Life	200,000,000 cycles	200,000,000 cycles
Temperature	-20 to 70 °C, operating -30 to 85 °C, storage	-20 to 70 °C, operating -30 to 85 °C, storage
Agency Approvals	CE, FM, RoHS, DFARS; UKCA	CE, FM, RoHS, DFARS; UKCA
Warranty	30 months or mechanical life, whichever comes first	30 months or mechanical life, whichever comes first

* The current of the dry contact module must not exceed 10 VA power rating under steady state or momentary in-rush conditions. For voltages at or below 20 volts, the current limit is 0.5 amps. For voltages above 20 volts, the maximum allowable current is determined by the following equation: Current Maximum = 10 VA / Voltage. Rating curve is in the data sheet.

SNAP-ODC5-iFM

	SNAP-ODC5-iFM	SNAP-ODC5A-iFM (Obsolete)
Key Feature	Four isolated channels Factory Mutual approved	Four isolated channels Factory Mutual approved
Torque, hold-down screws	Not to exceed 1 in-lb (0.11 N-m)	Not to exceed 1 in-lb (0.11 N-m)
Torque, connector screws	5.22 in-lb (0.59 N-m)	5.22 in-lb (0.59 N-m)
Field Side Ratings (each channel)		
Line Voltage - Range	5–60 VDC	5–200 VDC
Line Voltage - Nominal	5–48 VDC	5–200 VDC
Current Rating 0°C to 70°C Ambient	3 amps per module	3 amps per module
Surge Current	5 amps peak for 1 second	5 amps peak for 1 second
Minimum Load	20 mA	20 mA
Output Voltage Drop	1.6 volts max. @ 0.75 amps	1.6 volts max. @ 0.75 amps
Off-state Leakage	1 mA @ 60 VDC	1 mA @ 60 VDC
Peak Blocking Voltage	60 VDC	200 VDC
Fuse (Common to all Channels)	Has four isolated channels. User must provide own fusing.	Has four isolated channels. User must provide own fusing.
Logic Side Ratings		
Pickup Voltage	4 V @ 5.5 mA	4 V @ 5.5 mA
Dropout Voltage	1 VDC	1 VDC
Control Resistance	220 ohms	220 ohms
Logic Supply Voltage	5 VDC ± 0.25 VDC	5 VDC ± 0.25 VDC
Logic Supply Current	50 mA maximum	50 mA maximum
Module Ratings		
Number of Channels Per Module	4	4
Turn-on Time	100 usec	100 usec
Turn-off Time	750 usec	750 usec
Isolation (Field Side to Logic Side)	4,000 volts (transient)	4,000 volts (transient)
Temperature	-20 ° to 70 °C, operating -40 ° to 85 °C, storage	-20 ° to 70 °C, operating -40 ° to 85 °C, storage
Wire size range	22 to 14 AWG	22 to 14 AWG
Agency Approvals	CE, FM, ATEX, RoHS, DFARS; UKCA	CE, FM, RoHS, DFARS; UKCA
Warranty	Lifetime	Lifetime

SNAP-ODC5MA, SNAP-ODC5-i, SNAP-ODC5A-i, and SNAP-ODC5ASNK

	SNAP-ODC5MA	SNAP-ODC5-i	SNAP-ODC5A-i	SNAP-ODC5ASNK
Key Feature	Diagnostic switches Four isolated channels	Four isolated channels	Four isolated channels	Load sinking
Torque, hold-down screws	Not to exceed 1 in-lb (0.11 N-m)	Not to exceed 1 in-lb (0.11 N-m)	Not to exceed 1 in-lb (0.11 N-m)	Not to exceed 1 in-lb (0.11 N-m)
Torque, connector screws	5.22 in-lb (0.59 N-m)	5.22 in-lb (0.59 N-m)	5.22 in-lb (0.59 N-m)	5.22 in-lb (0.59 N-m)
Field Side Ratings (each channel)				
Line Voltage - Range	5–60 VDC	5–60 VDC	5–200 VDC	5–200 VDC
Line Voltage - Nominal	5–48 VDC	5–48 VDC	5–200 VDC	5–200 VDC
Current Rating 0 °C to 70 °C Ambient	2 amps per module 0.5 amps per channel	3 amps per module	3 amps per module	3 amps per module
Surge Current	1.5 amps peak for 1 second	5 amps peak for 1 second	5 amps peak for 1 second	5 amps peak for 1 second
Minimum Load	20 mA	20 mA	20 mA	20 mA
Output Voltage Drop	1.6 volts max. @ 0.75 amps	1.6 volts max. @ 0.75 amps	1.6 volts max. @ 0.75 amps	1.6 volts max. @ 0.75 amps
Off-state Leakage	1 mA @ 60 VDC	1 mA @ 60 VDC	1 mA @ 200 VDC	1 mA @ 200 VDC
Peak Blocking Voltage	60 VDC	60 VDC	200 VDC	200 VDC
Fuse (Common to all Channels)	Has four isolated channels. User must provide own fusing.	Has four isolated channels. User must provide own fusing.	Has four isolated channels. User must provide own fusing.	250 VAC - 4A 5x20 mm Fast-acting Bell Fuse Part: BEL 5HF4 Opto 22 Part: SNAP-FUSE4AB
Channel-to-channel isolation	300 VAC (1500 V transient)	300 VAC (1500 V transient)	300 VAC (1500 V transient)	Not applicable
Logic Side Ratings				
Pickup Voltage	4 V @ 5.5 mA	4 V @ 5.5 mA	4 V @ 5.5 mA	4 V @ 5.5 mA
Dropout Voltage	1 VDC	1 VDC	1 VDC	1 VDC
Control Resistance	220 ohms	220 ohms	220 ohms	220 ohms
Logic Supply Voltage	5 VDC ± 0.25 VDC	5 VDC ± 0.25 VDC	5 VDC ± 0.25 VDC	5 VDC ± 0.25 VDC
Logic Supply Current	50 mA maximum	50 mA maximum	50 mA maximum	50 mA maximum
Module Ratings				
Number of Channels Per Module	4	4	4	4
Turn-on Time	100 usec	100 usec	100 usec	100 usec
Turn-off Time	750 usec	750 usec	750 usec	750 usec
Isolation (Field Side to Logic Side)	4,000 volts (transient)	4,000 volts (transient)	4,000 volts (transient)	4,000 volts (transient)
Temperature	-20 to 70 °C, operating -40 to 85 °C, storage	-20 to 70 °C, operating -40 to 85 °C, storage	-20 to 70 °C, operating -40 to 85 °C, storage	-20 to 70 °C, operating -40 to 85 °C, storage
Wire size range	22 to 14 AWG	22 to 14 AWG	22 to 14 AWG	22 to 14 AWG
Agency Approvals	UL, CE, RoHS, DFARS; UKCA	UL, CE, RoHS, DFARS; UKCA	UL, CE, RoHS, DFARS; UKCA	UL, CE, RoHS, DFARS; UKCA
Warranty	30 months	Lifetime	Lifetime	Lifetime

SNAP-ODC-32-SRC and SNAP-ODC-32-SNK

	SNAP-ODC-32-SRC SNAP-ODC-32-SRC-FM (obsolete)	SNAP-ODC-32-SNK SNAP-ODC-32-SNK-FM (obsolete)
Switching Voltage	5–60 VDC	5–60 VDC
Nominal Switching Voltage	12–24 VDC	12–24 VDC
Logic Voltage and Current	5 VDC ± 0.1 @ 150 mA	5 VDC ± 0.1 @ 150 mA
Maximum Off State Voltage	60 VDC	60 VDC
Output Leakage, Typical	<10 microamps per channel (60 V, 70 °C)	<10 microamps per channel (60 V, 70 °C)
Maximum Load per Point	0.25 A	0.25 A
Voltage Drop	0.15 VDC @ 0.25 A	0.15 VDC @ 0.25 A
Surge (1 sec.)	1 A	1 A
Output Arrangement	32 output channels; 4 groups of 8 outputs each. Points in each group share a common positive connection.	32 output channels; 4 groups of 8 outputs each. Points in each group share a common negative connection.
Maximum Operating Common Mode Voltage	250 V	250 V
Isolation: Field to Logic	1500 V	1500 V
Output Turn-On/Off Time	100 microseconds	100 microseconds
Polling time from I/O processor to module ¹	2–30 ms typical ²	2–30 ms typical ²
Indicators	None; use optional OptoTerminal-G20 diagnostic display or breakout rack.	None; use optional OptoTerminal-G20 diagnostic display or breakout rack.
Maximum Number of HDD Modules on One Mounting Rack	16	16
Torque, hold-down screws	Not to exceed 1 in-lb (0.11 N-m)	Not to exceed 1 in-lb (0.11 N-m)
Torque, connector screws	5.22 in-lb (0.59 N-m)	5.22 in-lb (0.59 N-m)
Operating Temperature	-20 to 70 °C	-20 to 70 °C
Storage Temperature	-40 to 85 °C	-40 to 85 °C
Agency Approvals	SNAP-ODC-32-SRC: UL, CE, RoHS, DFARS, UKCA SNAP-ODC-32-SRC-FM: CE, FM, RoHS, DFARS, UKCA	SNAP-ODC-32-SNK: UL, CE, RoHS, DFARS; UKCA SNAP-ODC-32-SNK-FM: CE, FM, RoHS, DFARS; UKCA
Warranty	Lifetime	Lifetime

¹ Affects turn-on and turn-off determination

² Time varies based on the SNAP PAC I/O processor (brain or on-the-rack controller), processor configuration, and Ethernet host communication activity.

SNAP-OMR6-C and SNAP-OMR6T-C

	SNAP-OMR6-C	SNAP-OMR6T-C
Field Side Ratings (each channel)		
Contact Configuration	Form C (SPDT, normally open or closed)	Form C (SPDT, normally open or closed)
Line Voltage - Range	0–250 VAC or 5–30 VDC	0–250 VAC or 5–30 VDC
Current Rating	6 amps switching @ 250 VAC / 30 VDC	6 amps switching @ 250 VAC / 30 VDC
Surge Current	6 amps	6 amps
Minimum Load	5 VDC, 10 mA	5 VDC, 10 mA
Contact Resistance	≤ 100 milliohms	≤ 100 milliohms
Leakage Current	none	< 1 microamp @ 250 VAC
Clamping Voltage (for transient suppression)	External transient suppression required	440 V nominal
Duty Cycle	-- Not applicable --	1 Hz
Switching Power	1500 VA / 144 W (DC)	1500 VA / 144 W (DC)
Peak Blocking Voltage	250 VAC @ 360 V _{pk}	250 VAC @ 360 V _{pk}
Channel-to-channel isolation	300 VAC (1500 Vtransient)	300 VAC (1500 Vtransient)
Logic Side Ratings		
Pickup Voltage	1 V @ 2 mA	1 V @ 2 mA
Dropout Voltage	4 VDC	4 VDC
Control Resistance	220 ohms	220 ohms
Logic Supply Voltage	5 VDC ± 0.25 VDC	5 VDC ± 0.25 VDC
Logic Supply Current	160 mA maximum	160 mA maximum
Module Ratings		
Number of Channels Per Module	4	4
Turn-on Time	8 milliseconds	8 milliseconds
Turn-off Time	8 milliseconds	8 milliseconds
Torque, hold-down screws	Not to exceed 1 in-lb (0.11 N-m)	Not to exceed 1 in-lb (0.11 N-m)
Torque, connector screws	Single gray connector: 5.22 in-lb (0.59 N-m) Black connectors: 1.7 in-lb (0.2 N-m)	5.22 in-lb (0.59 N-m)
Temperature	-20 to 70 °C, operating -30 to 85 °C, storage	-20 to 70 °C, operating -30 to 85 °C, storage
Agency Approvals	UL, CE, RoHS, DFARS; UKCA	UL, CE RoHS, DFARS
Mechanical Life	10 x 10 ⁶ operations	10 x 10 ⁶ operations
Operational Life	30 x 10 ³ operations	30 x 10 ³ operations
Warranty	30 months	30 months

ANALOG INPUT MODULE SPECIFICATIONS

SNAP-AIARMS

Input Range	0 to 10 amp RMS AC/DC
Input Over-Range	To 11 amps
Input Resistance	0.005 ohms
Maximum Input	11 amps AC/DC
Accuracy (AC)	±8 mA and ±0.2% reading
Resolution	400 microamps
DC Reversal	±16 mA (0.16%)
Input Response Time (Step Change)	63.2% (158 V) in 50 ms 99% (248 V) in 75 ms
Data Freshness (Max)	32.3 ms
DC Common Mode Rejection	>-120 dB
AC Common Mode Rejection	>-120 dB at 60 Hz
Maximum Operating Common Mode Voltage	250 V
Isolation	1500 V
Power Requirements	5 VDC (±0.15 V) at 170 mA
Operating Temperature	-20 °C to 70 °C
Storage Temperature	-40 °C to 85 °C
Humidity	5-95%, non-condensing
Wire size	22 to 14 AWG
Torque, hold-down screws	Not to exceed 1 in-lb (0.11 N-m)
Torque, connector screws	5.22 in-lb (0.59 N-m)
Agency Approvals	UL, FM, CE, RoHS, DFARS; UKCA, NEBS
Warranty	Lifetime

SNAP-AIARMS-i

Input Range	0 to 10 amp RMS AC/DC
Input Over Range	To 11 amps
Input Resistance	0.005 ohms
Maximum Input	11 amps AC/DC
Accuracy (AC)	±8 mA and ±0.2% reading
Resolution	400 µA
DC Reversal	±16 mA (0.16%)
Input Response Time (Step Change)	63.2% (6.32 A) in 50 ms 99% (9.92 A) in 75 ms
Data Freshness (Max)	0.025 ms
DC Common Mode Rejection	>-120 dB
AC Common Mode Rejection	>-120 dB at 60 Hz
Maximum Operating Voltage Between Channels Common Mode Voltage	250 V 250 V
Isolation: Optical	4000 V
Isolation: Transformer	1500 V
Isolation: Channel to Channel	250 V continuous (1500 V transient)
Power Requirements	5 VDC (±0.15 V) at 200 mA
Ambient Temperature: Operating Storage	-20 °C to 70 °C -40 °C to 85 °C
Humidity	5-95%, non-condensing
Torque, hold-down screws	Not to exceed 1 in-lb (0.11 N-m)
Torque, connector screws	5.22 in-lb (0.59 N-m)
Wire size range	22 to 14 AWG
Agency Approvals	CE, RoHS, DFARS; UKCA FM (SNAP-AIARMS-FM only)
Warranty	Lifetime

SNAP-AILC and SNAP-AILC-2

Input Range Sensitivity:	
SNAP-AILC	2 mV/V or 3 mV/V (Over range ± 2.2 mV or ± 3.3 mV)
SNAP-AILC-2	3 mV/V or 4 mV/V (Over range ± 3.3 mV or ± 4.4 mV)
Input Resistance	100 Megohms differential
Resolution: Analog Scale Points	>22 bits + sign ($\pm 6,400,000$ counts = $\pm 100\%$ of scale)
Response Time, Data Freshness	See the following table
DC Reversal (Input)	0.015% (± 1000 counts of reading @ 6,400,000 F.S.)
DC Common Mode Rejection	>-120 dB
AC Common Mode Rejection	>-120 dB @ 60 Hz
Maximum Survivable Input	± 15 volts across module load cell connector
Maximum Operating Common Mode Voltage	250 V
Accuracy (% Full Scale):	
Offset	$\pm 0.05\%$ (= 3,200 counts out of 6,400,000, out of box)
Gain	$\pm 0.05\%$ (= 3,200 counts out of 6,400,000, out of box)
Usable Resolution at Default Configuration (Fast)	38 nV - sign and 19 bits ($\pm 524,288$ counts @ channel 2) At filter weight 64, settles to 99.9% of final reading in 3.9 s.
DRIFT:	
Gain	40 PPM / °C
Offset	10 PPM / °C
Isolation: Optical	4000 V
Isolation: Transformer	1500 V
Rack Power Requirements	5.00 VDC to 5.20 VDC @ 120 mA
24V Bridge Supply:	
Input Voltage	24 VDC nominal (22 V min. to 30 V max.)
Input Current	40 mA for one load cell or 115 mA for four load cells
Output Fault Current	124 mA typical (field fault—shorted bridge)
Ambient Temperature:	
Operating	-20 to 70 °C
Storage	-40 to 85 °C
Humidity	5-95%, non-condensing
Wire size	22 to 14 AWG
Torque, hold-down screws	Not to exceed 1 in-lb (0.11 N-m)
Torque, connector screws	5.22 in-lb (0.59 N-m)
Agency Approvals	CE, RoHS, DFARS
Warranty	Lifetime

SNAP-AICTD and SNAP-AICTD-4

Input Range with ICTD Probe	-40 °C to +100 °C
Module Input Range Zero Scale Full Scale	-273 °C +150 °C
Resolution	0.017 °C
Accuracy with ICTD Probe	±0.8 °C
Sensitivity	1.0 microamps/ °C
Data Freshness (Max)	167 ms (2-channel module) 355 ms (4-channel module)
DC Common Mode Rejection	>-120 dB
AC Common Mode Rejection	>-120 dB @ 60 Hz
Maximum Operating Common Mode Voltage	250 V
Isolation	1500 V
Power Requirements	5 VDC (± .015) @ 150 mA
Operating Temperature	-20 °C to 70 °C
Storage Temperature	-40 °C to 85 °C
Humidity	5-95%, non-condensing
Wire size	22 to 14 AWG
Torque, hold-down screws	Not to exceed 1 in-lb (0.11 N-m)
Torque, connector screws	5.22 in-lb (0.59 N-m)
Agency Approvals	UL, FM, CE, RoHS, DFARS; UKCA
Warranty	Lifetime

SNAP-AICTD-8

Input Range with ICTD Probe	-40 °C to +100 °C
Module Input Range Zero Scale Full Scale	-273 °C +150 °C
Data Freshness (Max)	0.28 seconds
Resolution	0.017 °C
Accuracy with ICTD Probe	±0.8 °C
Sensitivity	1.0 mA/ °C
DC Common Mode Rejection	>-120 dB
AC Common Mode Rejection	>-120 dB @ 60 Hz
Maximum Operating Common Mode Voltage	250 V
Isolation	1500 V
Power Requirements	5 VDC (± .015) @ 170 mA
Operating Temperature	-20 °C to 70 °C
Storage Temperature	-40 °C to 85 °C
Humidity	5-95%, non-condensing
Torque, hold-down screws	Not to exceed 1 in-lb (0.11 N-m)
Torque, connector screws	1.7 in-lb (0.19 N-m)
Agency Approvals	CE, RoHS, DFARS; UKCA
Warranty	Lifetime

SNAP-AIMA and SNAP-AIMA-4

Input Range	-20 mA to +20 mA
Resolution	0.8 microamps
Over-Range Limits	From -22 to +22 mA (+/-20 mA range)
Input Response Time (% of span/ delta I/delta tme)	99.9% / 19.9 mA / 10 ms
Data Freshness (Max)	SNAP-AIMA: 11.5 ms SNAP-AIMA-4: 23 ms
DC Common Mode Rejection	>-120 dB
AC Common Mode Rejection	>-120 dB @ 60 Hz
Maximum Survivable Input	36 mA or 9 VDC
Maximum Operating Common Mode Voltage	250 V
Accuracy	0.05% (10 microamps)
DRIFT: Gain Temperature Coefficient	30 PPM/ °C
DRIFT: Offset Temperature Coefficient	15 PPM/ °C
Power Requirements	5 VDC (±0.15) @ 170 mA
Input Resistance - Single Ended	200 ohms (each channel)
Operating Temperature	-20 °C to 70 °C
Storage Temperature	-40 °C to 85 °C
Humidity	5-95%, non-condensing
Torque, hold-down screws	Not to exceed 1 in-lb (0.11 N-m)
Torque, connector screws	5.22 in-lb (0.59 N-m)
Wire size	22 to 14 AWG
Agency Approvals	UL, FM, CE, RoHS, DFARS; UKCA ATEX (SNAP-AIMA-4 only) NEBS (SNAP-AIMA only)
Warranty	Lifetime

SNAP-AIMA-8

Input Range	-20 mA to +20 mA
Over-Range Limits	From -22 to +22 mA (+/-20 mA range)
Resolution	0.8 microamps
Data Freshness (Max)	0.28 seconds
DC Common Mode Rejection	>-120 dB
AC Common Mode Rejection	>-120 dB @ 60 Hz
Maximum Survivable Input	36 mA or 9 VDC
Maximum Operating Common Mode Voltage	250 V
Accuracy	0.05% (10 microamps)
DRIFT: Gain Temperature Coefficient	30 PPM/ °C
DRIFT: Offset Temperature Coefficient	15 PPM/ °C
Isolation	1500 V
Power Requirements	5 VDC (±0.15) @ 170 mA
Input Resistance - Single Ended	100 ohms (all channels share the same reference point)
Operating Temperature	-20 °C to 70 °C
Storage Temperature	-40 °C to 85 °C
Humidity	5-95%, non-condensing
Torque, hold-down screws	Not to exceed 1 in-lb (0.11 N-m)
Torque, connector screws	1.7 in-lb (0.19 N-m)
Agency Approvals	CE, RoHS, DFARS
Warranty	Lifetime

SNAP-AIMA-32

Input Range	-20 mA to +20 mA
Over-Range Limits	From -22 to +22 mA (+/-20 mA range)
Resolution	0.8 microamps
Input Filtering	-3 dB @ 31 Hz
Data Freshness (Max)	1.15 s
DC Common Mode Rejection	>-120 dB
AC Common Mode Rejection	>-120 dB @ 60 Hz
Maximum Survivable Input	36 mA or 9 VDC
Maximum Operating Common Mode Voltage	250 V
Accuracy	0.1% (20 microamps)
DRIFT: Gain Temperature Coefficient	30 PPM/ °C
DRIFT: Offset Temperature Coefficient	15 PPM/ °C
Isolation	1500 V, field to logic
Power Requirements	5 VDC (±0.15) @ 150 mA
Input Resistance - Single Ended	100 ohms (each channel)
Operating Temperature	-20 °C to 70 °C
Storage Temperature	-40 °C to 85 °C
Humidity	5-95%, non-condensing
Torque, hold-down screws	Not to exceed 1 in-lb (0.11 N-m)
Torque, connector screws	5.22 in-lb (0.59 N-m)
Agency Approvals	SNAP-AIMA-32: UL, CE, RoHS, DFARS; UKCA. SNAP-AIMA-32-FM: CE, FM, RoHS, DFARS; UKCA
Warranty	Lifetime

SNAP-AIMA2-i

Input Range	-1 mA to +1mA
Maximum Over Range	± 10% (= ± 27500 counts)
Resolution	0.04 µA
Input Response Time (% of span/delta I/delta time)	99.9 %/19.9 µA/10 ms
Data Freshness	11 ms
DC Common Mode Rejection	>-120 dB
AC Common Mode Rejection	>-120 dB @ 60 Hz
Maximum Survivable Input	11 mA or 28 VDC
Maximum Operating Common Mode Voltage	250 V
Accuracy	0.05% (0.05 µA)
DRIFT: Gain Temperature Coefficient	30 PPM/ °C
DRIFT: Offset Temperature Coefficient	15 PPM/ °C
Isolation: Optical	4000 V
Isolation: Transformer	1500 V
Isolation: Channel to Channel	250 V continuous (1500 V transient)
Power Requirements	5 VDC (±0.15) @ 200 mA
Input Resistance	5 K ohms (each channel)
Ambient Temperature: Operating	-20 °C to 70 °C
Storage	-40 °C to 85 °C
Humidity	5-95%, non-condensing
Torque, hold-down screws	Not to exceed 1 in-lb (0.11 N-r)
Torque, connector screws	5.22 in-lb (0.59 N-m)
Wire size range	22 to 14 AWG
Agency Approvals	CE, RoHS, DFARS
Warranty	Lifetime

SNAP-AIMA-i

Input Range	-20 mA to +20 mA
Maximum Over Range	± 10% (= ± 27500 counts)
Resolution	0.8 µA
Input Response Time (% of span/delta I/delta time)	99.9 %/19.9 µA/10 mS
Data Freshness	11 ms
DC Common Mode Rejection	>-120 dB
AC Common Mode Rejection	>-120 dB @ 60 Hz
Maximum Survivable Input	36 mA or 9 VDC
Maximum Operating Common Mode Voltage	250 V
Accuracy	0.05% (10 µA)
Isolation: Optical	4000 V
Isolation: Transformer	1500 V
Isolation: Channel to Channel	250 V continuous (1500 V transient)
DRIFT: Gain Temperature Coefficient	30 PPM/ °C
DRIFT: Offset Temperature Coefficient	15 PPM/ °C
Power Requirements	5 VDC (±0.15) @ 200 mA
Input Resistance - Single Ended	200 ohms (each channel)
Ambient Temperature: Operating	-20 °C to 70 °C
Storage	-40 °C to 85 °C
Humidity	5-95%, non-condensing
Torque, hold-down screws	Not to exceed 1 in-lb (0.11 N-m)
Torque, connector screws	5.22 in-lb (0.59 N-m)
Wire size range	22 to 14 AWG
Agency Approvals	UL, CE, FM, RoHS, DFARS; UKCA
Warranty	Lifetime

SNAP-AIMA-iSRC and SNAP-AIMA-iSRC-FM

Input Range	0 to +20 mA with loop sourcing -20 mA to +20 mA
Maximum Over Range	± 10% (= ± 27500 counts)
Resolution	0.8 µA
Input Response Time (% of span/delta I/delta time)	99.9 %/19.9 mA/10 ms
Data Freshness	11 ms
DC Common Mode Rejection	>-120 dB
AC Common Mode Rejection	>-120 dB @ 60 Hz
Maximum Survivable Input	36 mA or 9 VDC
Maximum Operating Common Mode Voltage	250 V
Accuracy	0.05% (10 µA)
DRIFT: Gain Temperature Coefficient	30 PPM/ °C
DRIFT: Offset Temperature Coefficient	15 PPM/ °C
Isolation: Optical	4000 V
Isolation: Transformer	1500 V
Isolation: Channel to Channel	250 V continuous (1500 V transient)
Power Requirements	5 VDC (±0.15) @ 200 mA
Power Requirements - Loop Power (Input)	From separate field connector: 24 VDC nominal (70 mA max @ 24 V input, both loops @ 20 mA), 30 VDC maximum
Loop Power (Output)	24 VDC (± 1.5 V) @ 20 mA Open loop: 30 V maximum Shorted loop: 24 mA nominal
LED on top of module	Indicates that there is power to the 24v source supply 2-pin connector
Input Resistance	200 ohms (each channel)
Ambient Temperature: Operating	-20 °C to 70 °C
Storage	-40 °C to 85 °C
Humidity	5-95%, non-condensing
Torque, hold-down screws	Not to exceed 1 in-lb (0.11 N-m)
Torque, connector screws	5.22 in-lb (0.59 N-m)
Wire size range	22 to 14 AWG
Agency Approvals	CE, RoHS, DFARS; UKCA FM (SNAP-AIMA-iSRC-FM only)
Warranty	Lifetime

SNAP-AIRATE

Nominal Input Range	0 to 25,000 Hz
Input Over-Range	To 27,500 Hz
Resolution	1 Hz
Input Response Time(% of span / delta Hz / delta time)	10.0% / 2,500 Hz / 0.1 sec 63.2% / 15.8 K Hz / 0.9 sec 99.0% / 24.75 K Hz / 4.2 sec
Data Freshness (Max)	126 ms
DC Common Mode Rejection	> -120 dB
AC Common Mode Rejection	> -120 dB at 60 Hz
Maximum Operating Common Mode Voltage	250 V
Accuracy (% full scale)	±4 Hz or ±0.5% of the input frequency (whichever is greater)
Drift: Gain Temperature Coefficient	200 ppm / °C
Drift: Offset Temperature Coefficient	50 ppm / °C
Input Coupling	Single-ended AC (capacitor coupled)
Input Amplitude	
Sine wave	2.5 V to 24 V p-p
Square wave	0.5 V to 24 V p-p
Minimum Pulse Width	18 microseconds
Input Impedance (Inputs share the same reference point.)	50 K ohms AC coupled (-input to +input)
Pull-up Voltage	6 to 9 V
Pull-up Resistor	4.7 K ohms
Isolation	1500 V
Power Requirements	5 VDC (±0.15 V) at 190 mA
Operating Temperature	-20 °C to 70 °C
Storage Temperature	-40 °C to 85 °C
Humidity	5-95%, non-condensing
Wire size	22 to 14 AWG
Torque, hold-down screws	Not to exceed 1 in-lb (0.11 N-m)
Torque, connector screws	5.22 in-lb (0.59 N-m)
Agency Approvals	UL, FM, CE, RoHS, DFARS; UKCA
Warranty	Lifetime

SNAP-AIRATE-HFi

Input Range	2 Hz - 500 kHz at 1.0 s Data Freshness 20 Hz - 500 kHz at 0.1 s Data Freshness
Input Voltage Range	
Sine wave >= 2000 Hz	3.0 V to 48 V _{p-p}
Sine wave at 200 Hz	4.0 V to 48 V _{p-p}
Sine wave at 20 Hz	5.0 V to 48 V _{p-p}
Sine wave at 2 Hz	17 V to 48 V _{p-p}
Square wave	3.0 V to 48 V _{p-p}
Maximum survivable	110 V _{p-p}
Input Impedance	55 kOhms
Input Coupling	Single-ended AC
Pull-up Voltage	6 to 9 VDC
Pull-up Resistor	3.6 kOhm
Minimum Pulse Width	1 microsecond
Data Freshness*	100 ms at 20 Hz - 500 kHz 1.0 s at 2 Hz to 500 kHz
Resolution (Hz)	$f / (48,000,000 * \text{Data Freshness})$, where f is the current frequency measurement
Accuracy (at 1.0 s Data Freshness)	+/- 0.005% of input for input greater than 500 Hz +/- 0.005% of input plus an additional +/- 0.006 Hz for input less than 500 Hz
Maximum Operating Common Mode Voltage	250 V Continuous 1500 V Transient
DC Common Mode Rejection	> -120 dB
AC Common Mode Rejection	> -120 dB at 60 Hz
Isolation: Channel to Channel	250 V Continuous 1500 V Transient
Power Consumption	1.05 W (210 mA @ 5 V)
Ambient Temperature	
Operating	-20 to 70 °C
Storage	-40 to 85 °C
Humidity	5-95%, non-condensing
Torque, hold-down screws	Not to exceed 1 in-lb (0.11 N-m)
Torque, connector screws	5.22 in-lb (0.59 N-m)
Wire size range	22 to 14 AWG
Agency Approvals	CE, RoHS, DFARS; UKCA
Warranty	Lifetime

* User selectable. Default is 0.1 seconds.

SNAP-AIMV-4

Input Range	From -150 mV to +150 mV From -75 mV to +75m V
Over-Range Limits	From -165 to +165 mV (+/-150 mV range) From -82.5 to +82.5 mV (+/-75 mV range)
Resolution	6 microvolts (-150 mV to +150 mV) 3 microvolts (-75 mV to +75 mV)
Input Filtering	-3 dB @ 7 Hz
Input Response Time (% of span/delta V/delta time)	63.2%/95 mV/23 ms
Data Freshness (Max)	335 ms (+/- 150 mV) 668 ms (+/- 75 mV)
DC Common Mode Rejection	>-120 dB
AC Common Mode Rejection	>-120 dB @ 60 Hz
Maximum Survivable Input	±15 volts
Maximum Operating Common Mode Voltage	250 V
Accuracy at Full Scale	0.06% (90 microvolts) @ 150 mV 0.1% (75 microvolts) @ 75 mV
Drift: Gain Temperature Coefficient	3 microvolts / °C
Drift: Offset Temperature Coefficient	2 microvolts / °C
Isolation	1500 V
Power Requirements	5 VDC (±0.15) @ 170 mA
Input Resistance - Single Ended	100 Megohms (each channel)
Operating Temperature	-20 °C to 70 °C
Storage Temperature	-40 °C to 85 °C
Humidity	5-95%, non-condensing
Wire size	22 to 14 AWG
Torque, hold-down screws	Not to exceed 1 in-lb (0.11 N-m)
Torque, connector screws	5.22 in-lb (0.59 N-m)
Agency Approvals	UL, FM, CE, RoHS, DFARS; UKCA
Warranty	Lifetime

SNAP-AIRTD-1K, SNAP-AIRTD, and SNAP-AIRTD-10

	SNAP-AIRTD-1K	SNAP-AIRTD	SNAP-AIRTD-10
3-wire RTD input	1000 ohm platinum @ 0 °C $\alpha=0.00385$ 1000 ohm nickel @ 0 °C $\alpha=0.00618$ 1000 ohm nickel @ 70 °F $\alpha=0.00637$	100 ohm platinum; $\alpha=0.00385$ 100 ohm nickel, -60 to 250 °C 120 ohm nickel, -80 to 260 °C	10 ohm copper; $\alpha=0.00428$
Input Temperature Range	-200 °C to 850 °C (-328° to +1,582° F)	-200 °C to 850 °C (-328° to +1,582° F)	-180 °C to 260 °C (-292° to +500° F)
Input Range	0 to 4000 ohms	0 to 400 ohms	0 to 25 ohms
Over-Range Limit	to 4400 ohms	to 440 ohms	to 27.5 ohms
Resolution (average)	0.042 °C (0.16 ohms)	0.042 °C (0.016 ohms)	0.026 °C (0.001 ohms)
Input Filtering	-3 dB @ 0.1 Hz	-3 dB @ 0.1 Hz	-3 dB @ 100 Hz
Data Freshness (Max)	100 ms	100 ms	168 ms
Lead Compensation	Automatic when used with SNAP brains	Automatic when used with SNAP brains	Automatic when used with SNAP PAC brains
DC Common Mode Rejection	>-120 dB	>-120 dB	>-120 dB
AC Common Mode Rejection	>-120 dB at 60 Hz	>-120 dB at 60 Hz	>-120 dB at 60 Hz
Excitation (typical)	0.256 mA constant current	1.25 mA constant current	5.4 mA constant current
Maximum Lead Resistance	40 ohms single wire (all leads to be equal resistance)	40 ohms single wire (all leads to be equal resistance)	15 ohms single wire (all leads to be equal resistance)
Maximum Fault Voltage at Input (between any 2 field wires)	±15 V	±15 V	±15 V
Maximum Operating Common Mode Voltage	250 V	250 V	250 V
Accuracy			
From factory	0.8 °C	0.8 °C	0.6 °C
After setting gain and offset	0.6 °C	0.6 °C	0.5 °C
Isolation	1500 V	1500 V	1500 V
Power Requirements	5.00 to 5.20 VDC @ 190 mA	5.00 to 5.20 VDC @ 190 mA	5.00 to 5.20 VDC @ 190 mA
Operating Temperature	-20 °C to 70 °C	-20 °C to 70 °C	-20 °C to 70 °C
Storage Temperature	-40 °C to 85 °C	-40 °C to 85 °C	-40 °C to 85 °C
Wire size	22 to 14 AWG	22 to 14 AWG	22 to 14 AWG
Humidity	5-95%, non-condensing	5-95%, non-condensing	5-95%, non-condensing
Torque, hold-down screws	Not to exceed 1 in-lb (0.11 N-m)	Not to exceed 1 in-lb (0.11 N-m)	Not to exceed 1 in-lb (0.11 N-m)
Torque, connector screws	5.22 in-lb (0.59 N-m)	5.22 in-lb (0.59 N-m)	5.22 in-lb (0.59 N-m)
Agency Approvals	CE, RoHS, DFARS; UKCA	UL, FM, CE, RoHS, DFARS; UKCA	CE, RoHS, DFARS; UKCA
Warranty	Lifetime	Lifetime	Lifetime

SNAP-AIRTD-8U

SNAP-AIRTD-8U			
3-wire RTD input and maximum temperature table range (actual range depends on your probe)	1000 ohm platinum @ 0 °C $\alpha = 0.00385$ Range: -200 to 850 °C (-328 to 1,582 °F)	100 ohm platinum @ 0 °C $\alpha = 0.00385$ Range: -200 °C to 850 °C (-328 to 1,582 °F)	10 ohm copper @ 25 °C $\alpha = 0.00427$ Range: -60 to 355 °C (-76 to 671 °F)
	1000 ohm nickel @ 0 °C $\alpha = 0.00618$ Range: -60 to 170 °C (-76 to 356 °F)	100 ohm nickel @ 0 °C $\alpha = 0.00618$ Range: -60 to 250 °C (-76 to 482 °F)	
	1000 ohm nickel @ 70 °F $\alpha = 0.00637$ Range: -46 to 148.9 °C (-50 to 300 °F)	120 ohm nickel @ 0 °C $\alpha = 0.00672$ Range: -80 to 260 °C (-112 to 500 °F)	
Input Range	0 to 4000 ohms	0 to 400 ohms	0 to 40 ohms
Accuracy From factory After setting gain and offset	0.8 °C (Pt); 0.6 °C (Ni) 0.6 °C (Pt); 0.4 °C (Ni)	0.8 °C (Pt); 0.6 °C (Ni) 0.6 °C (Pt); 0.4 °C (Ni)	1.7 °C 1.2 °C
Excitation Current	0.325 mA	2 mA	4.28 mA
Over-Range Limit	10% overrange for all measurements in ohms		
Resolution In Ohms In RTD Temperature	The greater of: (Ohms Range / 100,000) or 1 milliohm Better than or equal to 0.05 °C (0.09 °F)		
Input Filtering Front end filtering DSP Notch filter	-15 dB @ 50 Hz, -20 dB @ 60 Hz 20 Hz (-3 DdB = 5.24 Hz)		
Data Freshness (Max)	1.2 s		
Auto-range Settle Time Step change from 10 to 8000 Step change from 8000 to 10	1.2 s to the next higher or lower range <= 10 s ranging up (channel may show overrange until settled) <= 10 s ranging down (channel will give a reading while settling)		
Total Lead Resistance	200 ohms maximum		
DC Common Mode Rejection	>-120 dB		
AC Common Mode Rejection	>-120 dB at 60 Hz		
Maximum Survivable Fault Voltage at Input (between any 2 field wires)	±8 V		
Maximum Operating Common Mode Voltage	250 V field terminal to logic connector		
Isolation	1500 V field side to logic side		
Power Requirements	5.00 to 5.20 VDC @ 135 mA		
Operating Temperature	-20 °C to 70 °C		
Storage Temperature	-40 °C to 85 °C		
Humidity	5-95%, non-condensing		
Maximum wire size	20 AWG		
Torque, hold-down screws	Not to exceed 1 in-lb (0.11 N-m)		
Agency Approvals	UL, CE, RoHS, DFARS; UKCA		
Warranty	Lifetime		

SNAP-AIR400K-8

Input Ranges	<ul style="list-style-type: none"> • 400 K, 200 K, 100 K, 50 K, 40 K, 20 K, 10 K, 5 K, 4 K, 2 K, 1 K, 500 Ohms, or Autorange • Predefined or custom curve 																																																											
Resolution	<u>Resolution</u>	<u>Range</u>	<u>Resolution</u>	<u>Range</u>	<u>Resolution</u>	<u>Range</u>																																																						
	16 Ohm	0 to 400 kOhms	1.6 Ohm	0 to 40 kOhms	0.16 Ohm	0 to 4 kOhms																																																						
	8 Ohm	0 to 200 kOhms	0.8 Ohm	0 to 20 kOhms	0.08 Ohm	0 to 2 kOhms																																																						
	4 Ohm	0 to 100 kOhms	0.4 Ohm	0 to 10 kOhms	0.04 Ohm	0 to 1 kOhms																																																						
	2 Ohm	0 to 50 kOhms	0.2 Ohm	0 to 5 kOhms	0.02 Ohm	0 to 500 Ohms																																																						
Accuracy (Ohms @ Range) 0.1% Reading + 2x Range Resolution + 1 Ohm	400 Ohms @ 400 K 200 Ohms @ 200 K 100 Ohms @ 100 K 0 Ohms @ 50 K		40 Ohms @ 40 K 20 Ohms @ 20 K 10 Ohms @ 10 K 5 Ohms @ 5 K		4 Ohms @ 4 K 2 Ohms @ 2 K 1 Ohms @ 1 K 0.5 Ohms @ 500																																																							
Data Freshness	1.61 seconds maximum																																																											
DSP Notch Filter	20 Hz (-3DB = 5.24 Hz)																																																											
Excitation Current Nominal (Range & Load Watts Dissipation)	9uA (50 K–4.1 uW), (100 K–8.1 uW), (200 K–16 uW), (400 K–32 uW) 90uA (5 K–40 uW), (10 K–81 uW), (20 K–160 uW), (40 K–320 uW) 200uA (500 K–20 uW), (1 K–40 uW), (2 K–80 uW), (4 K–160 uW)																																																											
Autorange Step Time	1.6 seconds to next higher or lower range >= 10 seconds for a 500 Ohms to 400 K Ohms step change																																																											
Autorange Ohms Hysteresis	<table border="1"> <thead> <tr> <th colspan="6">Ranges</th> </tr> <tr> <th>Ohms</th> <th>Open ></th> <th>440K</th> <th>Ohms</th> <th>Open ></th> <th>440K</th> </tr> </thead> <tbody> <tr> <td>20K</td> <td>between</td> <td>200K & 400K</td> <td>1.9K</td> <td>between</td> <td>4K & 5K</td> </tr> <tr> <td>10K</td> <td>between</td> <td>100K & 200K</td> <td>200</td> <td>between</td> <td>2K & 4K</td> </tr> <tr> <td>5K</td> <td>between</td> <td>50K & 100K</td> <td>100</td> <td>between</td> <td>1K & 2K</td> </tr> <tr> <td>19K</td> <td>between</td> <td>40K & 50K</td> <td>50</td> <td>between</td> <td>500 & 1K</td> </tr> <tr> <td>2K</td> <td>between</td> <td>20K & 40K</td> <td></td> <td></td> <td></td> </tr> <tr> <td>1K</td> <td>between</td> <td>10K & 20K</td> <td></td> <td></td> <td></td> </tr> <tr> <td>500</td> <td>between</td> <td>5K & 10K</td> <td></td> <td></td> <td></td> </tr> </tbody> </table>						Ranges						Ohms	Open >	440K	Ohms	Open >	440K	20K	between	200K & 400K	1.9K	between	4K & 5K	10K	between	100K & 200K	200	between	2K & 4K	5K	between	50K & 100K	100	between	1K & 2K	19K	between	40K & 50K	50	between	500 & 1K	2K	between	20K & 40K				1K	between	10K & 20K				500	between	5K & 10K			
Ranges																																																												
Ohms	Open >	440K	Ohms	Open >	440K																																																							
20K	between	200K & 400K	1.9K	between	4K & 5K																																																							
10K	between	100K & 200K	200	between	2K & 4K																																																							
5K	between	50K & 100K	100	between	1K & 2K																																																							
19K	between	40K & 50K	50	between	500 & 1K																																																							
2K	between	20K & 40K																																																										
1K	between	10K & 20K																																																										
500	between	5K & 10K																																																										
Predefine Curve	2252 curve, 3 K curve, 10 K type 3 curve, 10 K type 2 curve (by Automation Components, Inc.)																																																											
DC Common Mode Rejection	>-120 dB																																																											
AC Common Mode Rejection	>-120 dB @ 60 Hz																																																											
Open Resistor Indicator	Channel resistance = 999,999.999 Ohms																																																											
PAC Control Reads	temperature reading or -32768 Ohms if over or under range																																																											
Maximum Operating Common Mode Voltage (Field Term to Logic Connector)	500 VDC or peak VAC																																																											
Drift																																																												
Gain Tempco	30 PPM / °C																																																											
Offset Tempco	15 PPM / °C																																																											
Power Requirements	5 VDC (±0.15) @ 190 mA																																																											
Operating Temperature	-20 °C to 70 °C																																																											
Storage Temperature	-40 °C to 85 °C																																																											
Torque, hold-down screws	Not to exceed 1 in-lb (0.11 N-m)																																																											
Humidity	5-95%, non-condensing																																																											
Torque, connector screws	5.22 in-lb (0.59 N-m)																																																											
Agency Approvals	UL, CE; UKCA																																																											
Warranty	Lifetime																																																											

SNAP-AIR40K-4

Input Range	0 to 40,000 Ohms 0 to 20,000 Ohms 0 to 10,000 Ohms 0 to 5,000 Ohms
Maximum Over-Range	44 K (40 K Ohms range) 22 K (20 K Ohms range) 11 K (10 K Ohms range) 5.5 K (5 K Ohms range)
Resolution	1.6 Ohm @ 40 K Ohms 0.8 Ohm @ 20 K Ohms 0.4 Ohm @ 10 K Ohms 0.2 Ohm @ 5 K Ohms
Input Filtering	-3 dB @ 3.2 Hz
Data Freshness (Max)	100 (40 K Ohms) 200 (20 K Ohms) 400 (10 K Ohms) 800 (5 K Ohms)
DC Common Mode Rejection	>-120 dB
AC Common Mode Rejection	>-120 dB @ 60 Hz
Maximum Operating Common Mode Voltage	250 V
Accuracy	0.1% ± 40 Ohms @ 40 K Ohms 0.1% ± 20 Ohms @ 20 K Ohms 0.1% ± 10 Ohms @ 10 K Ohms 0.1% ± 5 Ohms @ 5 K Ohms
DRIFT: Gain Temperature Coefficient	30 PPM/ °C
DRIFT: Offset Temperature Coefficient	15 PPM/ °C
Isolation	1500 V
Power Requirements	5 VDC (±0.15) @ 190 mA
Operating Temperature	-20 °C to 70 °C
Storage Temperature	-40 °C to 85 °C
Humidity	5-95%, non-condensing
Wire size	22 to 14 AWG
Torque, hold-down screws	Not to exceed 1 in-lb (0.11 N-m)
Torque, connector screws	5.22 in-lb (0.59 N-m)
Agency Approvals	UL, FM, CE, RoHS, DFARS
Warranty	Lifetime

SNAP-AITM

Input Range	-150 mV to +150 mV -75 mV to +75 mV
Over-Range Limits	-165 to +165 mV (+/-150 mV range) -82.5 to +82.5 mV (+/-75 mV range)
Resolution	6 microvolts from -150 to +150 mV 3 microvolts from -75 to +75 mV
Cold Junction Temperature Compensation	Automatic when used with SNAP I/O processors
Input Filtering	-3 dB @ 7 Hz
Input Response Time (% of span/delta V/delta time)	63.2%/95 mV/23 mS
Data Freshness (Max)	167 ms (+/-150 mV) 334 ms (+/-75 mV)
DC Common Mode Rejection	>-120 dB
AC Common Mode Rejection	>-120 dB @ 60 Hz
Maximum Survivable Input	±15 volts
Maximum Operating Common Mode Voltage	250 V
Accuracy at Full Scale	0.06% (90 microvolts) @ 150 mV 0.1% (75 microvolts) @ 75 mV
Drift: Gain Temperature Coefficient	5 microvolts / °C
Drift: Offset Temperature Coefficient	2 microvolts / °C
Thermocouple Accuracy [°C]	
From factory	± 2.0 (E, J, and K)
After user gain and offset commands	± 0.8
Isolation	1500 V
Power Requirements	5 VDC (±0.15) @ 170 mA
Input Resistance	100 Megohms (each channel)
Ambient Temperature:	
Operating	-20 °C to 70 °C
Storage	-40 °C to 85 °C
Humidity	5-95%, non-condensing
Torque, hold-down screws	Not to exceed 1 in-lb (0.11 N-m)
Torque, connector screws	3 in-lb (0.34 N-m)
Agency Approvals	FM, CE, RoHS, DFARS; UKCA
Warranty	Lifetime

SNAP-AITM-2

Input Range	-50 mV to +50 mVDC -25 mV to +25 mVDC		
Over-range Limits	-55 to +55 mV (+/-50 mV range) -27.5 to +27.5 mV (+/-25 mV range)		
Resolution	2 microvolts from -50 mV to +50 mV 1 microvolts from -25 mV to +25 mV		
Cold Junction Temperature Compensation	Automatic when used with SNAP brains		
Input Filtering	-3 dB @ 2.4 Hz		
Input Response Time (% of span/delta V/delta time)	63.2%/31.5 mV/66 ms		
Data Freshness (Max)	167 ms (+/- 50 mV) 334 ms (+/- 25 mV)		
DC Common Mode Rejection	>-120 dB		
AC Common Mode Rejection	>-120 dB @ 60 Hz		
Maximum Survivable Input	±15 volts		
Maximum Operating Common Mode Voltage	250 V		
Accuracy at Full Scale	0.1% (50 microvolts) @ 50 mV 0.2% (50 microvolts) @ 25 mV		
Drift: Gain Temperature Coefficient	5 microvolts / °C		
Drift: Offset Temperature Coefficient	2 microvolts / °C		
Thermocouple Accuracy [°C]	B, R, S	C, D, G	T, N
From factory	±5	±4	±3
After user gain and offset commands	±3	±2	±2
Isolation	1500 V		
Power Requirements	5 VDC (±0.15) @ 170 mA		
Input Resistance	100 Megohms (each channel)		
Ambient Temperature:			
Operating	-20 °C to 70 °C		
Storage	-40 °C to 85 °C		
Humidity	5-95%, non-condensing		
Agency Approvals	FM, CE, RoHS, DFARS; UKCA		
Torque, hold-down screws	Not to exceed 1 in-lb (0.11 N-m)		
Torque, connector screws	3 in-lb (0.34 N-m)		
Warranty	Lifetime		

SNAP-AIV-i

Input Range	From -10 volts to +10 volts From -5 volts to +5 volts
Maximum Over Range	$\pm 10\%$ (= ± 27500 counts)
Resolution	0.4 mV when configured -10 volts to +10 volts 0.2 mV when configured -5 volts to +5 volts
Input Filtering	-3 dB @ 64 Hz
Input Response Time (% of span/ DV / Dt)	63.2% / 6.7 V / 10 mS
Data Freshness	11 ms for +/- 10 V 18 ms for +/- 5 V
DC Common Mode Rejection	>-120 dB
AC Common Mode Rejection	>-120 dB @ 60 Hz
Maximum Survivable Input	220 VAC or 300 VDC
Maximum Operating Common Mode Voltage	250 V
Accuracy	0.05%, 5 mV @ 10 VDC 2.5 mV @ 5 VDC
Gain Temperature Coefficient	30 PPM/ °C
Offset Temperature Coefficient	15 PPM/ °C
Isolation: Optical	4000 V
Isolation: Transformer	1500 V
Isolation: Channel to Channel	250 V continuous (1500 V transient)
Power Requirements	5 VDC (± 0.15) @ 200 mA
Input Resistance	1 megohms (each channel)
Ambient Temperature:	
Operating	-20 °C to 70 °C
Storage	-40 °C to 85 °C
Humidity	5-95%, non-condensing
Torque, hold-down screws	Not to exceed 1 in-lb (0.11 N-m)
Torque, connector screws	5.22 in-lb (0.59 N-m)
Wire size range	22 to 14 AWG
Agency Approvals	UL, CE, FM, RoHS, DFARS; UKCA
Warranty	Lifetime

SNAP-AITM-i

Input Range	From -150 mV to +150 mV From -75 mV to +75 mV
Maximum Over Range	± 10% (= ± 27500 counts)
Resolution	6 µV from -150 mV to +150 mV 3 µV from -75 mV to +75 mV
Cold Junction Temperature Compensation	Automatic when used with SNAP brains
Input Filtering	-3 dB @ 7 Hz
Input Response Time (% of span/delta V/delta time)	63.2%/95 mV/23 mS
Data Freshness	65 ms for +/- 150 mV 130 ms for +/- 75 mV 130 ms for E-, J-, and K-type thermocouples
DC Common Mode Rejection	>-120 dB
AC Common Mode Rejection	>-120 dB @ 60 Hz
Maximum Survivable Input	±15 volts
Maximum Operating Common Mode Voltage	250 V
Accuracy	0.06% (90 µV) @ 150 mV (full scale) 0.1% (75 µV) @ 75 mV (full scale)
Drift: Gain Temperature Coefficient	5 µV / °C
Drift: Offset Temperature Coefficient	2 µV / °C
Thermocouple Accuracy [°C]	
From factory	± 2.0 (E, J, and K)
After user gain and offset commands	± 0.8
Isolation: Optical	4000 V
Isolation: Transformer	1500 V
Isolation: Channel to Channel	250 V continuous (1500 V transient)
Power Requirements	5 VDC (±0.15) @ 200 mA
Input Resistance	100 megohms (each channel)
Ambient Temperature:	
Operating	-20 °C to 70 °C
Storage	-40 °C to 85 °C
Humidity	5-95%, non-condensing
Torque, hold-down screws	Not to exceed 1 in-lb (0.11 N-m)
Torque, connector screws	3 in-lb (0.34 N-m)
Wire size range	22 to 14 AWG
Agency Approvals	CE, FM, RoHS, DFARS; UKCA
Warranty	Lifetime

SNAP-AITM-8

Input Range	-75 mV to +75 mV -50 mV to +50 mV -25 mV to +25 mV			
Over-Range Limits	-82.5 to +82.5 mV (+/-75 mV range) -55 to +55 mV (+/-50 mV range) -27.5 to +27.5 mV (+/-25 mV range)			
Resolution	3 microvolts from -75 mV to +75 mV 2 microvolts from -50 mV to +50 mV 1 microvolts from -25 mV to +25 mV			
Cold Junction Temperature Compensation	Automatic when used with SNAP I/O processors			
Input Filtering	-3 dB @ 5 Hz			
Data Freshness (Max)	2.25 s			
DC Common Mode Rejection	>-120 dB			
AC Common Mode Rejection	>-120 dB @ 60 Hz			
Maximum Survivable Input	±15 volts			
Max Operating Common Mode Voltage	250 V			
Accuracy at Full Scale	0.1% (75 microvolts) @ 75 mV 0.1% (50 microvolts) @ 50 mV 0.2% (50 microvolts) @ 25 mV			
Drift: Gain Temperature Coefficient	5 microvolts / °C			
Drift: Offset Temperature Coefficient	2 microvolts / °C			
Thermocouple Accuracy [°C]	E, J, K	B, R, S	C, D, G	T, N
From factory	±2.0	±5	±4	±3
After user gain and offset commands	±0.5	±3	±2	±2
Isolation	1500 V			
Power Requirements	5 VDC (±0.15) @ 200 mA			
Input Resistance	100 Megohms (each channel)			
Ambient Temperature:	Operating -20 °C to 70 °C Storage -40 °C to 85 °C			
Humidity	5-95%, non-condensing			
Torque, hold-down screws	Not to exceed 1 in-lb (0.11 N-m)			
Torque, connector screws	3 in-lb (0.34 N-m)			
Agency Approvals	SNAP-AITM-8: UL, CE, RoHS, DFARS; UKCA SNAP-AITM-8-FM: FM, CE, RoHS, DFARS; UKCA			
Warranty	Lifetime			

SNAP-AIV2-i

Input Range	From -100 volts to +100 volts From -50 volts to +50 volts
Maximum Over Range	± 10% (= ± 27500 counts)
Resolution	4.0 mV when configured -100 volts to +100 volts 2.0 mV when configured -50 volts to +50 volts
Input Filtering	-3 dB @ 64 Hz
Input Response Time (% of span/ DV / Dt)	63.2% / 6.7 V / 10 ms
Data Freshness	11 ms for +/- 100 V 18 ms for +/- 50 V
DC Common Mode Rejection	>-120 dB
AC Common Mode Rejection	>-120 dB @ 60 Hz
Maximum Survivable Input	220 VAC or 300 VDC
Maximum Operating Common Mode Voltage	250 V
Accuracy	0.05%, 50 mV @ 100 VDC 25 mV @ 50 VDC
Gain Temperature Coefficient	30 PPM/ °C
Offset Temperature Coefficient	15 PPM/ °C
Isolation: Optical	4000 V
Isolation: Transformer	1500 V
Isolation: Channel to Channel	250 V continuous (1500 V transient)
Power Requirements	5 VDC (±0.15) @ 200 mA
Input Resistance	1 megohms (each channel)
Ambient Temperature: Operating Storage	-20 °C to 70 °C -40 °C to 85 °C
Humidity	5-95%, non-condensing
Torque, hold-down screws	Not to exceed 1 in-lb (0.11 N-m)
Torque, connector screws	5.22 in-lb (0.59 N-m)
Wire size range	22 to 14 AWG
Agency Approvals	CE, RoHS, DFARS; UKCA
Warranty	Lifetime

SNAP-AIV and SNAP-AIV-4

Input Range	From -10 volts to +10 volts From -5 volts to +5 volts
Over-Range Limits	From -11 to +11 volts (+/-10 V range) From -5.5 to +5.5 volts (+/-5 V range)
Resolution	0.4 mV when configured -10 to +10 volts 0.2 mV when configured -5 to +5 volts
Input Filtering	-3 dB @ 64 Hz
Input Response Time (% of span/ delta V / delta t)	63.2% / 6.7 V / 10 ms
Data Freshness (Max)	11.5 ms (2-channel, +/- 10 VDC) 23 ms (2-channel, +/- 5 VDC) 23 ms (4-channel, +/- 10 VDC) 46 ms (4-channel, +/- 5 VDC)
DC Common Mode Rejection	>-120 dB
AC Common Mode Rejection	>-120 dB @ 60 Hz
Maximum Survivable Input	220 VAC or 300 VDC
Maximum Operating Common Mode Voltage	250 V
Accuracy	0.05%, 5 mV @ 10 VDC 2.5 mV @ 5 VDC
Gain Temperature Coefficient	30 PPM/ °C
Offset Temperature Coefficient	15 PPM/ °C
Isolation	1500 V
Power Requirements	5 VDC (±0.15) @ 170 mA
Input Resistance	1 M ohms (each channel; both channels share the same reference point)
Ambient Temperature: Operating Storage	-20 °C to 70 °C -40 °C to 85 °C
Humidity	5-95%, non-condensing
Wire size	22 to 14 AWG
Torque, hold-down screws	Not to exceed 1 in-lb (0.11 N-m)
Torque, connector screws	5.22 in-lb (0.59 N-m)
Agency Approvals	UL, FM, CE, RoHS, DFARS; UKCA NEBS (SNAP-AIV only)
Warranty	Lifetime

SNAP-AIV-8

Input Range	-10 volts to +10 volts -5 volts to +5 volts
Over-Range Limits	-11 to +11 volts (+/-10 V range) -5.5 to +5.5 volts (+/-5 V range)
Resolution	0.4 mV when configured -10 to +10 V 0.2 mV when configured -5 to +5 V
Input Filtering	-3 dB @ 64 Hz
Data Freshness (Max)	0.28 seconds
DC Common Mode Rejection	>-120 dB
AC Common Mode Rejection	>-120 dB @ 60 Hz
Maximum Survivable Input	220 VAC or 300 VDC
Maximum Operating Common Mode Voltage	250 V
Accuracy	0.05%, 5 mV @ 10 VDC 2.5 mV @ 5 VDC
Gain Temperature Coefficient	30 PPM/ °C
Offset Temperature Coefficient	15 PPM/ °C
Isolation	1500 V
Power Requirements	5 VDC (±0.15) @ 170 mA
Input Resistance	1 M ohms (all channels share the same reference point)
Ambient Temperature: Operating Storage	-20 °C to 70 °C -40 °C to 85 °C
Humidity	5-95%, non-condensing
Torque, hold-down screws	Not to exceed 1 in-lb (0.11 N-m)
Torque, connector screws	1.7 in-lb (0.19 N-m)
Agency Approvals	CE, RoHS, DFARS
Warranty	Lifetime

SNAP-AIV-32

Input Range	-10 volts to +10 volts -5 volts to +5 volts
Over-Range Limits	-11 to +11 volts (+/-10 V range) -5.5 to +5.5 volts (+/-5 V range)
Resolution	0.4 mV when configured -10 volts to +10 volts 0.2 mV when configured -5 volts to +5 volts
Input Filtering	-3 dB @ 31 Hz
Data Freshness (Max)	1.1 s
DC Common Mode Rejection	>-120 dB
AC Common Mode Rejection	>-120 dB @ 60 Hz
Maximum Survivable Input	220 VAC or 300 VDC
Maximum Operating Common Mode Voltage	250 V
Accuracy	0.05%, 5 mV @ 10 VDC 2.5 mV @ 5 VDC
Gain Temperature Coefficient	30 PPM/ °C
Offset Temperature Coefficient	15 PPM/ °C
Isolation	1500 V
Power Requirements	5 VDC (±0.15) @ 150 mA
Input Resistance	1 M ohms (each channel; all channels share the same reference point)
Ambient Temperature: Operating Storage	-20 °C to 70 °C -40 °C to 85 °C
Humidity	5-95%, non-condensing
Torque, hold-down screws	Not to exceed 1 in-lb (0.11 N-m)
Torque, connector screws	5.22 in-lb (0.59 N-m)
Agency Approvals	SNAP-AIV-32: UL, CE, RoHS, DFARS; UKCA SNAP-AIV-32-FM: FM, CE, RoHS, DFARS; UKCA
Warranty	Lifetime

SNAP-AIVRMS

Input Range	0 to 250 V RMS AC/DC
Input Over-Range	To 275 V
Input Resistance	1 M ohms
Accuracy	±0.2 V and ±0.2% reading
Resolution	10 mV
DC Reversal	± 0.4 V (.16%)
Input Response Time (Step Change)	5% (12.5 V) in 100 mS 63.2% (158 V) in 200 mS 99% (248 V) in 1200 mS
Data Freshness (Max)	32.3 ms
DC Common Mode Rejection	>-120 dB
AC Common Mode Rejection	>-120 dB @ 60 Hz
Maximum Operating Common Mode Voltage	250 V
Isolation	1500 V
Power Requirements	5 VDC (±0.15 V) at 170 mA
Operating Temperature	-20 °C to 70 °C
Storage Temperature	-40 °C to 85 °C
Humidity	5-95%, non-condensing
Wire size	22 to 14 AWG
Torque, hold-down screws	Not to exceed 1 in-lb (0.11 N-m)
Torque, connector screws	5.22 in-lb (0.59 N-m)
Agency Approvals	UL, FM, CE, RoHS, DFARS; UKCA
Warranty	Lifetime

SNAP-AIVRMS-i

Input Range	0 to 250 V RMS AC/DC
Input Over Range	To 275 V
Input Resistance	1 megohms
Accuracy	±0.2 V and ±0.2% reading
Resolution	10 mV
DC Reversal	± 0.2 V (0.08%)
Input Response Time (Step Change)	63.2% (158 V) in 50 ms 99% (248 V) in 75 ms
Data Freshness	25 ms
DC Common Mode Rejection	>-120 dB
AC Common Mode Rejection	>-120 dB @ 60 Hz
Maximum Operating Voltage Between Channels Common Mode Voltage	250 V 250 V
Isolation: Optical	4000 V
Isolation: Transformer	1500 V
Isolation: Channel to Channel	250 V continuous (1500 V transient)
Power Requirements	5 VDC (±0.15 V) at 200 mA
Ambient Temperature: Operating Storage	-20 °C to 70 °C -40 °C to 85 °C
Humidity	5-95%, non-condensing
Torque, hold-down screws	Not to exceed 1 in-lb (0.11 N-m)
Torque, connector screws	5.22 in-lb (0.59 N-m)
Wire size range	22 to 14 AWG
Agency Approvals	CE, RoHS, DFARS FM (SNAP-AIVRMS-i-FM only)
Warranty	Lifetime

ANALOG OUTPUT MODULE SPECIFICATIONS

SNAP-AOA-3

Input	12-bit serial data			
Output	4 to 20 mA (floating)			
Span	16 mA			
Resolution	3.9 microamps			
Response Time (% of span/delta I/ delta time)	99.9%/15.98 mA/3 mS			
DC Common Mode Rejection	>-120 dB			
AC Common Mode Rejection	>-120 dB @ 60 Hz			
Maximum Operating Common Mode Voltage	250 V			
Common Mode Resistance	>1000 M W			
Accuracy	0.1% of span			
Gain Temperature Coefficient	50 PPM/ °C			
Offset Temperature Coefficient	20 PPM/ °C			
Module Power Requirements	5 Volts DC (±0.15) @ 140 mA			
Loop Power Requirements	10 Volts DC (min) to 32 Volts DC (max)			
Max. Loop Resistance (Ohms) @ Loop Supply	250 10V	350 12V	950 24V	1350 32V
Max. Loop Resistance formula	$\frac{(\text{Loop Voltage} - 5)}{0.02}$			
Ambient Temperature: Operating	-20 °C to 70 °C			
Ambient Temperature: Storage	-40 °C to 85 °C			
Humidity	5-95%, non-condensing			
Torque, hold-down screws	Not to exceed 1 in-lb (0.11 N-m)			
Torque, connector screws	5.22 in-lb (0.59 N-m)			
Wire size range	22 to 14 AWG			
Agency Approvals	UL, CE, RoHS, DFARS; UKCA			
Warranty	Lifetime			

SNAP-AOA-23

Input	12-bit serial data (each channel)				
Outputs	4 to 20 mA (each channel)				
Span	16 mA				
Resolution	3.9 microamps				
Response Time (% of span/delta I/ delta time)	99.9%/15.98 mA/3 mS				
DC Common Mode Rejection	>-120 dB				
AC Common Mode Rejection	>-120 dB @ 60 Hz				
Maximum Operating Common Mode Voltage	250 V				
Common Mode Resistance	>1000 Megohms				
Accuracy	0.1% of Span				
Gain Temperature Coefficient	50 PPM/°C				
Offset Temperature Coefficient	20 PPM/°C				
Module Power Requirements	5 Volts DC (±0.15) @ 150 mA				
Loop Power Requirements	8 VDC (min) to 32 Volts DC (max)				
Max. Loop Resistance (Ohms) @ Loop Supply	250 8V	450 12V	650 15V	1050 24V	1450 32V
Max. Loop Resistance formula	$\frac{(\text{Loop Voltage} - 3)}{0.02}$				
Ambient Temperature: Operating	-20 °C to 70 °C				
Ambient Temperature: Storage	-40 °C to 85 °C				
Humidity	5-95%, non-condensing				
Torque, connector screws	5.22 in-lb (0.59 N-m)				
Wire size range	22 to 14 AWG				
Agency Approvals	UL, CE, FM, RoHS, DFARS; UKCA, NEBS				
Warranty	Lifetime				

SNAP-AOA-23-iSRC and SNAP-AOA-23-iSRC-FM

Input	12-bit serial data (each channel)
Outputs	4 to 20 mA (each channel)
Span	16 mA
Resolution	3.9 microamps
Response Time (% of span/delta I/ delta time)	99.9%/15.98 mA/3 mS
DC Common Mode Rejection	>-120 dB
AC Common Mode Rejection	>-120 dB @ 60 Hz
Maximum Operating Common Mode Voltage	250 V
Common Mode Resistance	>1000 Megohms
Accuracy	0.1% of Span
Gain Temperature Coefficient	50 PPM/°C
Offset Temperature Coefficient	20 PPM/°C
Max. Loop Resistance @ Loop Supply	950 Ohms
Ambient Temperature: Operating Storage	-20 °C to 70 °C -40 °C to 85 °C
Humidity	5-95%, non-condensing
Isolation: Optical	4000 V
Isolation: Transformer	1500 V
Isolation: Channel to Channel	250 V continuous (1500 V transient)
Power Requirements	5 Volts DC (± 0.15) @ 200 mA
Power Requirements - Loop Power (Input)	From separate field connector; 24 VDC nominal (70 mA max) @ 24 V input, both loops @ 20 mA), 30 VDC maximum
Loop Power (Output)	24 VDC (± 1.5 V) @ 20 mA Open loop: 30 V maximum Shorted loop: 24 mA nominal
LED on top of module	Indicates that there is power to the 24v source supply 2-pin connector
Agency Approvals	CE, RoHS, DFARS, UKCA SNAP-AOA-23-iSRC-FM: FM, ATEX
Torque, hold-down screws	Not to exceed 1 in-lb (0.11 N-m)
Torque, connector screws	5.22 in-lb (0.59 N-m)
Wire size range	22 to 14 AWG
Warranty	Lifetime

ANALOG OUTPUT MODULE SPECIFICATIONS

SNAP-AOA-28

Input	12-bit serial data (each channel)				
Outputs	0 to 20 mA (each channel)				
Span	20 mA				
Resolution	4.9 microamps				
Response Time (% of span/delta I/ delta time)	99.9%/15.98 mA/3 mS				
DC Common Mode Rejection	>-120 dB				
AC Common Mode Rejection	>-120 dB @ 60 Hz				
Maximum Operating Common Mode Voltage	250 V				
Common Mode Resistance	>1000 Megohms				
Accuracy	0.1% of Span				
Gain Temperature Coefficient	50 PPM/°C				
Offset Temperature Coefficient	20 PPM/°C				
Module Power Requirements	5 Volts DC (±0.15) @ 150 mA				
Loop Power Requirements	8 Volts DC (min) to 32 Volts DC (max)				
Max. Loop Resistance (Ohms) @ Loop Supply	250 8V	450 8V	650 12V	1050 24V	1450 32V
Max. Loop Resistance formula	$\frac{(\text{Loop Voltage} - 5)}{0.02}$				
Ambient Temperature:					
Operating	-20 °C to 70 °C				
Storage	-40 °C to 85 °C				
Humidity	5-95%, non-condensing				
Torque, connector screws	5.22 in-lb (0.59 N-m)				
Wire size range	22 to 14 AWG				
Agency Approvals	UL, CE, ATEX, FM, RoHS, DFARS; UKCA				
Warranty	Lifetime				

SNAP-AOD-29

Input	12-bit serial data (each channel)
Switched Output at 45 °C Ambient at 70 °C Ambient	5 to 60 Volts DC 0.5 A 0.2 A
TPO Resolution	12-bit. Each bit = Period/4095 1 millisecond/bit default
Period Range	0.251 sec. to 64.25 sec. (0.251 sec for Ethernet-based I/O units) 0.251 seconds module default
Period Accuracy	± 0.5%
Period Resolution	.251 second
Inhibit Inputs On	4.0 Volts DC at 1.0 mA (32 Volts DC max.)
Off	1.0 Volt DC
Maximum Operating Com- mon Mode Voltage	250 V
Common Mode Resistance	>1,000 Megohms
Timebase Temperature Coef- ficient	50 PPM/°C
Power Requirements	5 Volts DC (±0.15) @ 150 mA
Ambient Temperature: Operating Storage	-20 °C to 70 °C -40 °C to 85 °C
Humidity	5-95%, non-condensing
Torque, hold-down screws	Not to exceed 1 in-lb (0.11 N-m)
Torque, connector screws	5.22 in-lb (0.59 N-m)
Wire size range	22 to 14 AWG
Agency Approvals	UL, FM, CE, RoHS, DFARS; UKCA
Warranty	Lifetime

SNAP-AOD-29-HFi

Switched Output	2.5 to 24 VDC at 100 mA supplied externally
Maximum Survivable Switch Voltage	60 VDC
Peak Current	1.0 A (t < 10 milliseconds)
Period Range	0.00001 sec to 64.25 sec
Percent Range	0-100%
Period Resolution	20.8 nanoseconds
Percent Resolution	0.024% (12-bit)
Period Accuracy	+/- 0.005% of period
Pull-up Voltage	4.5 to 5.0 VDC
Pull-up Resistor	200 Ohm
Minimum Output Pulse Width	1 microsecond
Maximum Operating Common Mode Voltage	250 V Continuous
Isolation: Channel to Channel	250V Continuous 1500V Transient
Power Consumption	1.5 W (300 mA @ 5 V)
Ambient Temperature: Operating Storage	-20 °C to 70 °C -40 °C to 85 °C
Humidity	5-95%, non-condensing
Torque, hold-down screws	Not to exceed 1 in-lb (0.11 N-m)
Torque, connector screws	5.22 in-lb (0.59 N-m)
Wire size range	22 to 14 AWG
Agency Approvals	CE, RoHS, DFARS; UKCA
Warranty	Lifetime

SNAP-AOV-5

Input	12-bit serial data
Output	0 to +10 Volts DC (floating)
Span	10 Volt span
Resolution	2.44 mV
Response Time (% of span/delta V/delta time)	99.9%/19.98 V/3 mS
DC Common Mode Rejection	>-120 dB
AC Common Mode Rejection	>-120 dB @ 60 Hz
Maximum Operating Common Mode Voltage	250 V
Common Mode Resistance	>1000 Megohms
Load Current	10 mA (floating)
Short Circuit Current Continuous	125 mA (typical)
Accuracy	0.1% of span
Gain Temperature Coefficient	50 PPM/°C
Offset Temperature Coefficient	20 PPM/°C
Power Requirements	5 Volts DC @ 150 mA
Ambient Temperature: Operating Storage	-20 °C to 70 °C -40 °C to 85 °C
Humidity	5-95%, non-condensing
Torque, hold-down screws	Not to exceed 1 in-lb (0.11 N-m)
Torque, connector screws	5.22 in-lb (0.59 N-m)
Wire size range	22 to 14 AWG
Agency Approvals	UL, CE, RoHS, DFARS, UKCA
Warranty	Lifetime

SNAP-AOV-25

Input	12-bit serial data (each channel)
Outputs	0 to +10 Volts DC
Span	10 Volts
Resolution	2.44 mV
Response Time (% of span/delta V/delta time)	99.9%/19.98 V/3 mS
DC Common Mode Rejection	>-120 dB
AC Common Mode Rejection	>-120 dB @ 60 Hz
Maximum Operating Common Mode Voltage	250 V
Common Mode Resistance	>1,000 Megohms
Load Current (nominal)	5 mA (each channel)
Short Circuit Output Current Continuous	40 mA per channel
Accuracy	0.1% of Span
Gain Temperature Coefficient	50 PPM/°C
Offset Temperature Coefficient	20 PPM/°C
Isolation	1500 V
Power Requirements	5 Volts DC (±0.15) @ 150 mA
Ambient Temperature: Operating Storage	-20 °C to 70 °C -40 °C to 85 °C
Humidity	5-95%, non-condensing
Torque, hold-down screws	Not to exceed 1 in-lb (0.11 N-m)
Torque, connector screws	5.22 in-lb (0.59 N-m)
Wire size range	22 to 14 AWG
Agency Approvals	UL, CE, FM, RoHS, DFARS; UKCA, NEBS
Warranty	Lifetime

SNAP-AOV-27

Input	12-bit serial data (each channel)
Outputs	-10 to +10 Volts DC
Span	20 Volts
Resolution	4.88 mV
Response Time (% of span/delta V/delta time)	99.9%/19.98 V/3 mS
DC Common Mode Rejection	>-120 dB
AC Common Mode Rejection	>-120 dB @ 60 Hz
Maximum Operating Common Mode Voltage	250 V
Common Mode Resistance	>1,000 Megohms
Load Current (nominal)	5 mA (each channel)
Short Circuit Output Current Continuous	40 mA per channel
Accuracy	0.1% of Span
Gain Temperature Coefficient	50 PPM/°C
Offset Temperature Coefficient	20 PPM/°C
Power Requirements	5 Volts DC (± 0.15) @ 150 mA
Ambient Temperature: Operating	-20 °C to 70 °C
Storage	-40 °C to 85 °C
Humidity	5-95%, non-condensing
Torque, hold-down screws	Not to exceed 1 in-lb (0.11 N-m)
Torque, connector screws	5.22 in-lb (0.59 N-m)
Wire size range	22 to 14 AWG
Agency Approvals	UL, CE, FM, RoHS, DFARS; UKCA
Warranty	Lifetime

SNAP-AOVA-8

Excitation Range	18 TO 32 VDC
Excitation Current Required	200mA @ 32VDC, 250mA @ 24VDC, 350mA @ 18VDC
24V Excitation Fault Recovery Time	15 mS nominal
Power Requirement (from the rack)	5 VDC (± 0.15) @ 150 mA
Maximum Operating Common Mode Voltage	250 volts
Isolation	1500 V (transient)
DC Common Mode Rejection	>-120 dB
AC Common Mode Rejection	>-120 dB @ 60 Hz
Data Refresh Time	9 mS nom (update 1 ch/ms)
Ambient Temperature:	
Operating	-20 to 70 °C
Storage	-40 °C to 85 °C
Humidity	5-95%, non-condensing
Torque, hold-down screws	Not to exceed 1 in-lb (0.11 N-m)
Torque, connector screws	5.22 in-lb (0.59 N-m)
Wire size range	22 to 14 AWG
Agency Approvals	UL, CE, RoHS, DFARS; UKCA
Warranty	Lifetime

Voltage Outputs

Output Range (Resolution)	0 to 5 VDC (1.22 mV) 0 to 10 VDC (2.44 mV) -5 to +5 VDC (2.44 mV) -10 to +10 VDC (4.88 mV)
Load Current	+/-10 mA min. each voltage output channel)
Short Circuit Current	16 mA Typ.
Accuracy	0.1% of span
Drift:	
Gain Temperature Coefficient	30 PPM / °C
Offset Temperature Coefficient	15 PPM / °C

Current Outputs

Output Range (Resolution)	4 to 20 mA (4 microamps) 0 to 20 mA (5 microamps)
Maximum Loop Resistance	750 Ohms (each current output channel)
Open Circuit Volts	27 VDC max. (24 VDC typical)
Accuracy	0.1% of span
Drift:	
Gain Temperature Coefficient	30 PPM / °C
Offset Temperature Coefficient	15 PPM / °C

SERIAL MODULE SPECIFICATIONS

SNAP-SCM-232 and SNAP-SCM-485-422

Baud rates	300–115,200*
Channel-to-channel isolation	750 V _{RMS}
Logic supply voltage	5.0 VDC
Logic supply current	250 mA DC
Number of ports per module	2 (1 if SNAP-SCM-485-422 in 4-wire mode)
Max. number of modules per rack**	8
Maximum cable length, point-to-point (SNAP-SCM-232)	50 feet
Maximum cable length, multidrop (SNAP-SCM-485-422)	1,000 feet at 115,200 Kbd
Processor compatibility	SNAP PAC R-series controllers and SNAP PAC EB brains, both standard wired and Wired+Wireless models. Also SNAP-B3000-ENET, SNAP-ENET-RTC, SNAP-ENET-S64, SNAP-UP1-ADS, and SNAP-UP1-M64.
Operating temperature	-20 to 70 °C
Storage temperature	-30 to 85 °C
Torque, hold-down screws	Not to exceed 1 in-lb (0.11 N-m)
Torque, connector screws	5.22 in-lb (0.59 N-m)
Agency Approvals	UL, CE, FM, RoHS, DFARS; UKCA ATEX (SNAP-SCM-485-422 only) NEBS (SNAP-SCM-232 only)
Warranty	30 months

* Module performance is limited by the number of serial modules on the SNAP rack. Each rack backplane provides approximately 2.5 Mbps of bandwidth.

** Maximum number of modules per rack assumes a 4A power supply (for example, SNAP-PS5).

SNAP-SCM-ST2

Frequency Range	0.13–50,000 Hz
Pulse Width Range ¹	3.84 Sec to 10 μSec
Pulse Width Resolution	0–2 Hz, 2–30 Hz, 30–50,000 Hz
Output Frequency Accuracy	To calculate error (in Hz) for the desired frequency, use this equation and the resolution graphs on the next page: $\text{Frequency Error (+/-)} = \text{Desired Frequency} - (1 \div (\text{Pulse Width Resolution} + (1 \div \text{Desired Frequency})))$
Output Format	CMOS/TTL Compatible
Logic Supply Voltage	5.0 VDC
Logic Supply Current	200 mA
Compatible I/O Processors	SNAP PAC R-series controllers and EB-series brains with R9.1a or newer firmware

SERIAL MODULE SPECIFICATIONS

Duty Cycle	Fixed at 50%
Number of Ports per Module	2
Operating Temperature Range	-20–60 °C
Storage Temperature Range	-30–85 °C
Torque, hold-down screws	Not to exceed 1 in-lb (0.11 N-m)
Torque, connector screws	5.22 in-lb (0.59 N-m)
Agency approvals	CE, RoHS, DFARS
Warranty	30 months from date of manufacture

¹Pulse Width is equal to one-half the period.

SNAP-SCM-CAN2B

Baud rates	10–1000 Kbps*
Logic supply voltage	5.0 VDC
Logic supply current	250 mA DC
Number of ports per module	1
Max. number of modules per rack**	8
Processor compatibility	SNAP PAC R-series controllers and SNAP PAC EB brains, both standard wired and Wired+Wireless models, with firmware 9.2a or newer.
Operating temperature	-20 to 70 °C
Storage temperature	-30 to 85 °C
Torque, hold-down screws	Not to exceed 1 in-lb (0.11 N-m)
Torque, connector screws	5.22 in-lb (0.59 N-m)
Agency Approvals	UL, CE, FM, RoHS, DFARS
Warranty	30 months from date of manufacture

* Module performance is limited by the number of serial modules on the SNAP rack. Each rack backplane provides approximately 2.5 Mbps of bandwidth.

** Maximum number of modules per rack assumes a 4A power supply (for example, SNAP-PS5).

BREAKOUT BOARD AND CABLE SPECIFICATIONS

SNAP-TEX-32

Feature	SNAP-TEX-32	SNAP-TEX-FB16-H (Obsolete)	SNAP-TEX-FB16-L (Obsolete)
Use with I/O modules	2- or 4-point analog inputs/outputs; 4-point digital inputs/outputs*; 8-, 16-, or 32-point digital and analog outputs (not thermocouples)	4-point digital inputs and outputs 16- and 32-pt digital inputs/outputs	4-point digital inputs and outputs 16- and 32-pt digital inputs/outputs
Use with cables	SNAP-TEX-CBE6 (even pins connected), SNAP-TEX-CBO6 (odd pins connected), or SNAP-TEX-CBS6 (no connections), depending on module. SNAP-HD-20F6 with a SNAP-AOVA-8 module.	4-ch modules: SNAP-TEX-CBO6 (odd pins connected)** or SNAP-TEX-CBS6 (straight-through), depending on module. 16-ch modules: SNAP-HD-ACF6 32-ch modules: SNAP-HD-CBF6	4-ch modules: SNAP-TEX-CBO6 (odd pins connected)** or SNAP-TEX-CBS6 (straight-through), depending on module. 16-ch modules: SNAP-HD-ACF6 32-ch modules: SNAP-HD-CBF6
Connectors	32 spring connectors; accommodates eight 4-point modules	16 spring connectors; accommodates four 4-point modules	16 spring connectors; accommodates four 4-point modules
Fusing	none	1 A, 250 V, fast-acting fuse for each I/O point (16 total). Replace with Opto 22 PN FUSE01G4	1 A, 250 V, fast-acting fuse for each I/O point (16 total). Replace with Opto 22 PN FUSE01G4
Indicators	none	1 blown-fuse LED per fuse (16 LEDs total)	1 blown-fuse LED per fuse (16 LEDs total)
Bussed power	none	120–240 V	12–24 V
Agency Approvals	CE, RoHS, DFARS; UKCA	UL, CE, RoHS, DFARS	UL, CE, RoHS, DFARS; UKCA
Warranty	30 months	30 months	30 months

* Can be used with digital outputs but does not have fuses. SNAP-TEX-FB16 boards have fuses; they are better for digital outputs.

** **IMPORTANT:** Do NOT USE the FB16 breakout boards with a SNAP-TEX-CBE6 cable. The board has odd pins connected; the cable has even pins connected.

SNAP-IDC-HDB and SNAP-ODC-HDB

SNAP-IDC-HDB and SNAP-IDC-HDB-FM (Obsolete) Breakout Racks for High-Density Digital Input Modules	
Used with	SNAP-IDC-32, SNAP-IDC-32-FM, SNAP-IDC-32N, and SNAP-IDC-32DN
Connectors	40-pin header connects to 32-point input module using SNAP-HD-BF6 header cable. 32 signal input connectors; each signal connector has a corresponding common connector. For each zone of 8 signal inputs, 1 connection for either module common or field common. Wire size for field connectors: 16-20 AWG
Indicators	1 LED for On/Off status of each signal input (32 signal LEDs total) 1 power status LED for each zone of 8 signal inputs (4 power LEDs total)
Fusing	2 fuses (Module Common, Field Common) for each zone of 8 signal inputs (8 fuses total) 1 A fuses; replace with Pudenz 1 A automobile mini-fuse or equivalent.
Jumpers	For each zone of 8 signal inputs, 1 jumper controls whether module common or field common is used. Set jumpers to X position for digital input modules.
Voltage	32 VDC maximum, 12-24 VDC nominal
Agency Approvals	SNAP-IDC-HDB: UL, CE, RoHS, DFARS SNAP-IDC-HDB-FM: FM, CE, RoHS, DFARS
Warranty	30 months from date of manufacture

SNAP-ODC-HDB and SNAP-ODC-HDB-FM (Obsolete) Breakout Racks for High-Density Digital Output Modules	
Used with	SNAP-ODC-32-SRC, SNAP-ODC-32-SRC-FM (obsolete), SNAP-ODC-32-SNK, and SNAP-ODC-32-SNK-FM (obsolete)
Connectors	40-pin header; connects to 32-point sourcing or sinking module using SNAP-HD-BF6 header cable. 32 signal output connectors; each signal connector has a corresponding common connector. For each zone of 8 signal outputs, 1 connection for either module common or field common. Wire size for field connectors: 16-20 AWG
Indicators	1 LED for On/Off status of each signal output (32 signal LEDs total) 1 power status LED for each zone of 8 signal outputs (4 power LEDs total)
Fusing	1 A fuses; 1 fuse for each signal output (32 signal fuses total) Replace with Pudenz 1 A automobile mini-fuse or equivalent.
Jumpers	For each zone of 8 signal inputs, 1 jumper controls whether module common or field common is used. Set jumpers to Z position for digital output modules.
Voltage	32 VDC maximum, 12-24 VDC nominal
Agency Approvals	SNAP-ODC-HDB: UL, CE, RoHS, DFARS SNAP-ODC-HDB-FM: FM, CE, RoHS, DFARS
Warranty	30 months from date of manufacture

SNAP-UDC-HDB

SNAP-UDC-HDB Breakout Rack for High-Density Digital Input and Output Modules	
Used with	SNAP-IDC-32, SNAP-IDC-32-FM SNAP-IDC-32N, SNAP-IDC-32D, SNAP-IDC-32DN SNAP-ODC-32-SNK, SNAP-ODC-32-SNK-FM SNAP-ODC-32-SRC, SNAP-ODC-32-SRC-FM
Connectors	40-pin header connects to 32-point module using SNAP-HD-BF6 cable. 64 spring-clamp terminal block provides 1 connection for each of 32 channels, 4 connections per 8-channel zone for field common, and 4 connections per 8-channel zone for module common.
Wire size	Field connector: 12-28 AWG
Indicators	1 LED status indicator for each point (32 LEDs total)
Jumpers	When using any SNAP-IDC-32 input module, install all four jumpers (JP1–JP4) in X positions. When using any SNAP-ODC-32 output module, install all four jumpers in Z positions.
Voltage	32 VDC maximum, 12–24 VDC nominal
Agency Approvals	UL, CE, RoHS, DFARS
Warranty	30 months from date of manufacture

SNAP-UDC-HDB-G4

SNAP-UDC-HDB-G4 Breakout Rack for High-Density Digital Input or Output Module	
Used with	Outputs: SNAP-ODC-32-SNK or SNAP-ODC-32-SNK-FM (all G4 modules must be the same voltage) Inputs: SNAP-IDC-32DN for 5 V G4 modules; SNAP-IDC-32N for 15 V or 24 V G4 modules
Connectors	40-pin header connects to 32-point module using SNAP-HD-BF6 cable. 64 spring-clamp terminals provide 2 connections for each of 32 channels. Additional 4 spring-clamp terminals are for logic power + and – (2 each).
Wire size	Field connector: 12-28 AWG
Indicators	1 LED for logic power; 1 LED for G4 fuse test
Jumpers	When using a SNAP-ODC-32-SNK output module, install JP1 in the negative (–) position. When using a SNAP-IDC-32 input module, install JP1 in the positive (+) position.
Voltage	32 VDC maximum, 12–24 VDC nominal
Agency Approvals	UL, CE, RoHS, DFARS
Warranty	30 months from date of manufacture

SNAP-HD-ACF6, SNAP-HD-CBF6, and SNAP-HD-BF6

Feature	SNAP-HD-ACF6	SNAP-HD-CBF6	SNAP-HD-BF6
Cable length	6 feet (1.8 meters)	6 feet (1.8 meters)	6 feet (1.8 meters)
Connectors	Two-cable assembly; 16-pin connector at module end; flying leads at other end	One 40-pin connector at module end; flying leads at other end	One connector at module end; one connector at breakout board end
Wires	Pre-stripped, tinned, color-coded, 22-gauge wires	Pre-stripped, tinned, color-coded, 24-gauge wires	24-gauge wires
Use with	Modules: SNAP-IAC-16 SNAP-IAC-A-16 SNAP-IAC-K-16 SNAP-IDC-16 SNAP-IDC-HT-16	Modules: SNAP-IDC-32 SNAP-IDC-32-FM SNAP-IDC-32N SNAP-IDC-32D SNAP-IDC-32DN SNAP-ODC-32-SNK SNAP-ODC-32-SNK-FM SNAP-ODC-32-SRC SNAP-ODC-32-SRC-FM SNAP-AIV-32 SNAP-AIV-32-FM	Modules to breakout boards (regular and -FM versions): SNAP-IDC-32 to SNAP-IDC-HDB or SNAP-UDC-HD SNAP-IDC-32N to SNAP-IDC-HDB, SNAP-UDC-HDB, or SNAP-UDC-HDB-G4 SNAP-IDC-32D to SNAP-IDC-HDB or SNAP-UDC-HDB SNAP-IDC-32DN to SNAP-IDC-HDB, SNAP-UDC-HDB, or SNAP-UDC-HDB-G4 SNAP-ODC-32-SNK to SNAP-ODC-HDB, SNAP-UDC-HDB, or SNAP-UDC-HDB-G4 SNAP-ODC-32-SRC to SNAP-ODC-HDB or SNAP-UDC-HDB SNAP-AIV-32 to SNAP-AIV-HDB SNAP-AIMA-32 to SNAP-AIMA-HDB SNAP-AIMA-32 to SNAP-AIV-HDB*
Agency Approvals	CE, RoHS, DFARS	CE, RoHS, DFARS	CE, RoHS, DFARS
Warranty	30 months	30 months	30 months

* Special application; see wiring diagrams.

SNAP-TEX-CB06, SNAP-TEX-CBE6, and SNAP-TEX-CBS6

Feature	SNAP-TEX-CB06	SNAP-TEX-CBE6	SNAP-TEX-CBS6
Cable length	6 feet (1.8 meters)	6 feet (1.8 meters)	6 feet (1.8 meters)
Connector	8 pins, 0.2 in. (5.08 mm) center-to-center	8 pins, 0.2 in. (5.08 mm) center-to-center	8 pins, 0.2 in. (5.08 mm) center-to-center
Wires	8 pre-stripped, tinned, color-coded, 18 gauge	8 pre-stripped, tinned, color-coded, 18 gauge	8 pre-stripped, tinned, color-coded, 18 gauge
Bussing	Odd-numbered pins connected	Even-numbered pins connected*	No connections
Agency Approvals	CE, RoHS, DFARS	CE, RoHS, DFARS	CE, RoHS, DFARS
Warranty	30 months	30 months	30 months

*Do NOT USE the CBE6 with a SNAP-TEX-FB16-H or -L breakout board. The FB16s have odd-numbered pins connected.

B: Dimensional Diagrams

INTRODUCTION

This appendix includes dimensional diagrams for SNAP PAC System hardware:

SNAP PAC controllers	page 150
SNAP PAC brains	page 153
SNAP power supplies	page 154
SNAP digital I/O modules	page 156
SNAP high-density digital modules	page 161
SNAP analog I/O modules	page 163
SNAP serial modules	page 175
Breakout boards	page 178

For N-TRON switch and access point dimensions, see the data sheet for the part number. Data sheets are available on our website, www.opto22.com.

SNAP PAC CONTROLLER DIAGRAMS

SNAP-PAC-S1 Standalone Controller

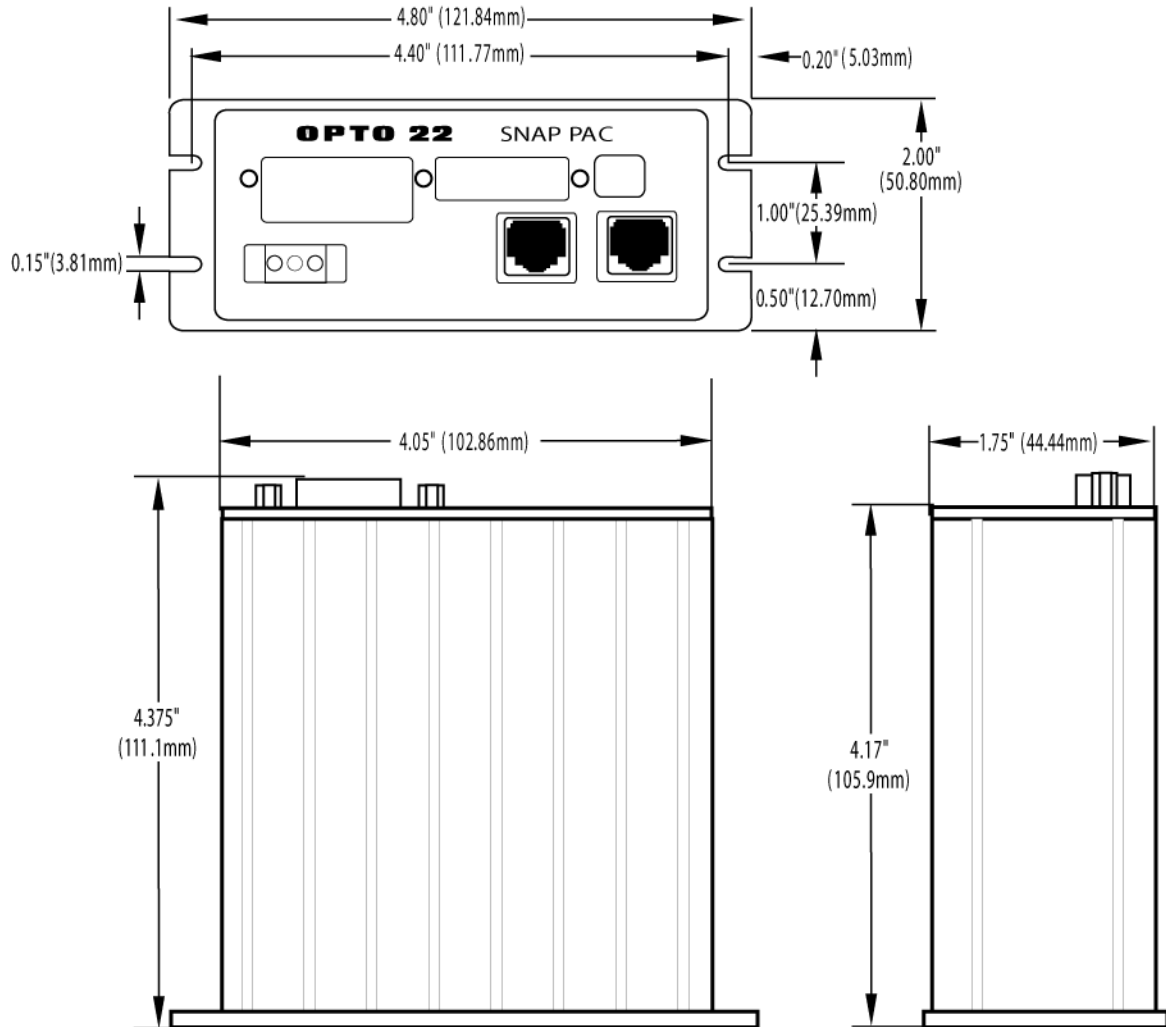

SNAP-PAC-S2 Standalone Controller

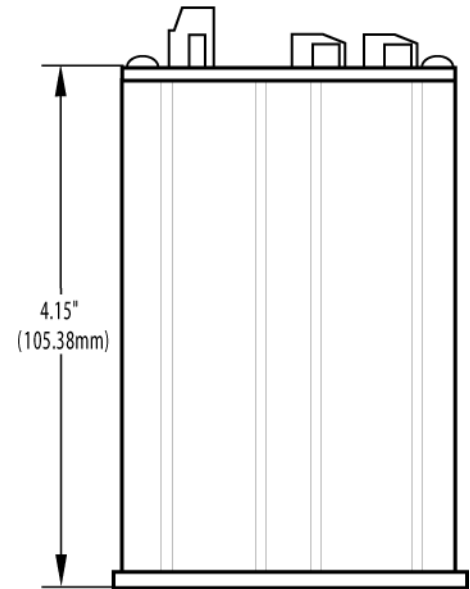
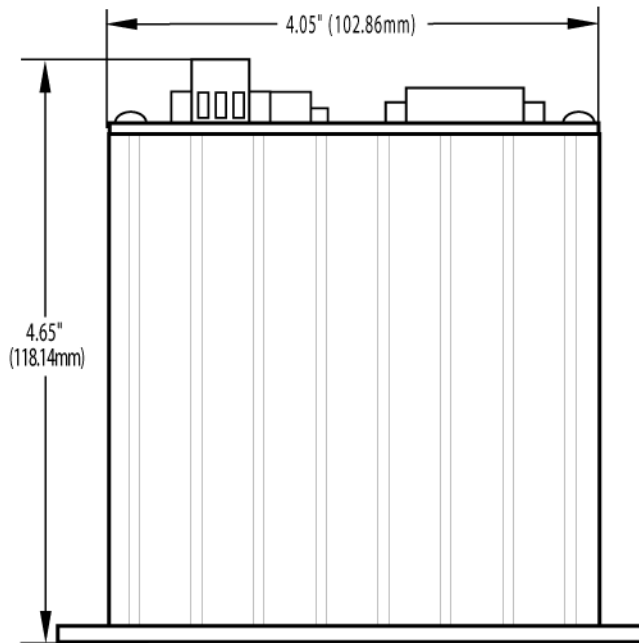
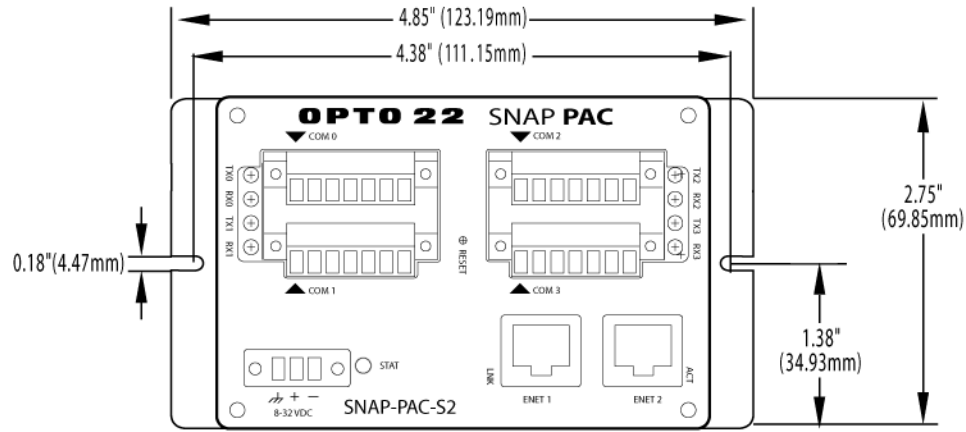

SNAP-PAC-R1, SNAP-PAC-R1-FM, and SNAP-PAC-R2, Rack-mounted Controllers

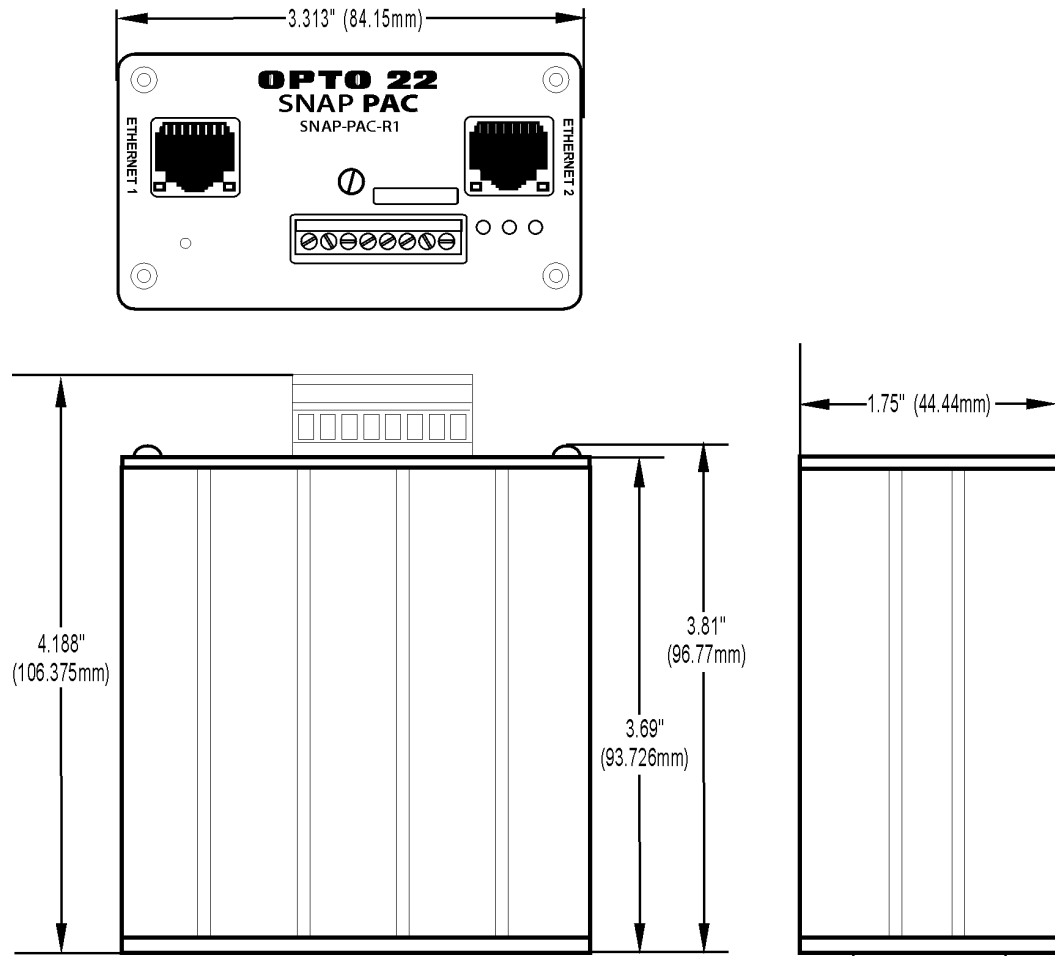

SNAP PAC BRAIN DIAGRAMS

SNAP-PAC-SB1 and SNAP-PAC-SB2 Serial Brains

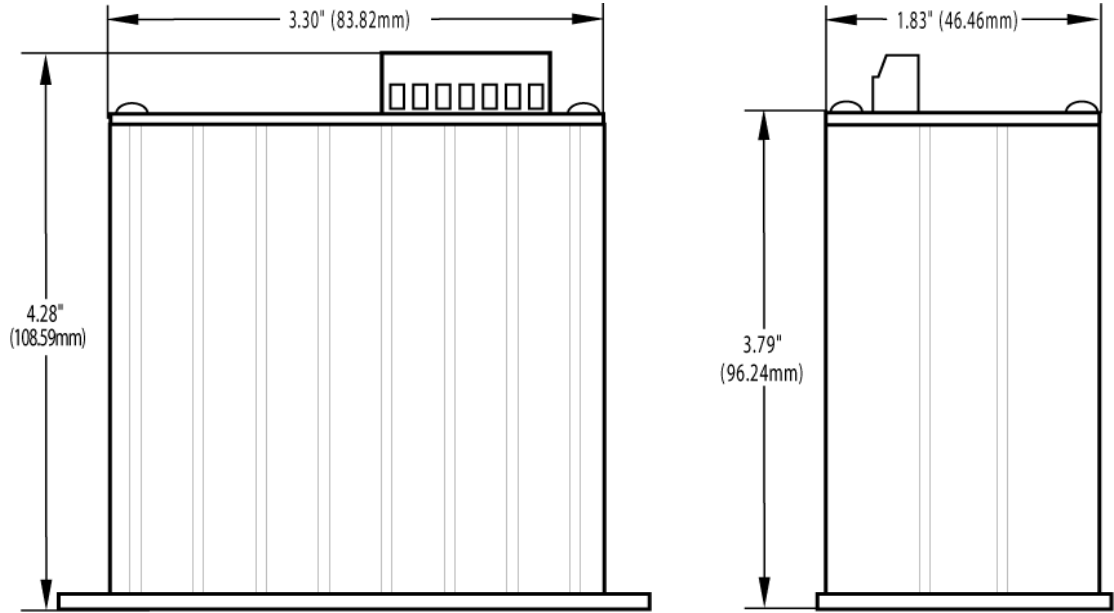

SNAP POWER SUPPLIES DIAGRAMS

SNAP-PS5, SNAP-PS24, and SNAP-PS5-24DC

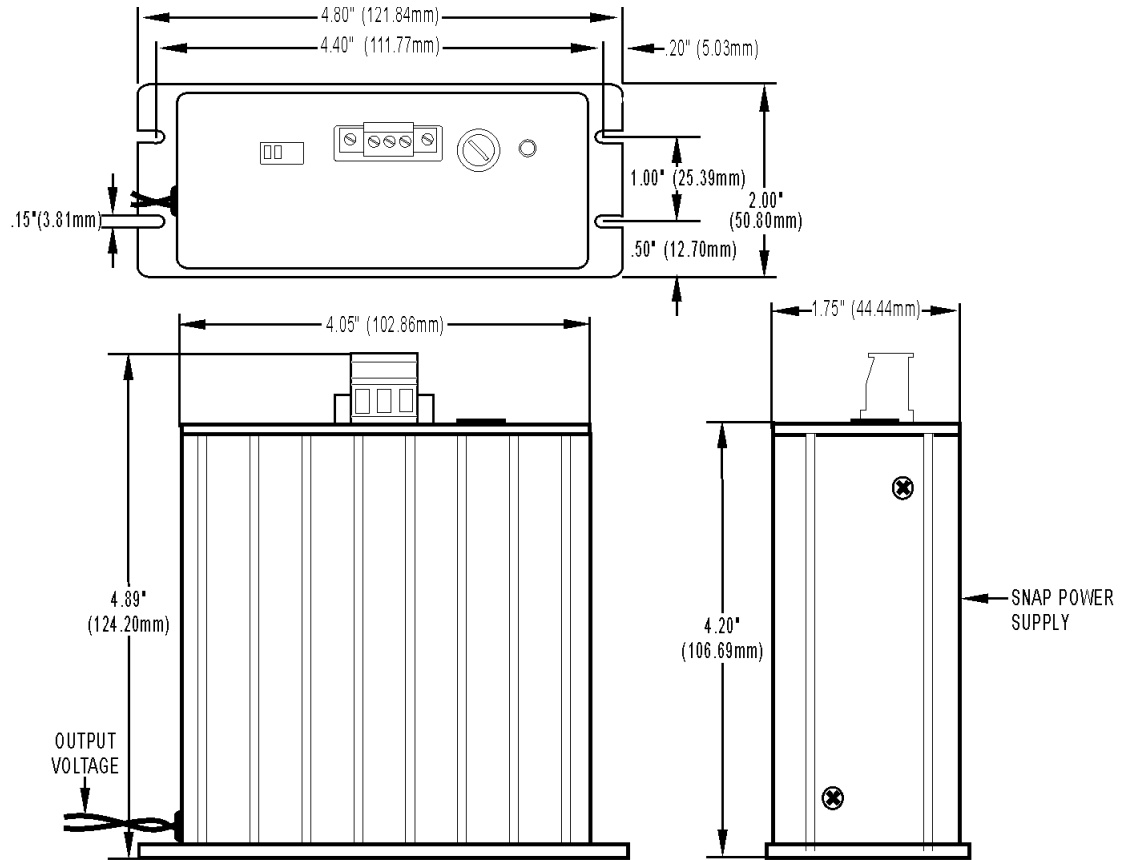

SNAP-PS5U and SNAP-PS24U

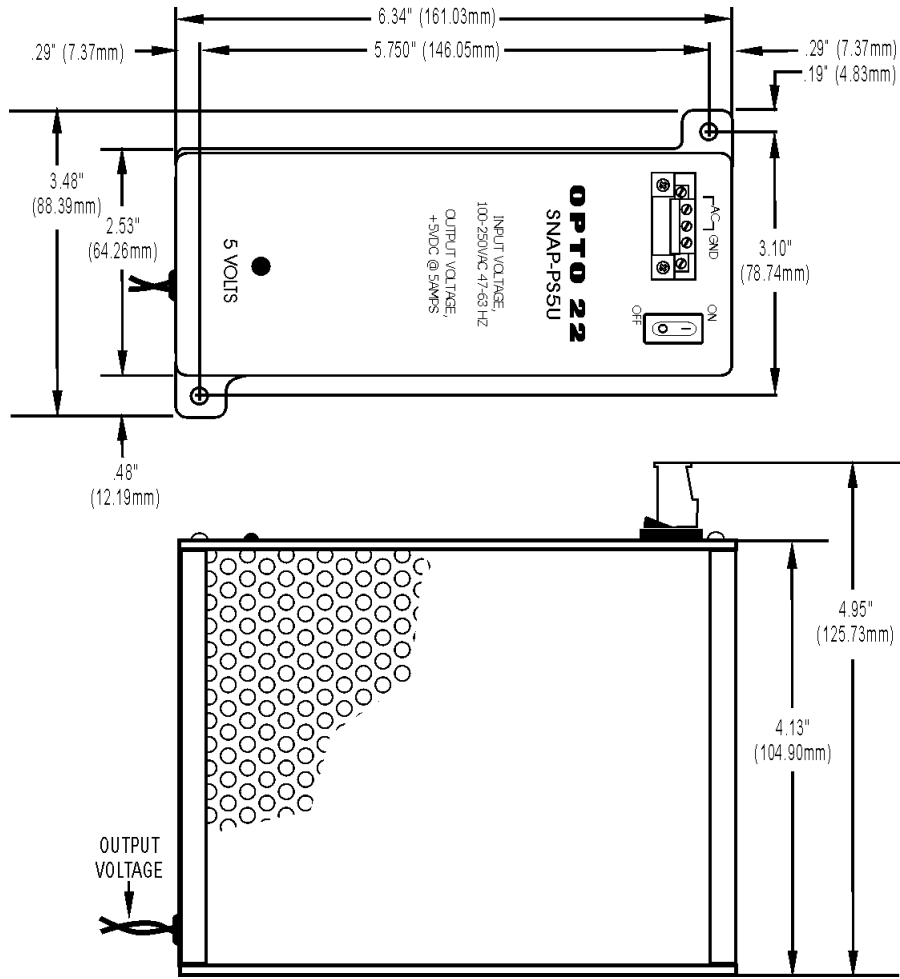

SNAP DIGITAL I/O MODULES DIAGRAMS

SNAP Digital Input Modules—All Modules except MA

For high-density digital modules, see diagrams starting on [page 161](#).

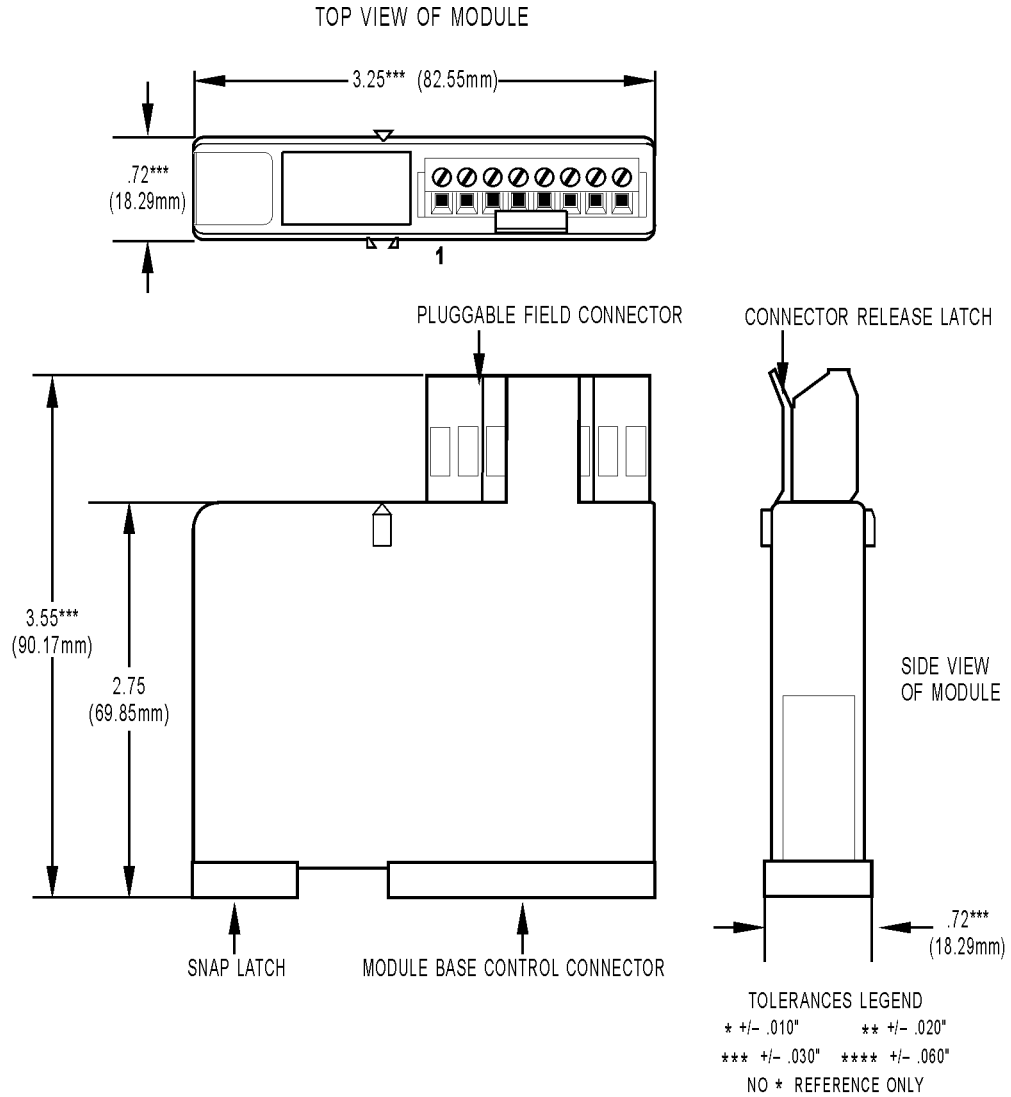

SNAP Digital Input Modules—MA Modules

TOP VIEW OF MODULE

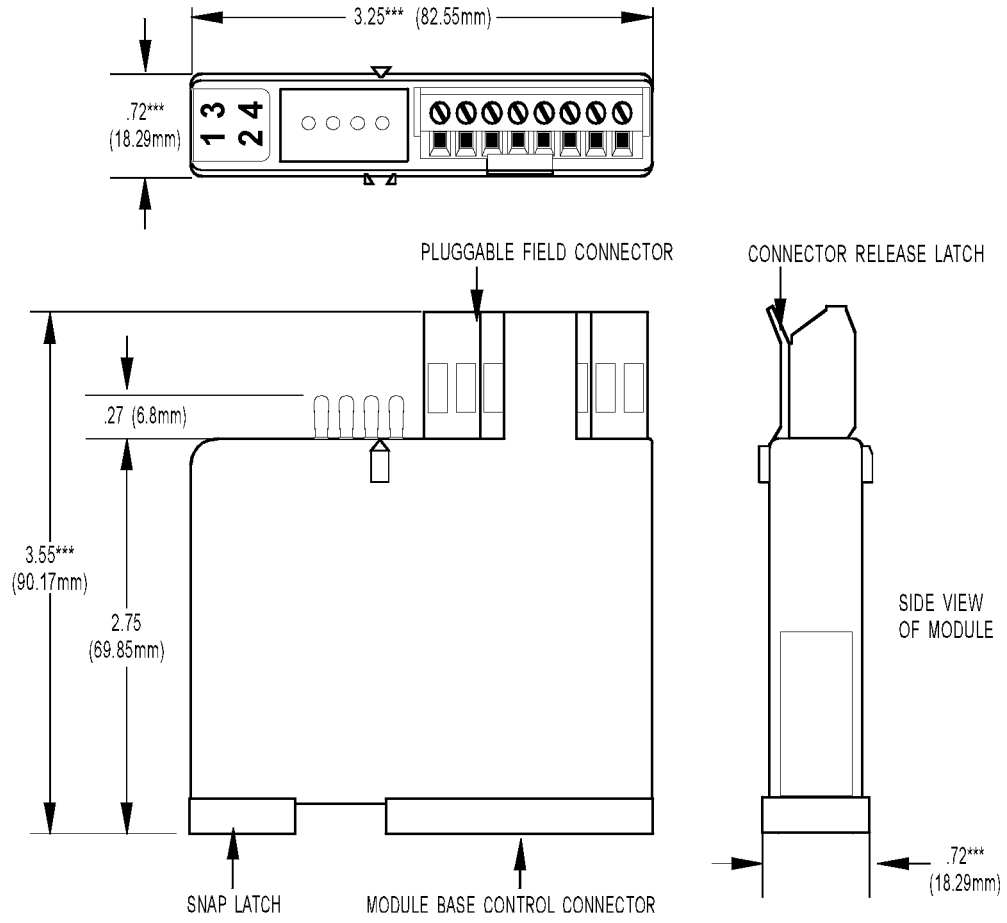

TOLERANCES LEGEND
 * +/- .010" ** +/- .020"
 *** +/- .030" **** +/- .060"
 NO * REFERENCE ONLY

SNAP Digital Output Modules—All Modules except MA and Mechanical Power Relay

For high-density digital modules, see diagrams starting on [page 161](#).

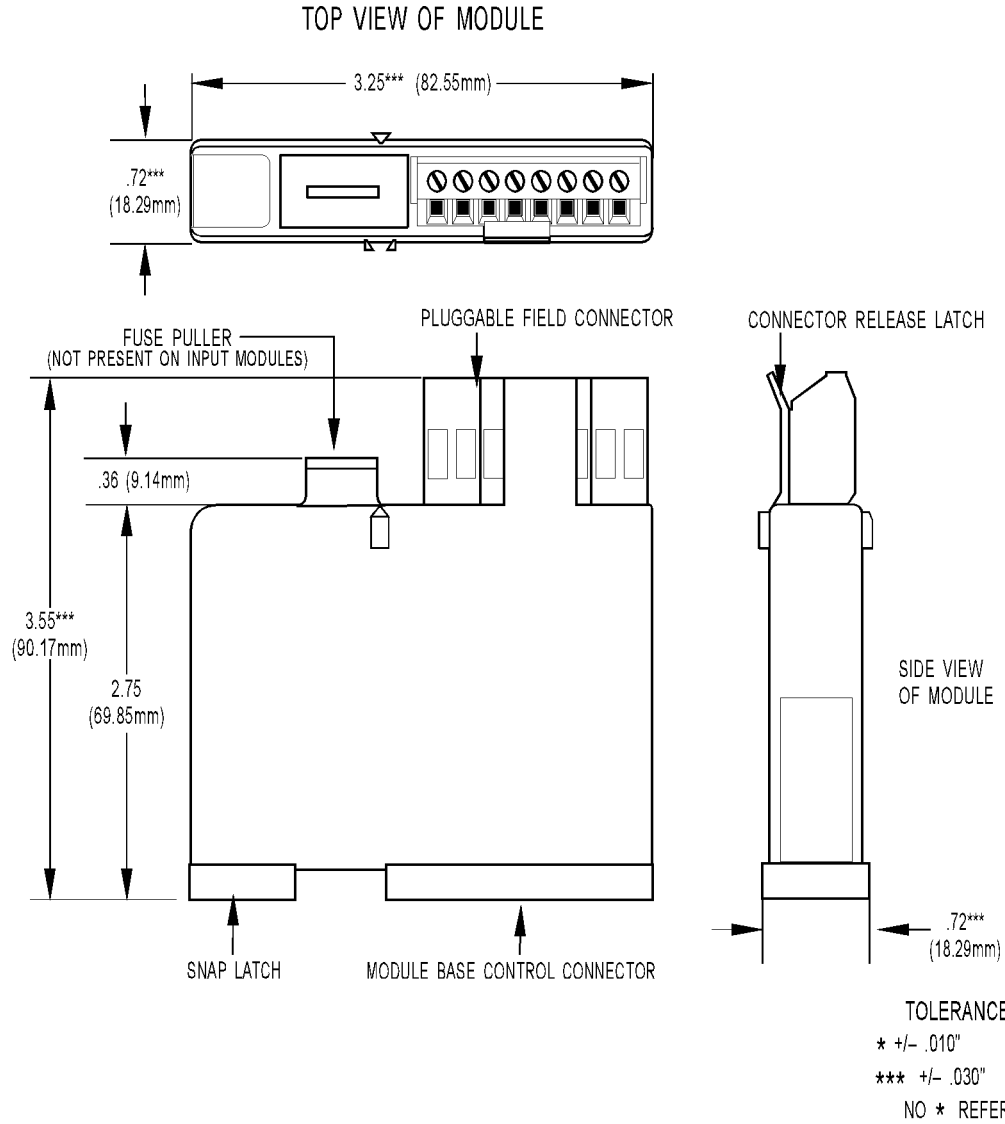

SNAP Digital Output Modules—MA Modules

TOP VIEW OF MODULE

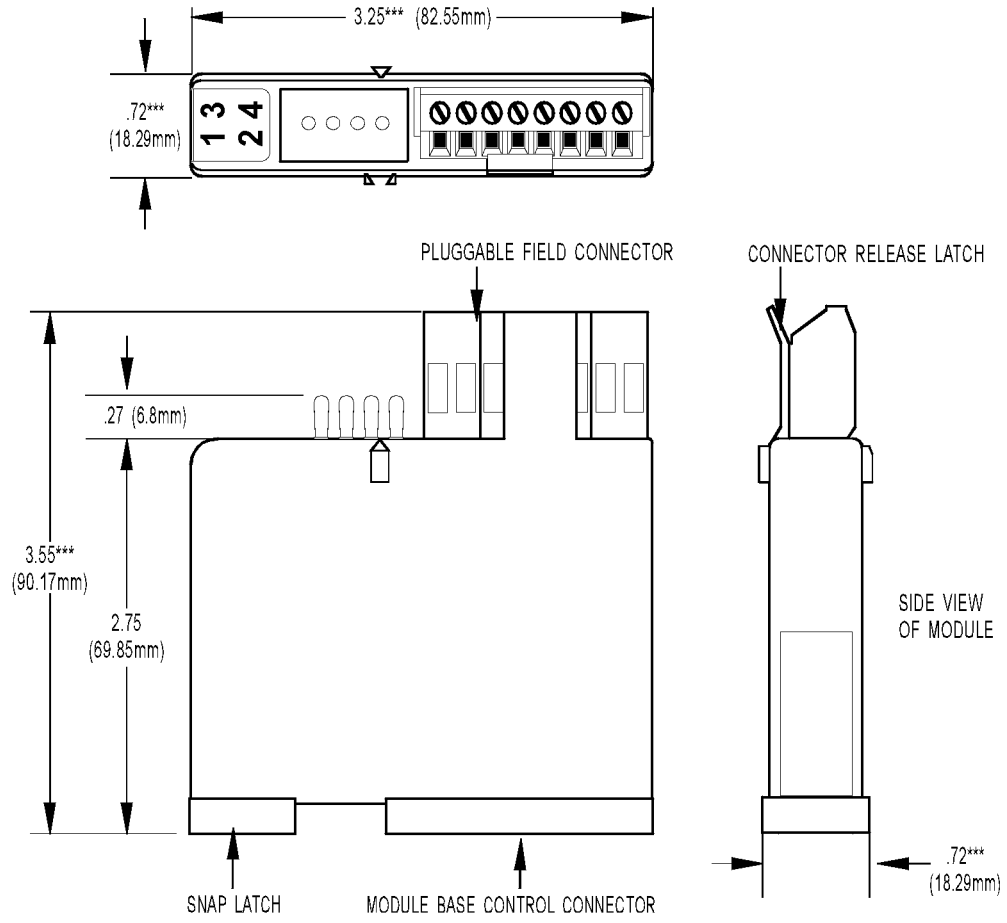

TOLERANCES LEGEND
 * +/- .010" ** +/- .020"
 *** +/- .030" **** +/- .060"
 NO * REFERENCE ONLY

SNAP Digital Output Modules—Mechanical Power Relay

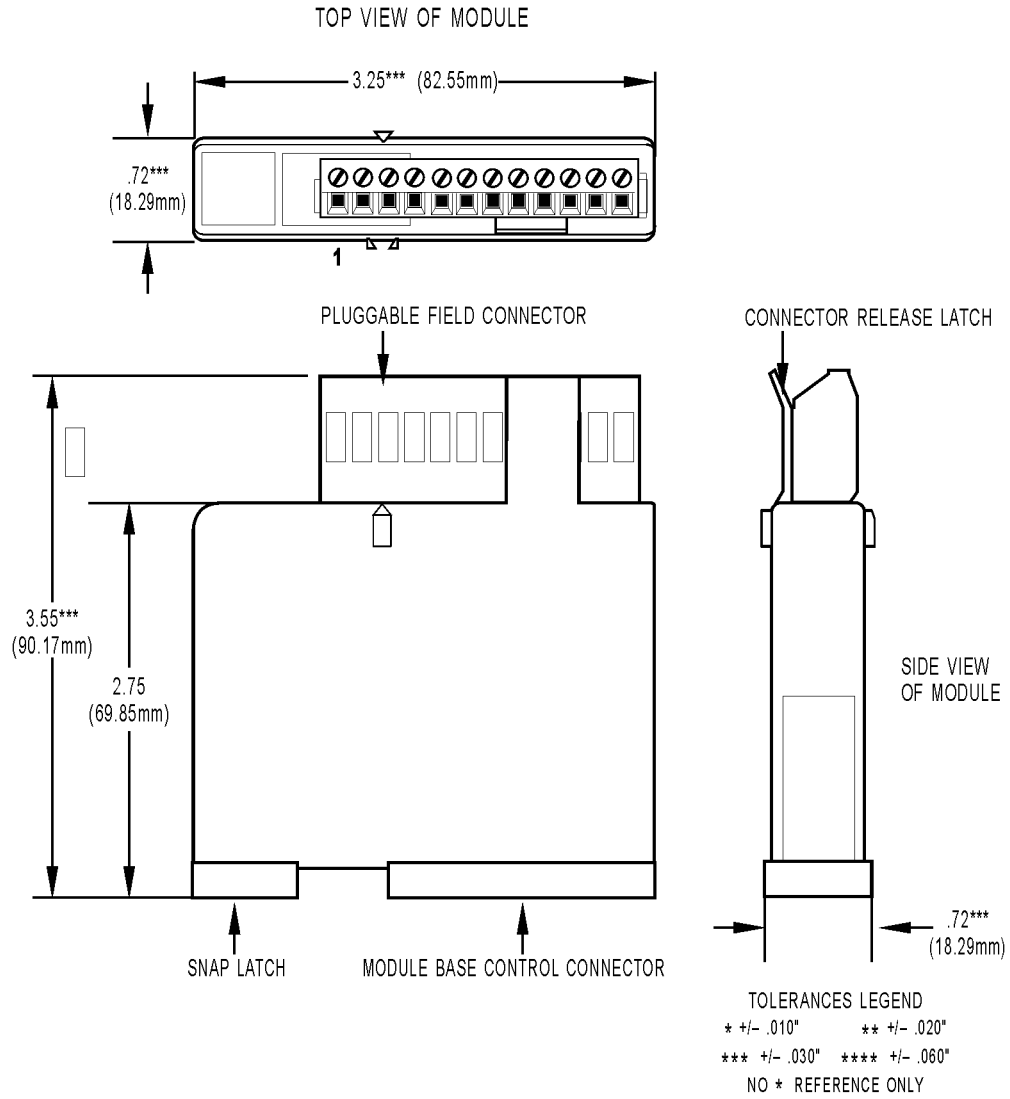

SNAP HIGH-DENSITY DIGITAL MODULES

SNAP 16-Point Digital Modules

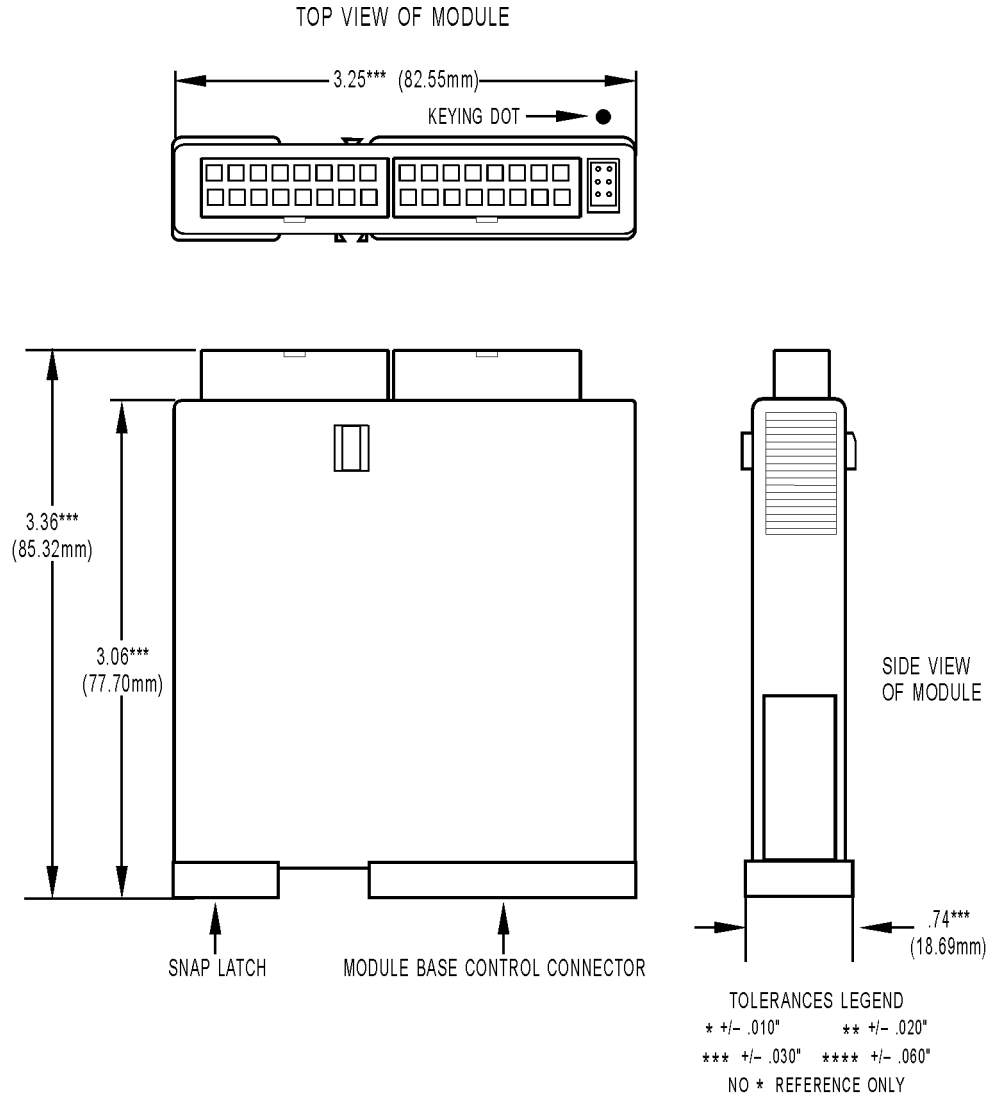

SNAP 32-Point Digital Modules

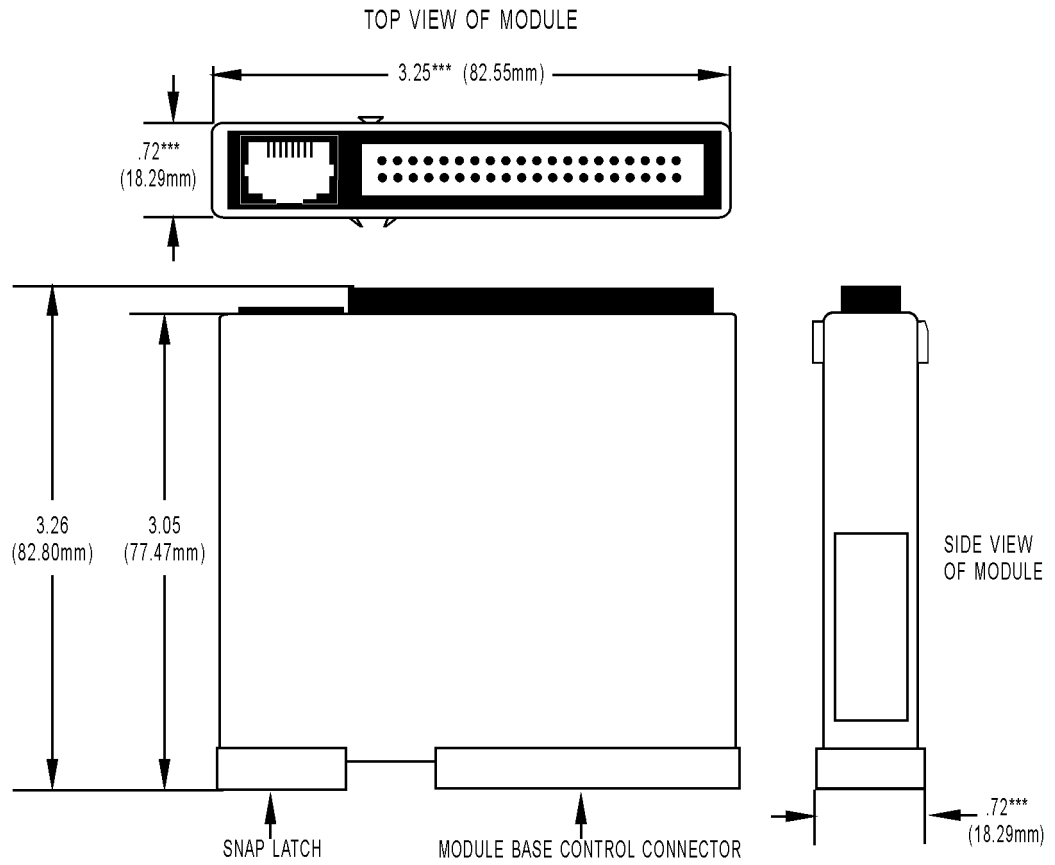

TOLERANCES LEGEND
 * +/- .010" ** +/- .020"
 *** +/- .030" **** +/- .060"
 NO * REFERENCE ONLY

SNAP ANALOG I/O MODULES

SNAP Analog Input Modules—Most Two- and Four-Channel Modules

For isolated analog input modules, see [page 169](#).

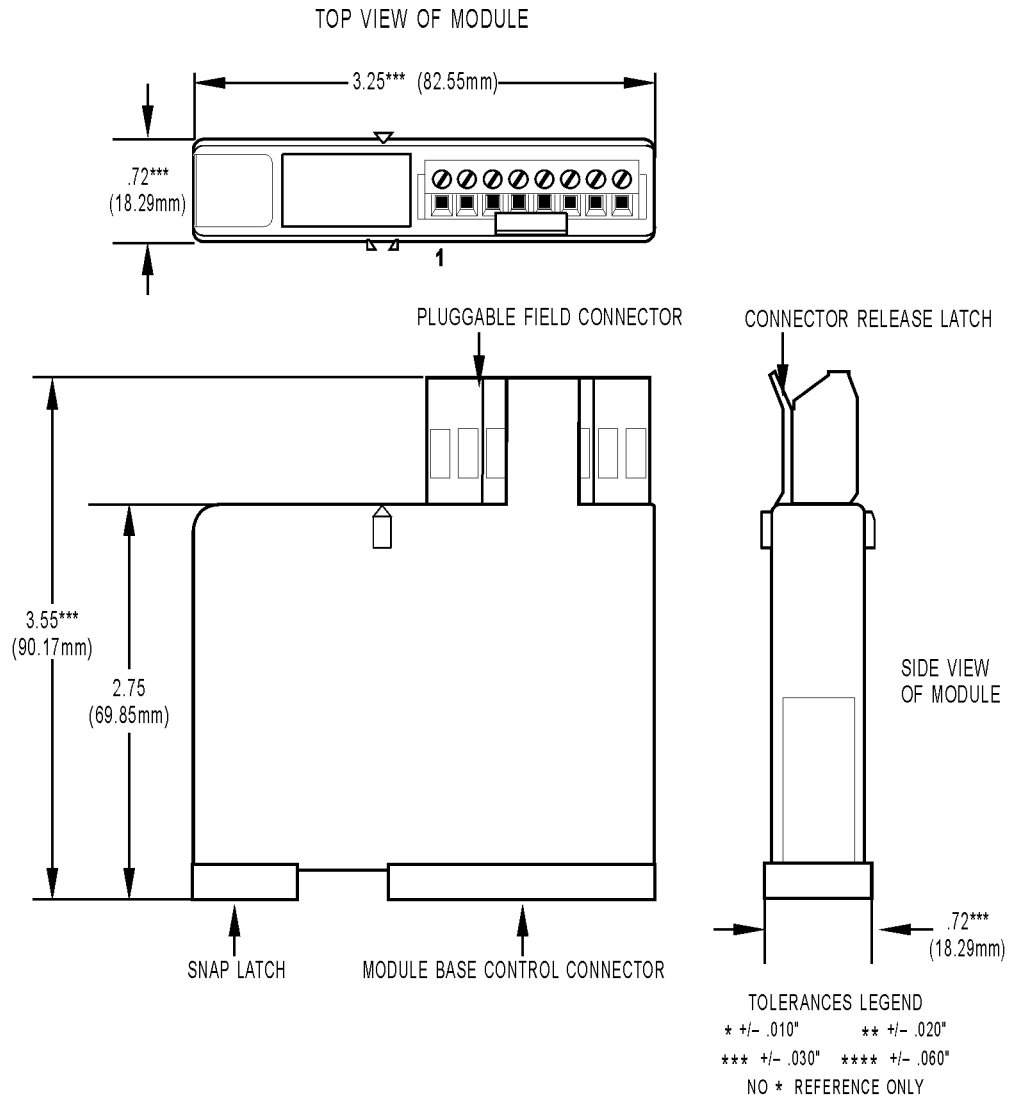

SNAP Analog Input Modules—SNAP-AITM-8

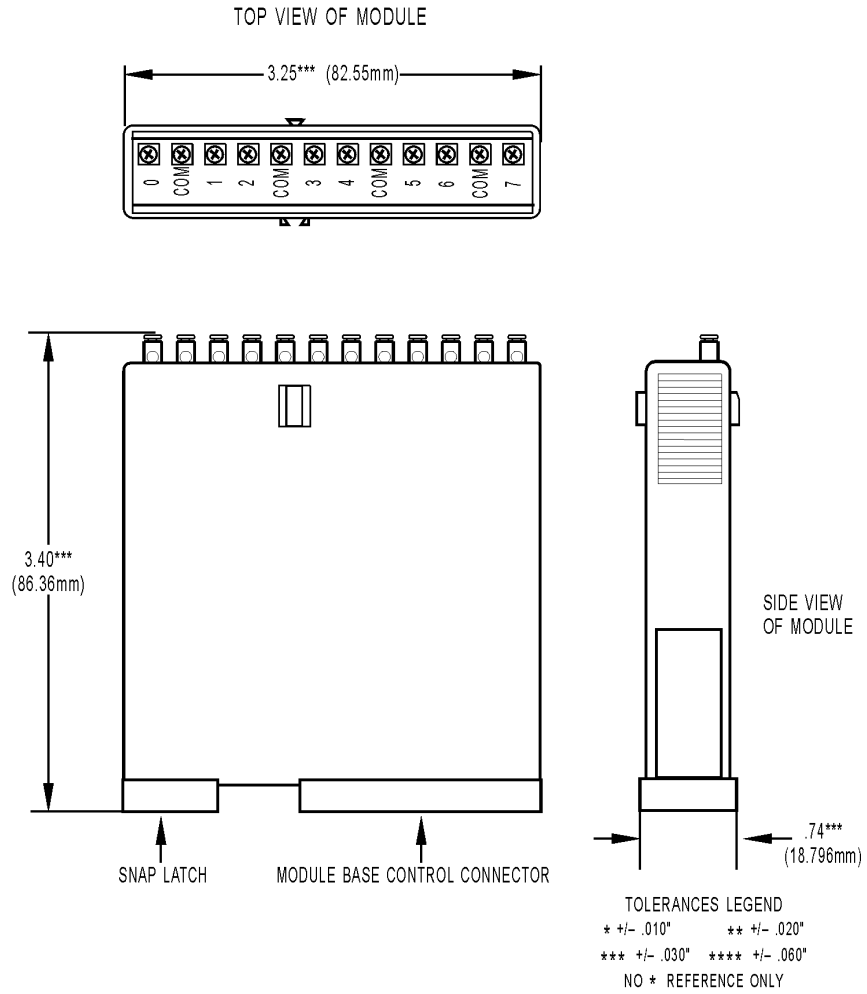

SNAP Analog Input Modules—SNAP-AICTD-8, SNAP-AIMA-8, and SNAP-AIV-8

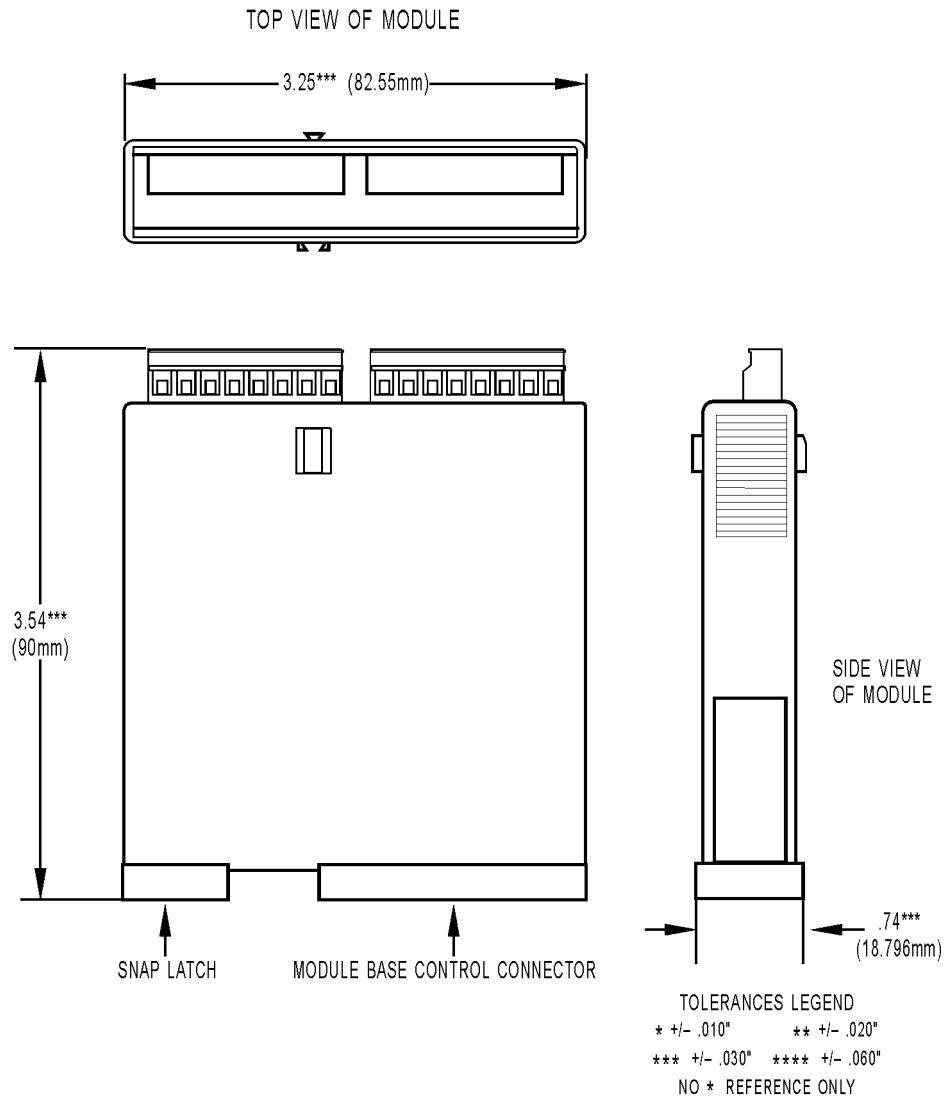

SNAP-AIR400K-8 Analog Input Module

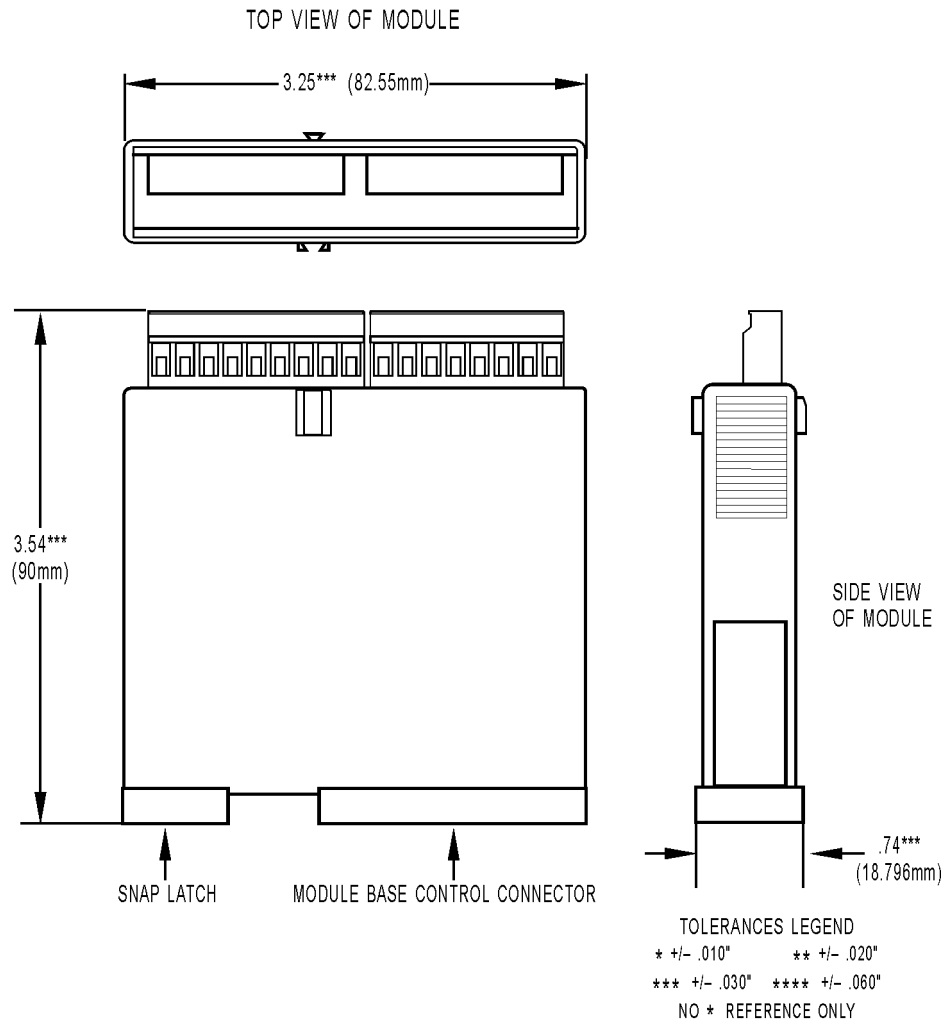

SNAP-AIRTD-8U Analog Input Module

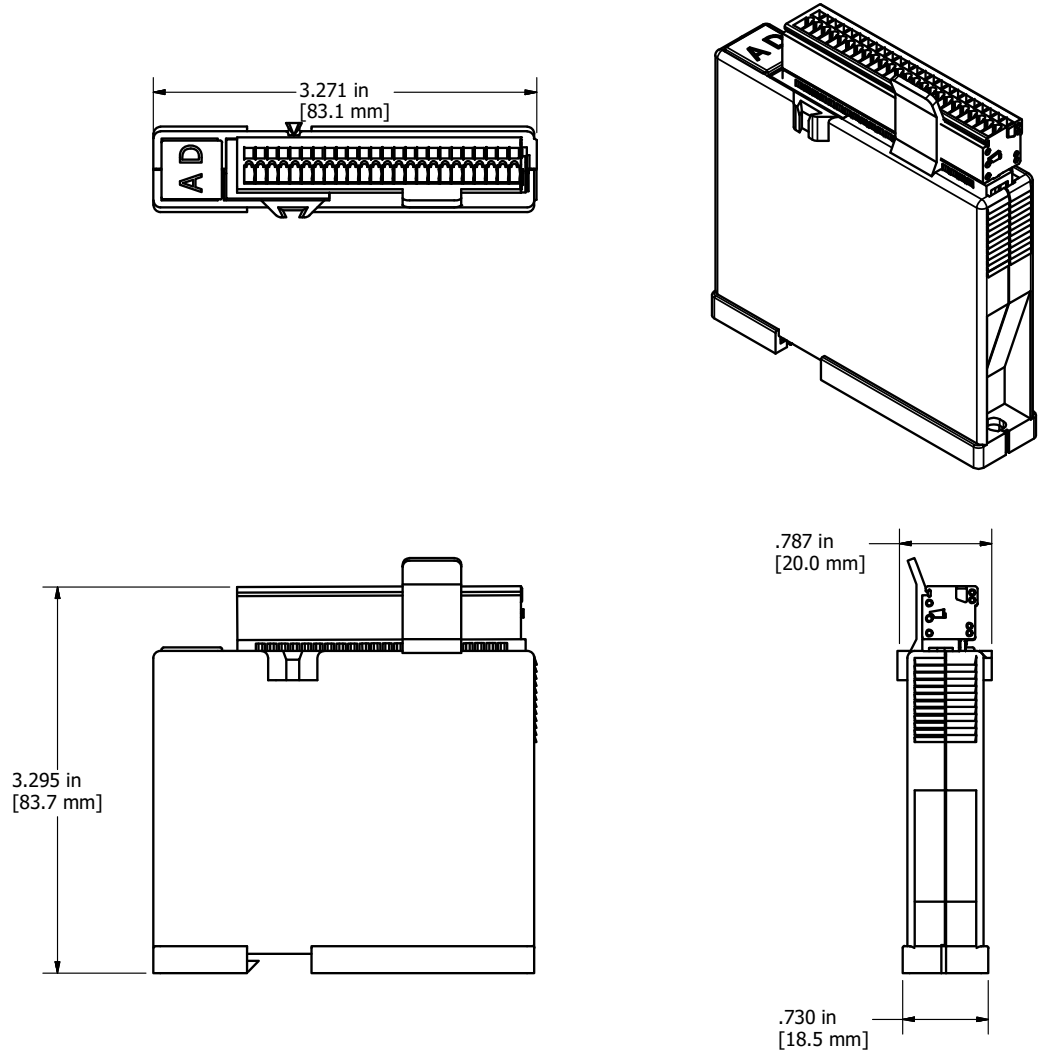

SNAP Analog Input Modules—32-Channel

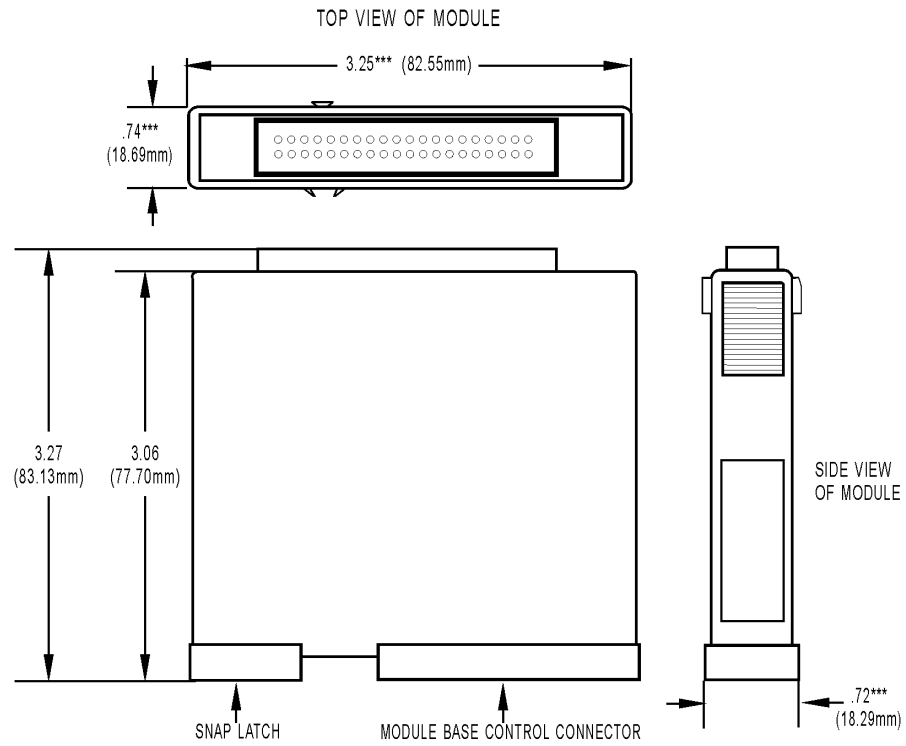

TOLERANCES LEGEND
 * +/- .010" ** +/- .020"
 *** +/- .030" **** +/- .060"
 NO * REFERENCE ONLY

SNAP Isolated Analog Input Modules—Most Modules

For SNAP-AITM-i and SNAP-AITM2-i, see [page 170](#).

For SNAP-AITM-4i, see [page 171](#).

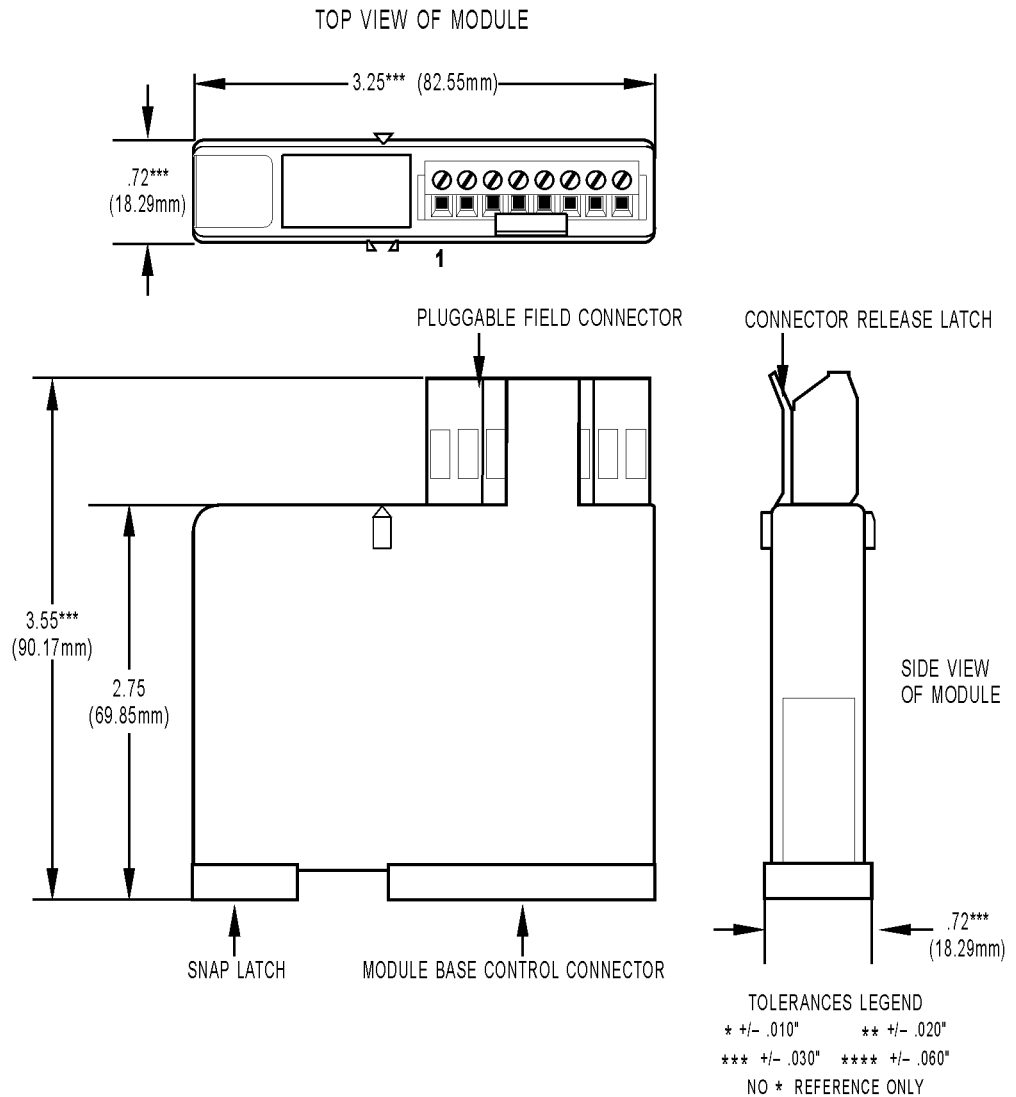

SNAP Isolated Analog Input Modules—SNAP-AITM-i and SNAP-AITM2-i

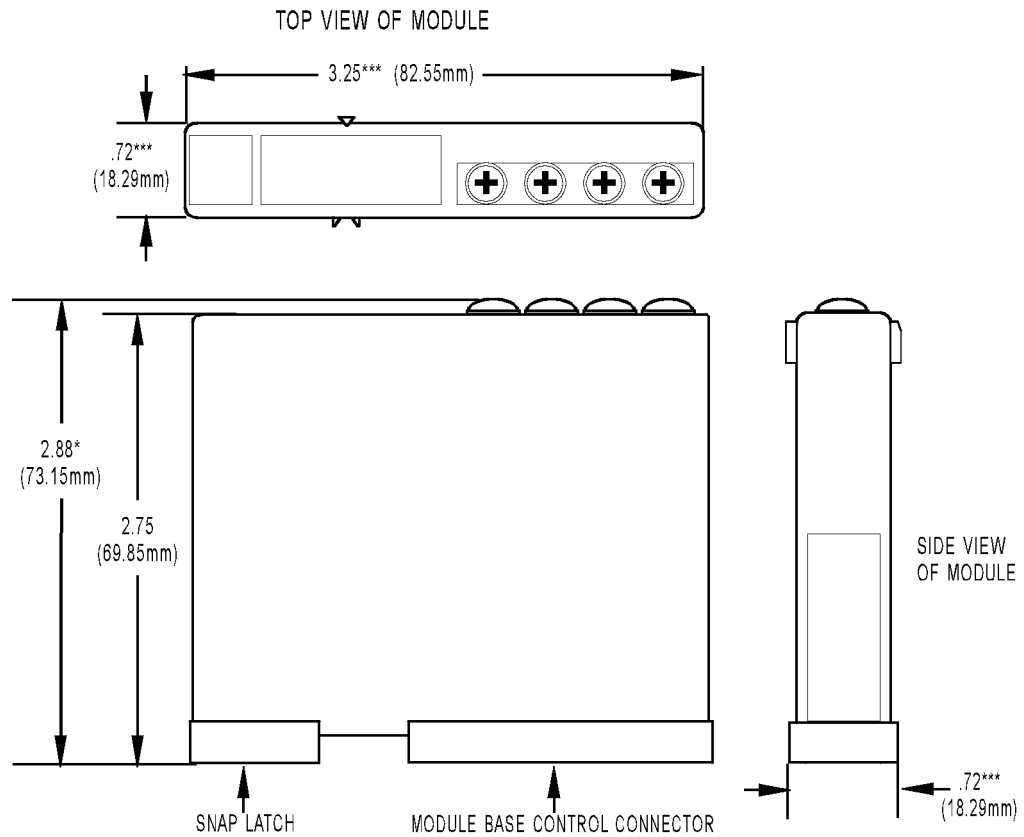

TOLERANCES LEGEND
 * +/- .010" ** +/- .020"
 *** +/- .030" **** +/- .060"
 NO * REFERENCE ONLY

SNAP Analog Input Modules—SNAP-AITM-4i

TOP VIEW OF MODULE

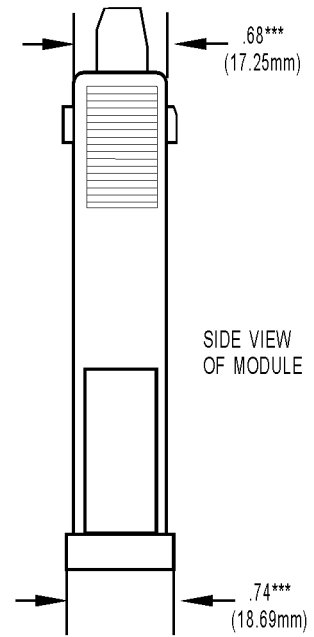
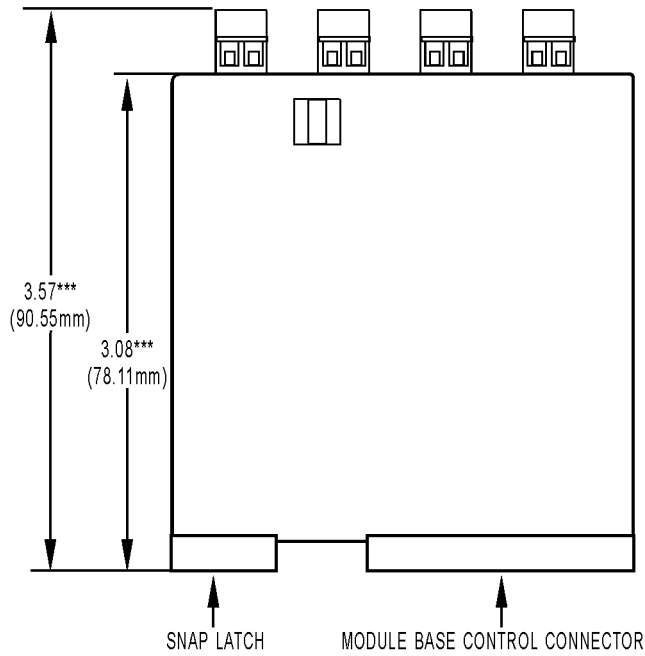
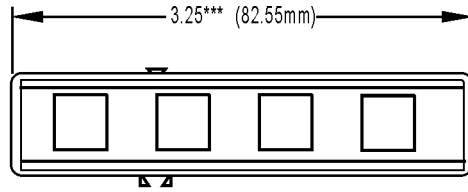

TOLERANCES LEGEND

- * +/- .010"
- ** +/- .020"
- *** +/- .030"
- **** +/- .060"
- NO * REFERENCE ONLY

SNAP Analog Output Modules—All modules except SNAP-AOA-23-iSRC, SNAP-AOA-23-iSRC-FM, and SNAP-AOVA-8

Note: The SNAP-AOD-29 time-proportional output (TPO) module has integral LEDs for monitoring and troubleshooting the module's outputs and inhibit inputs.

TOP VIEW OF MODULE

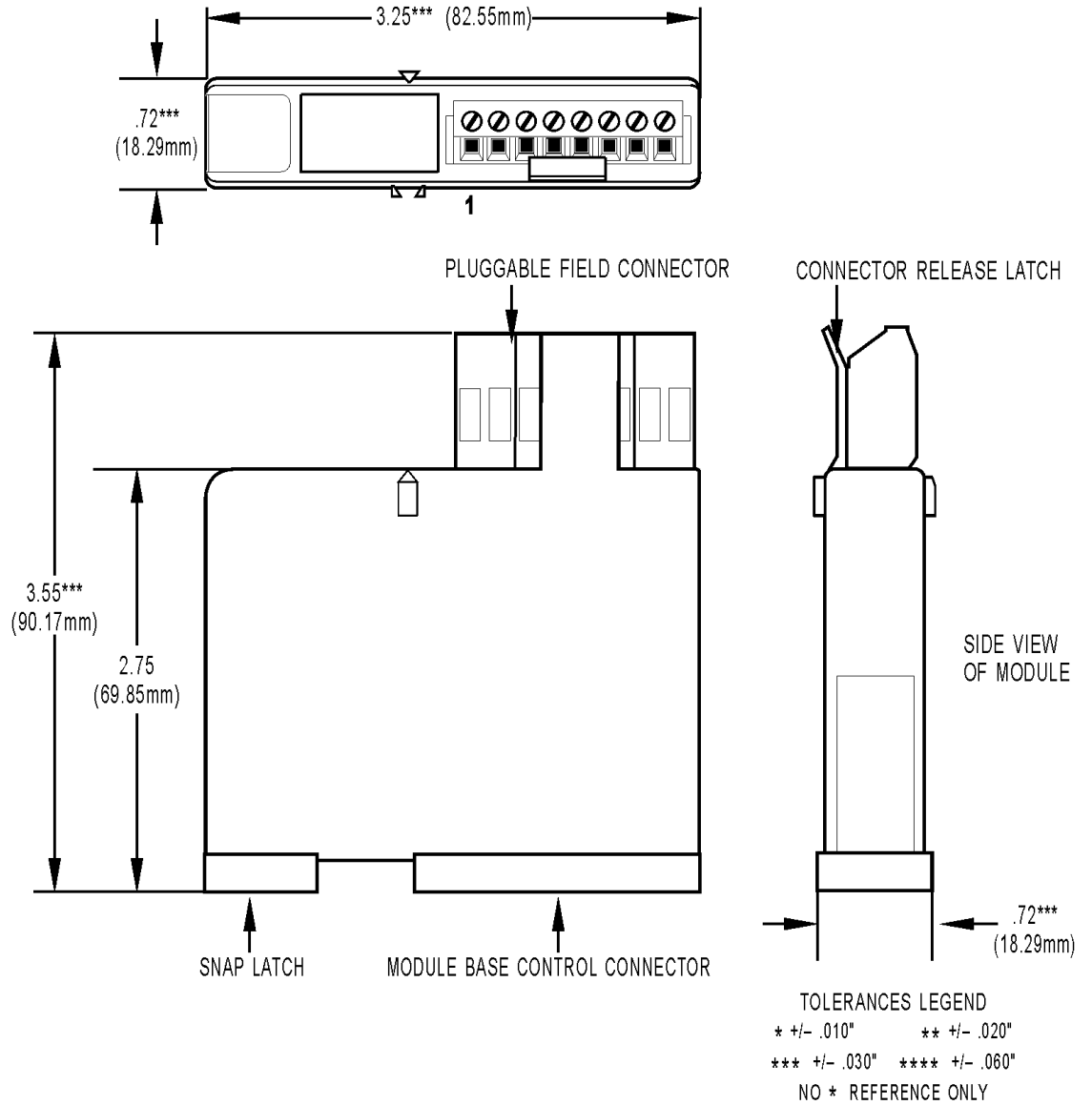

SNAP Analog Output Modules—SNAP-AOA-23-iSRC and SNAP-AOA-23-iSRC-FM only

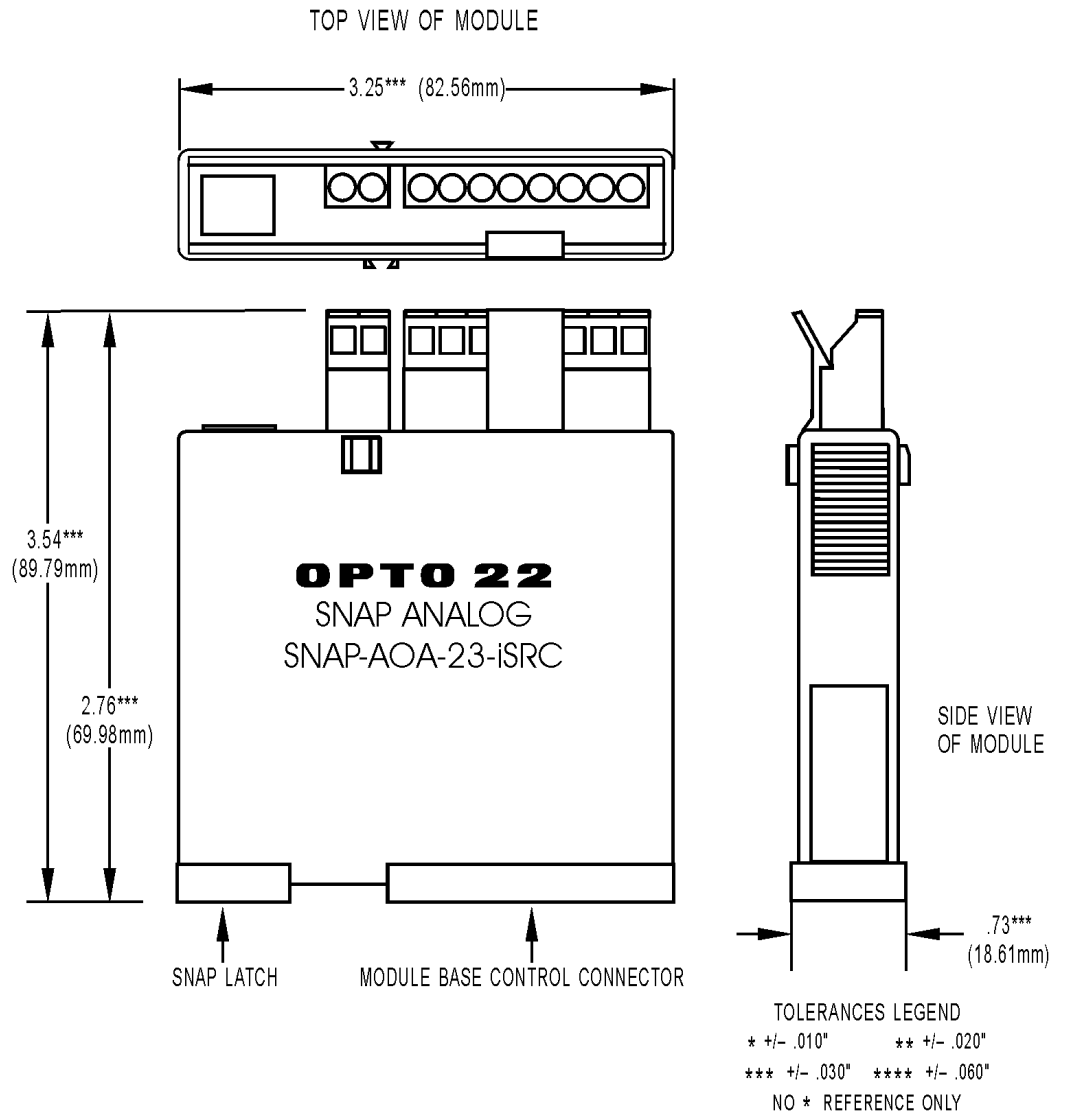

SNAP Analog Output Modules—SNAP-AOVA-8 only

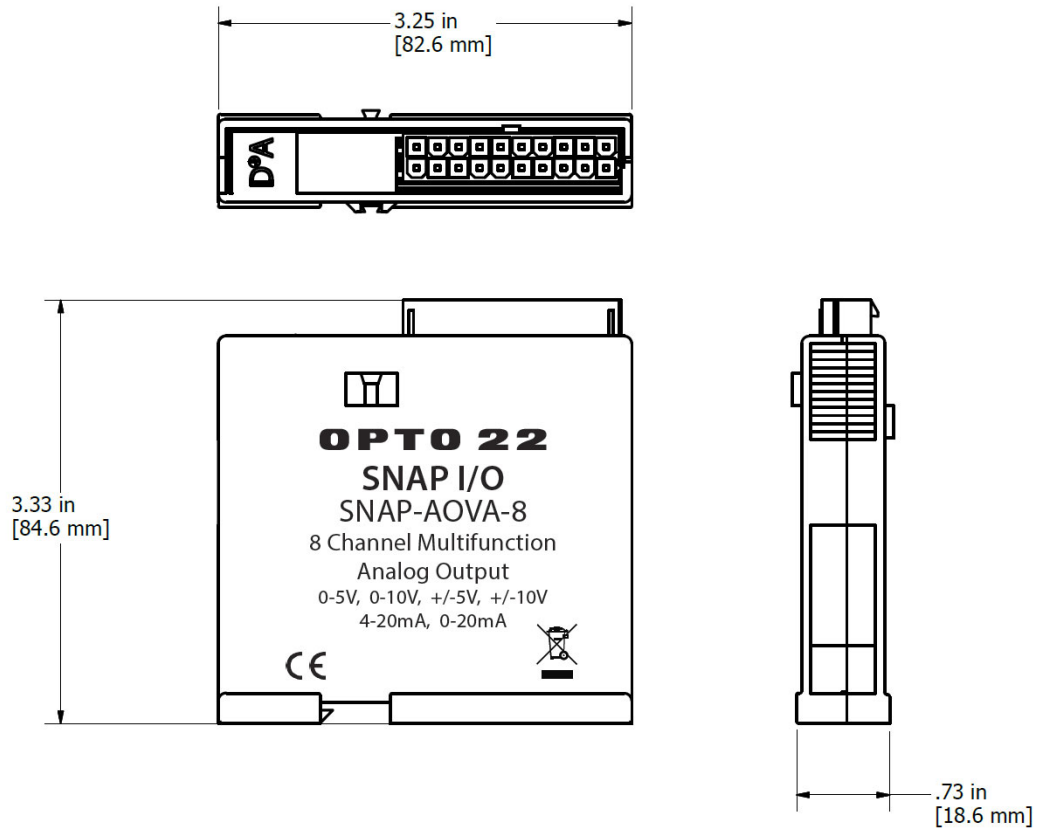

SNAP SERIAL MODULES

SNAP-SCM-232

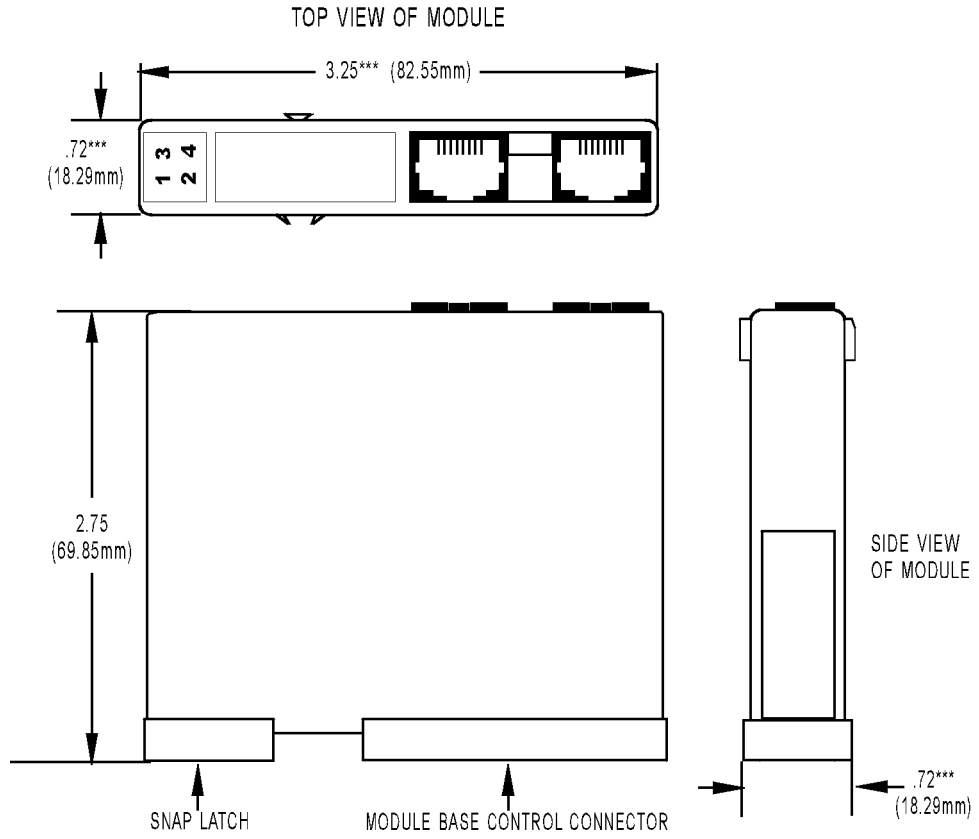

TOLERANCES LEGEND
* +/- .010" ** +/- .020"
*** +/- .030" **** +/- .060"
NO * REFERENCE ONLY

SNAP-SCM-485-422

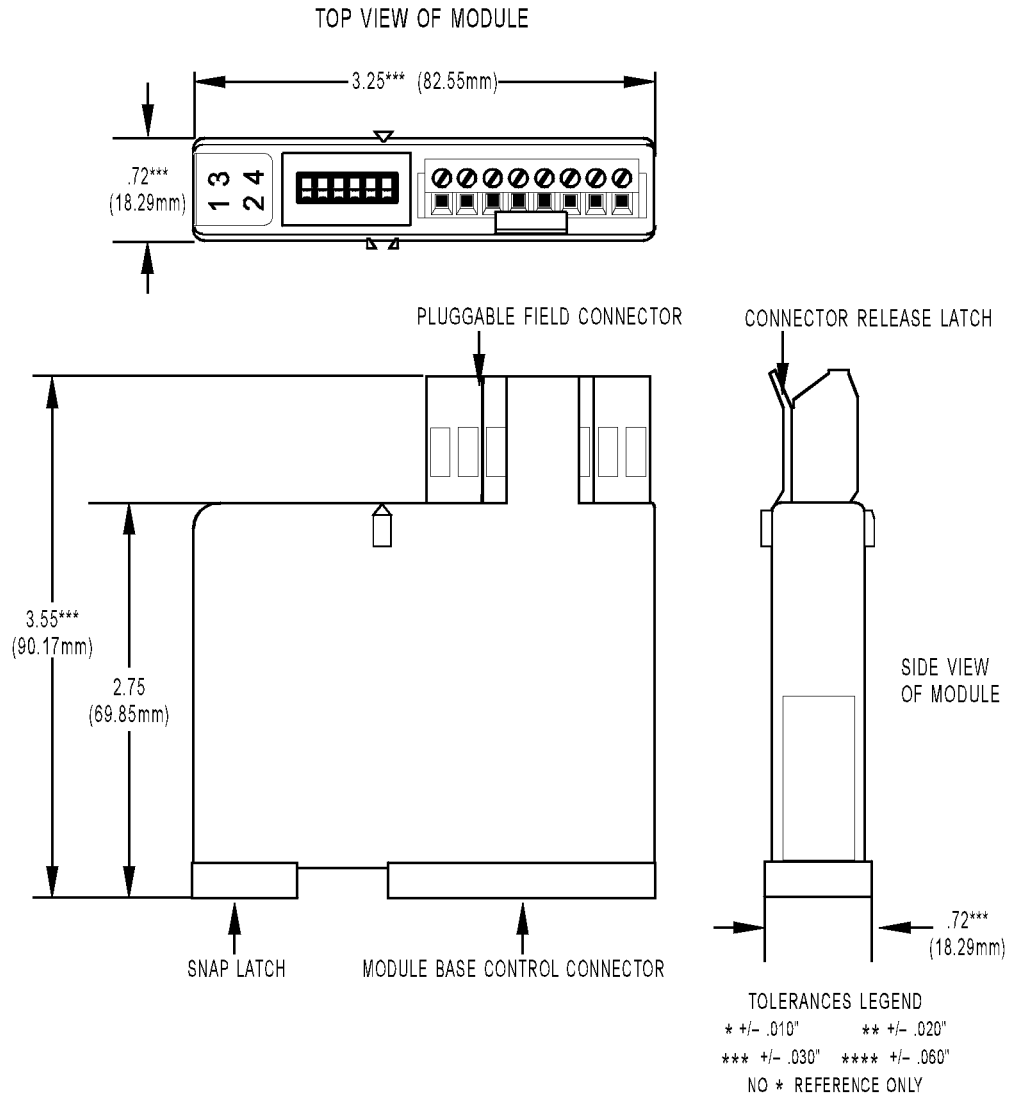

SNAP-SCM-ST2 and SNAP-SCM-CAN2B

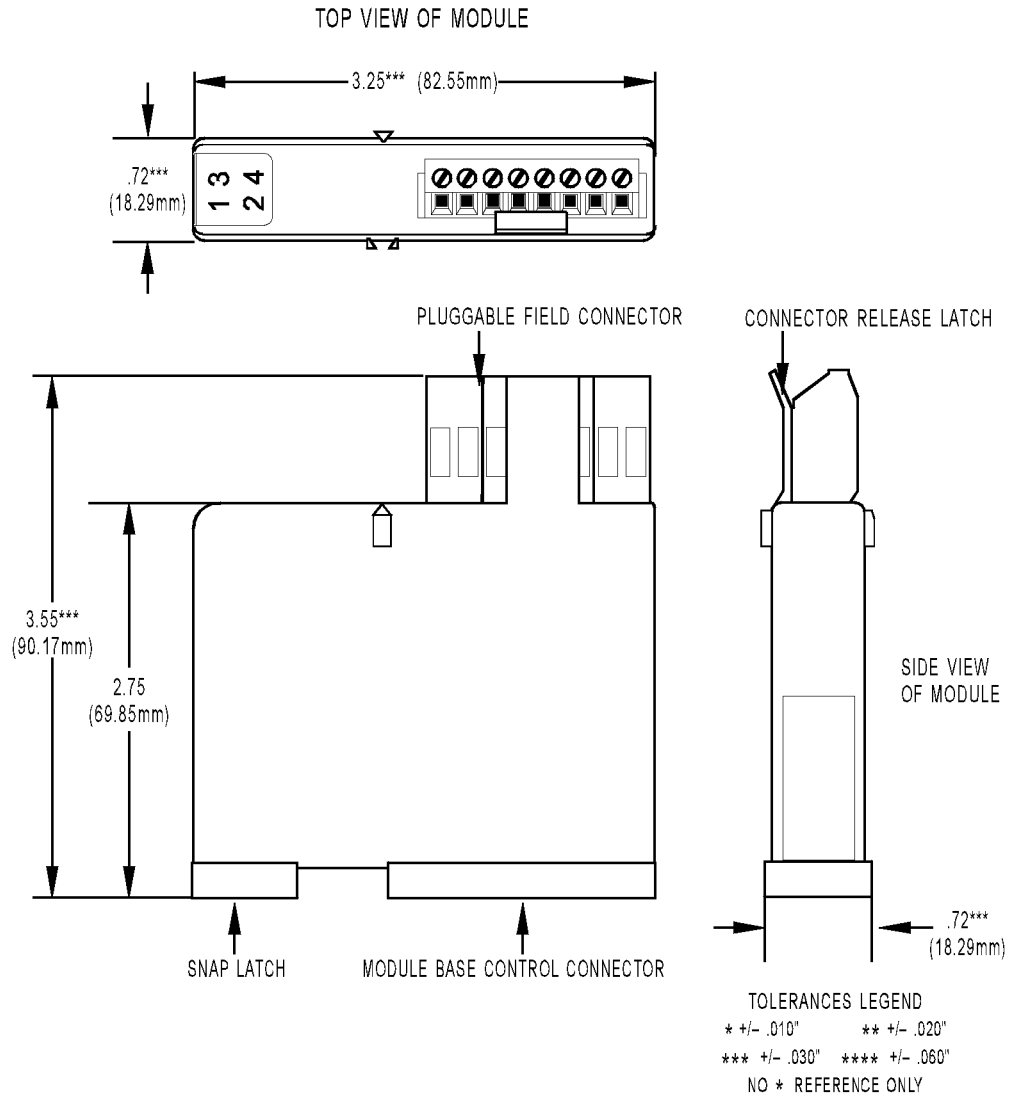

SNAP BREAKOUT BOARDS AND RACKS DIAGRAMS

SNAP-IDC-HDB Breakout Rack

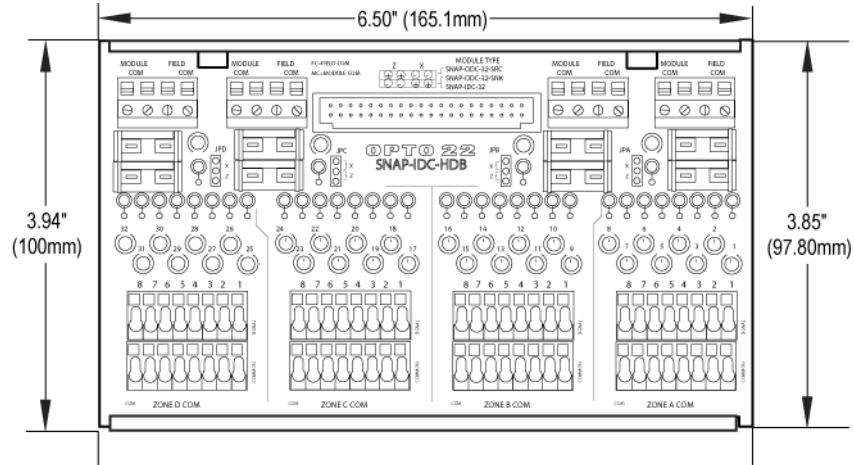

SNAP-ODC-HDB Breakout Rack

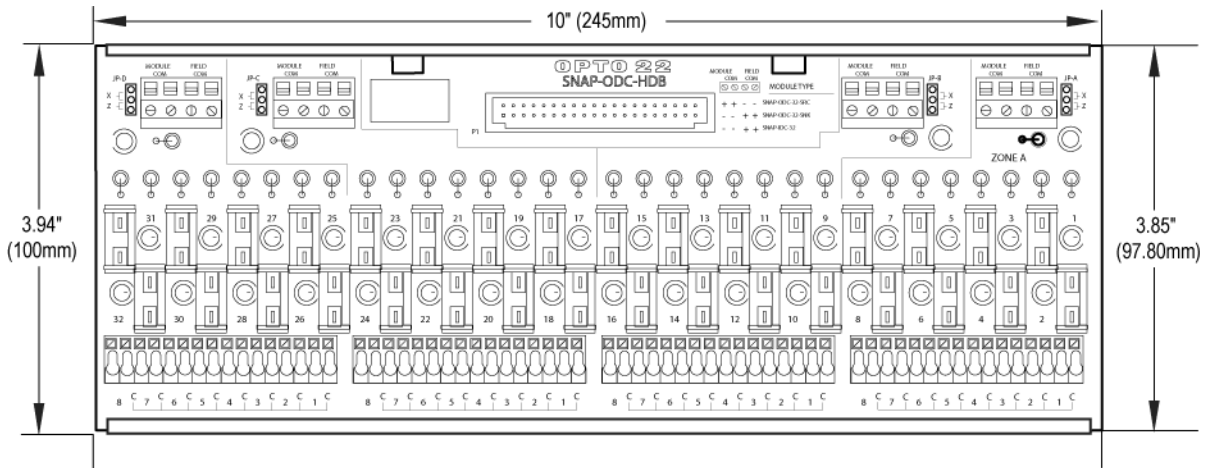

SNAP-UDC-HDB Breakout Rack

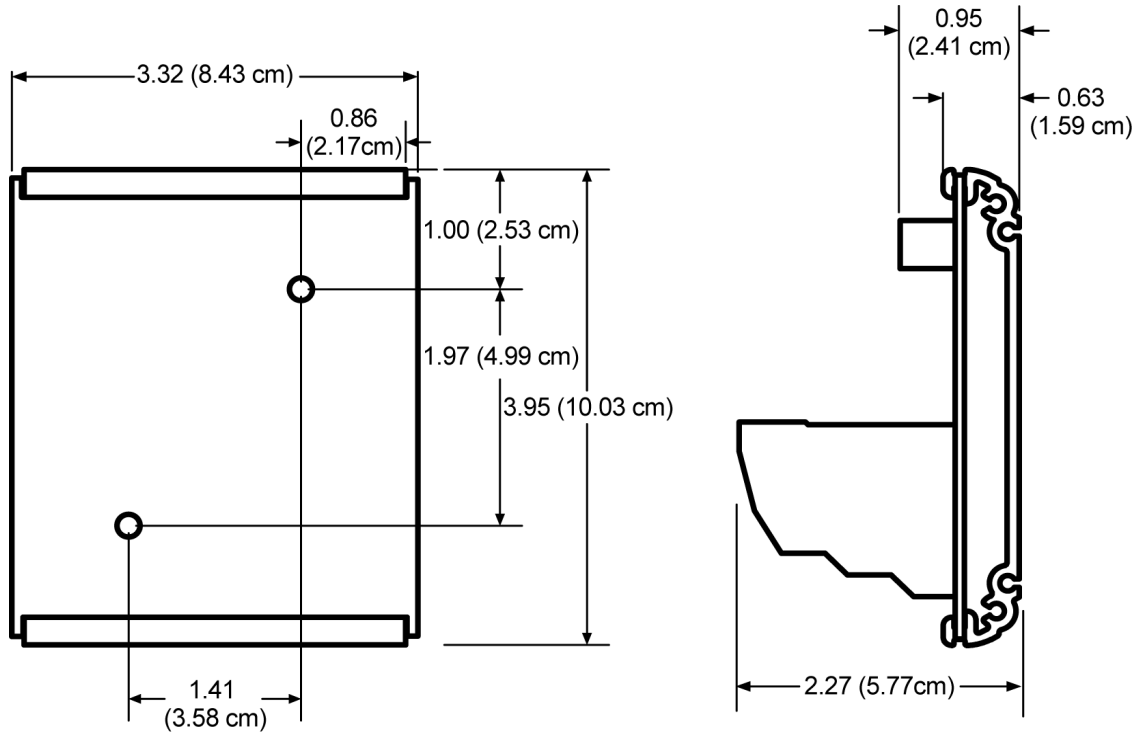

SNAP-UDC-HDB-G4 Breakout Rack

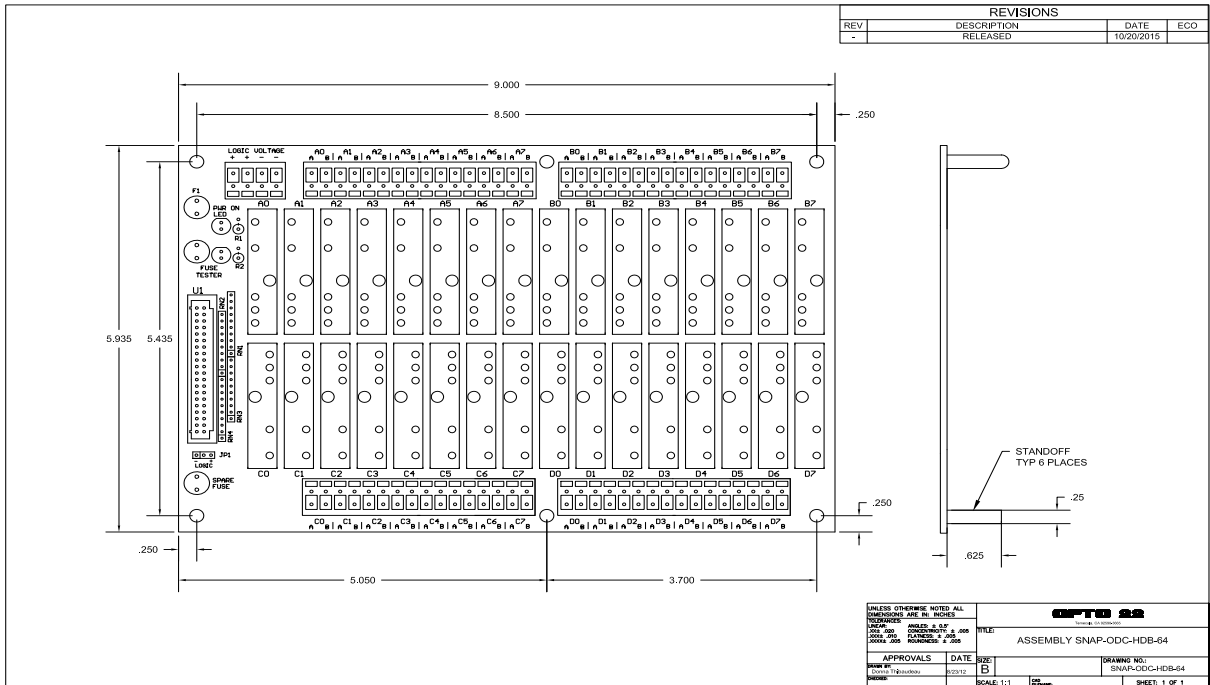

SNAP-AIMA-HDB Breakout Rack

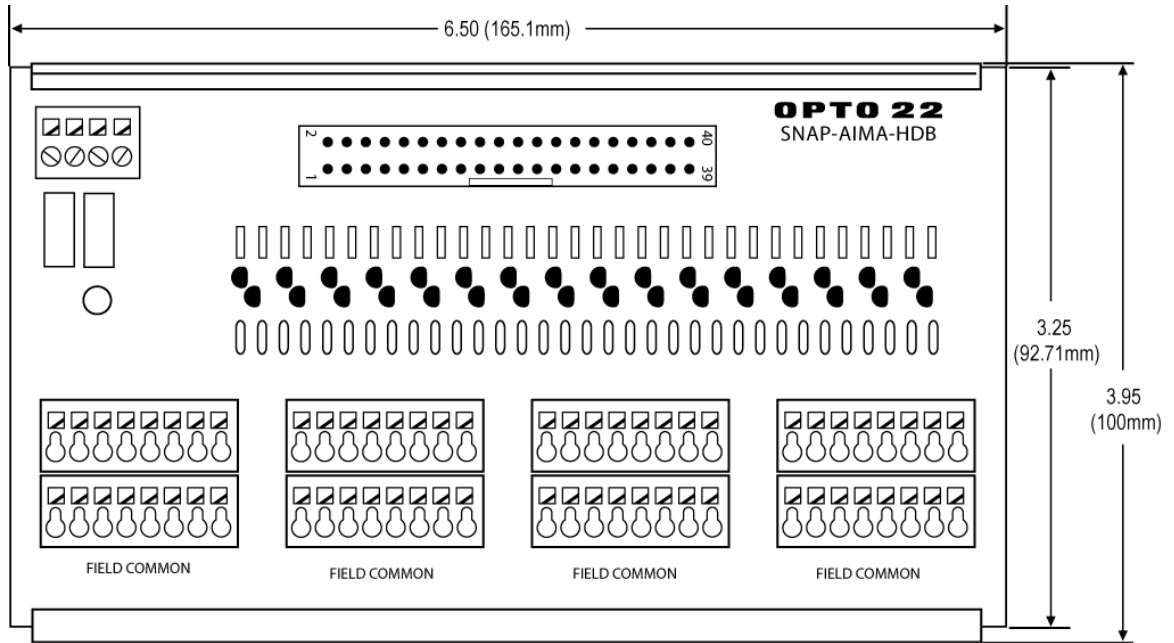

SNAP-AIV-HDB Breakout Rack

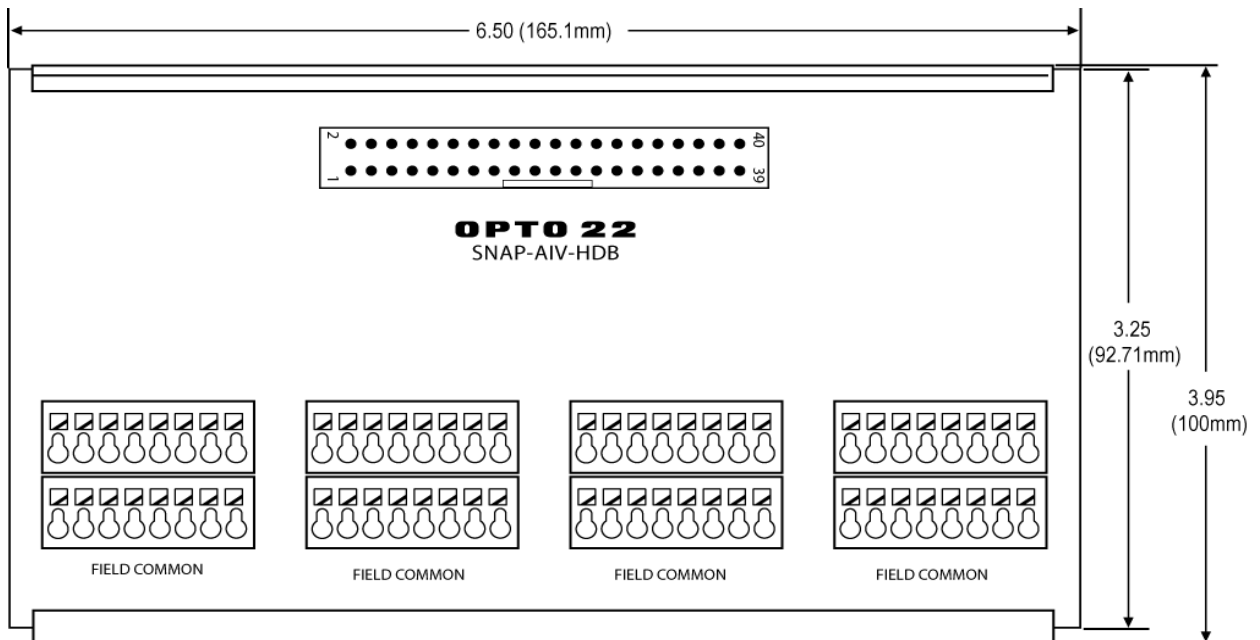

SNAP-TEX-32 Breakout Board

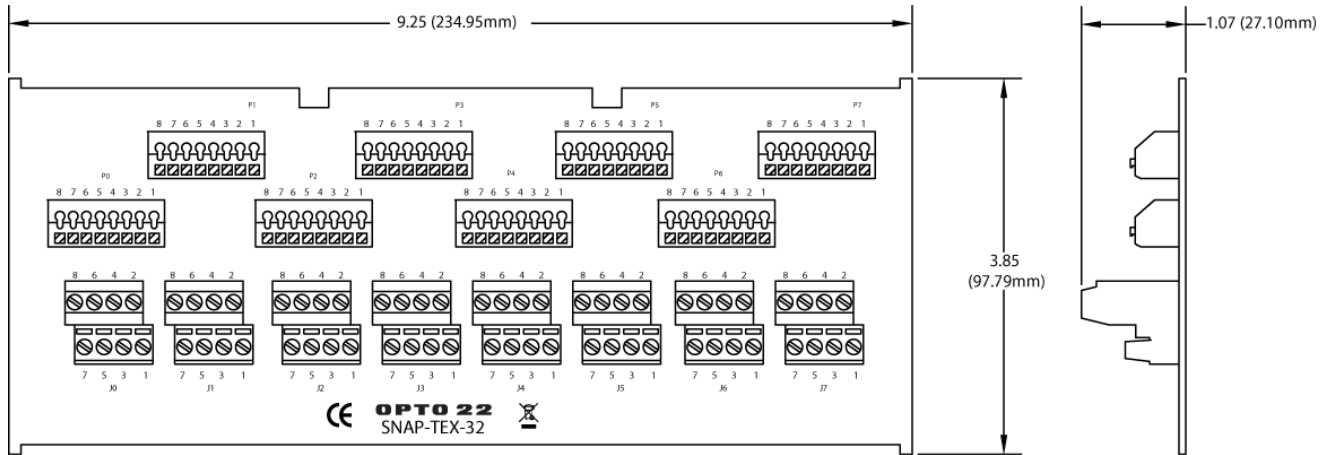

Index

A

- adding
 - database communication, 9
 - distributed I/O, 4
 - HMI seats, 5
 - large numbers of I/O, 6
 - OPC communication, 9
 - redundant network links, 10, 46
 - serial distributed I/O, 8
 - serial mistic I/O, 11, 51
- Allen-Bradley, 9, 49
- analog input modules
 - comparison, 30
 - dimensions, 163, 169
 - power requirements, 35
 - Q&A, 32
 - resolution, 32
 - specifications, 116
 - wiring, 74
 - wiring to field devices, 38, 39
- analog output modules
 - comparison, 32
 - dimensions, 172
 - power requirements, 35
 - Q&A, 32
 - resolution, 32
 - specifications, 136
 - wiring, 91
 - wiring to field devices, 38
- API, 2
- application program interface, 2

B

- baud rate, 56
- brains
 - choosing, 23
 - comparison chart, 23

- dimensions, 153
- installing, 55
- network interfaces, 42
- power requirements, 34
- serial networking, 56
- breakout boards, 36
 - dimensions, 178, 179
 - specifications, 145
- building a SNAP PAC System, 18
- buying SNAP PAC System components, 14

C

- cable specifications, 148
- cables, 36
- channel-to-channel isolation, 26
- choosing
 - brains, 23
 - controllers, 21
 - I/O, 26
 - mounting racks, 33
 - power supplies, 33
 - software, 19
- communicating
 - with Allen-Bradley systems, 9, 49
 - with databases, 9
 - with Modbus systems, 9, 48
 - with OPC clients, 9
 - with remote host, 50
 - with serial devices, 50
 - with serial I/O, 50
 - with serial mistic I/O units, 51
- comparing
 - analog input modules, 30
 - analog output modules, 32
 - brains, 23
 - controllers, 23
 - digital input modules, 27
 - digital output modules, 27

- serial modules, 33
- comparison chart
 - analog input modules, 30
 - analog output modules, 32
 - controllers and brains, 23
 - digital input modules, 27
 - digital output modules, 27
 - PAC Project Basic and Professional, 19
- compatibility chart
 - analog I/O, breakout boards, cables, 38, 39
 - digital I/O, breakout boards, cables, 37
 - DIN-rail adapters, 40
 - HDD I/O, breakout boards, cables, 39
- connecting to brain
 - serially, 56
- contact information, 14
- controller area network (CAN) module
 - dimensions, 177
 - specifications, 144
 - wiring, 98
- controllers
 - choosing, 21
 - comparison chart, 23
 - dimensions, 150, 151
 - installing, 53
 - mounting on DIN rail, 40
 - network interfaces, 42
 - power requirements, 34
- current loop power supply, wiring, 36, 59

D

- data sheets, 12
- database, exchanging data with, 9
- digital input modules
 - comparison, 27
 - dimensions, 156, 161
 - power requirements, 35
 - Q&A, 29
 - specifications, 100
 - wiring 4-channel modules, 61
 - wiring high-density digital modules, 70
 - wiring to field devices, 37, 39
- digital output modules
 - comparison, 27
 - dimensions, 158, 161
 - power requirements, 35
 - Q&A, 29
 - specifications, 106
 - wiring 4-channel digital modules, 63
 - wiring high-density modules, 70
 - wiring to field devices, 37, 39

- dimensional diagrams
 - analog input modules, 163
 - analog output modules, 172
 - brains, 153
 - controllers, 150, 151
 - digital input modules, 156
 - digital output modules, 158
 - high-density digital modules, 161
 - isolated analog input modules, 169
 - power supplies, 154
 - serial modules, 175
- DIN-rail mounting, 40
- distributed I/O, adding, 4
- documents for the SNAP PAC System, 12

E

- Ethernet
 - networking options, 46
 - redundant links, 46
 - segmenting network, 48
 - standard network usage, 46
- Ethernet brains, 23
 - network interfaces, 45
- EtherNet/IP, 9, 49
- expanding your system, 4

F

- FactoryFloor, 11
- field wiring, 36

G

- groov View, 5
- ground loop currents, 26

H

- hardware
 - data sheets, 12
 - user's guides, 13
- help
 - product support, 14
 - sales, 14
- high-density digital modules
 - breakout boards, 146, 147
 - dimensions, 161
 - power requirements, 35
 - specifications, 105, 106, 114
 - wiring, 68, 70
 - wiring connector, 70
 - wiring to field devices, 39

- HMI, 2
 - adding seats, 5
 - mobile, 5
- HTTP/HTTPS, 2

I

- I/O modules
 - 4-channel digital input, 61
 - 4-channel digital output, 63
 - analog input, 74
 - analog output, 91
 - choosing, 26
 - high-density digital, 70
 - installing, 54
 - power requirements, 35
 - removing, 55
 - serial, 96
 - wiring to field devices, 37
- I/O mounting racks, 33, 40
- I/O, adding large numbers, 6
- IGMP snooping, 49
- installing
 - brains, 55
 - controllers, 53
 - I/O modules, 54
 - on DIN rail, 40
 - R-series controllers, 55
- Internet of Things, 2
- IoT, 2
- isolation, 26

L

- LEDs
 - SNAP PAC EB brains, 45
 - SNAP PAC R-series controller, 44
 - SNAP PAC SB brains, 45
 - SNAP-PAC-S1 controller, 42
 - SNAP-PAC-S2 controller, 43
- legacy hardware, integrating, 11, 51
- loop power supply, 36, 59

M

- mechanical power relay output modules
 - dimensions, 160
 - specifications, 115
 - wiring, 66, 67
- mistic I/O, adding to system, 11, 51
- mobile devices, 5
- Modbus, 9, 48
 - communication diagram, 49

- modem communication, 50
- modules
 - analog input, 30, 116, 163
 - analog output, 32, 136, 172
 - digital input, 27, 100, 156
 - digital output, 27, 106, 158
 - serial, 33, 143, 175
- mounting racks, 33, 40

N

- network
 - options for Ethernet, 46
 - redundant links, 10, 46
 - segmenting, 48
 - serial, 56
 - serial options, 50
- network interfaces
 - SNAP PAC EB brains, 45
 - SNAP PAC R-series controllers, 44
 - SNAP PAC SB brains, 45
 - SNAP-PAC-S1 controller, 42
 - SNAP-PAC-S2 controller, 43

O

- old hardware, updating, 11
- OPC clients, communicating with, 9
- operator interface, 2, 5
 - mobile, 5
- optical isolation, 26
- OptoControl, 11
- OptoDataLink, 9, 19
- OptoDisplay, 11
- OptoOPCServer, 9, 19

P

- PAC, 21
- PAC Control, 19
- PAC Display, 19
- PAC Manager, 19
- PAC Project software, 19
 - comparison chart, 19
- power supply
 - current loop, 36, 59
 - determining requirements, 34
 - dimensions, 154
 - mounting on DIN rail, 40
 - primary supply, 33, 59
- PPP, 50
- processor power requirements, 34
- product data sheets, 12

- product support, 14
- programmable automation controllers, 21
- purchasing SNAP PAC System components, 14

R

- racks for mounting I/O, 33
- redundant network links, 10, 46
- remote host, communicating with, 50
- removing I/O modules, 55
- REST, 2
- R-series controller
 - description, 22
 - dimensions, 152
 - installing, 55
 - network interfaces and ports, 44
- RSLogix, 9, 49

S

- sales, 14
- segmenting network, 48
- serial and Ethernet I/O, combining, 8
- serial brains, 23
 - dimensions, 153
 - installation, 56
 - networking, 56
- serial devices, communicating with, 50
- serial I/O units, adding to system, 50, 51
- serial modules
 - comparison, 33
 - dimensions, 175
 - power requirements, 35
 - specifications, 143
 - wiring, 96
- serial network, 56
 - options, 50
- serial ports, 50
 - on controllers, 50
 - SB brains, 45
 - SNAP PAC R-series controller, 44
 - SNAP-PAC-S1 controller, 42
 - SNAP-PAC-S2 controller, 43
- server, 2
- smartphone, 5
- SNAP PAC brains
 - comparison chart, 23
 - dimensions, 153
- SNAP PAC EB brains
 - installing, 55
 - network interfaces, 45
- SNAP PAC R-series controller
 - description, 22

- installing, 55
- network interfaces and ports, 44

- SNAP PAC SB brains
 - dimensions, 153
 - installing, 55
 - network interfaces, 45
 - networking, 56
- SNAP PAC S-series controller
 - description, 22
 - network interfaces and ports, 42, 43
- SNAP PAC System
 - brains, 23
 - building, 18
 - components, 18
 - controllers, 21
 - data sheets, 12
 - definition, 1
 - documents, 12
 - expanding, 4
 - I/O, 26
 - mounting racks, 33
 - power supplies, 33
 - software, 19
 - user's guides, 13
- SNAP TEX, 36
- SNAP-AIARMS, 74, 116
- SNAP-AIARMS-i, 74, 116
- SNAP-AICTD, 76, 118
- SNAP-AICTD-4, 76, 118
- SNAP-AICTD-8, 77, 118, 165
- SNAP-AILC, 77, 117
- SNAP-AILC-2, 77, 117
- SNAP-AIMA, 78, 119
- SNAP-AIMA2-i, 80, 120
- SNAP-AIMA-32, 81, 89, 90, 120, 168
- SNAP-AIMA-4, 78, 119
- SNAP-AIMA-8, 79, 119, 165
- SNAP-AIMA-HDB, 180
- SNAP-AIMA-i, 80, 121
- SNAP-AIMA-iSRC, 82, 122
- SNAP-AIMA-iSRC-FM, 82, 122
- SNAP-AIMV2-4, 84
- SNAP-AIMV-4, 84, 124
- SNAP-AIR400K-8, 82, 127, 166, 167
- SNAP-AIR40K-4, 82, 128
- SNAP-AIRATE, 83, 123
- SNAP-AIRATE-HFi, 83, 123
- SNAP-AIRTD, 86, 125
- SNAP-AIRTD-10, 86, 125
- SNAP-AIRTD-1K, 86, 125
- SNAP-AIRTD-8U, 86, 126
- SNAP-AITM, 84, 128
- SNAP-AITM-2, 84, 129

SNAP-AITM2-i, 85, 129, 170
 SNAP-AITM-4i, 85, 129, 171
 SNAP-AITM-8, 84, 132, 164
 SNAP-AITM-8-FM, 132
 SNAP-AITM-i, 85, 131, 170
 SNAP-AIV, 87, 133
 SNAP-AIV2-i, 88, 133
 SNAP-AIV-32, 89, 168
 SNAP-AIV-4, 87, 88, 133
 SNAP-AIV-8, 134, 165
 SNAP-AIV-HDB, 180
 SNAP-AIV-i, 88, 130
 SNAP-AIVRMS, 75, 135
 SNAP-AIVRMS-i, 75, 135
 SNAP-AOA-23, 92, 136
 SNAP-AOA-23-iSRC, 92, 137, 173
 SNAP-AOA-23-iSRC-FM, 137, 173
 SNAP-AOA-28, 93, 138
 SNAP-AOA-3, 91, 136
 SNAP-AOD-29, 95, 139
 SNAP-AOD-29-HFi, 95, 139
 SNAP-AOV-25, 93, 140
 SNAP-AOV-27, 93, 141
 SNAP-AOV-5, 91, 140
 SNAP-AOVA-8, 94, 174
 SNAP-HD-ACF6, 148
 SNAP-HD-BF6, 148
 SNAP-HD-CBF6, 70, 148
 SNAP-IAC-16, 68, 106
 SNAP-IAC5, 61, 100
 SNAP-IAC5A, 61, 100
 SNAP-IAC5MA, 61, 100
 SNAP-IDC-16, 68, 106
 SNAP-IDC-32, 71, 105
 SNAP-IDC-32D, 72, 105
 SNAP-IDC-32DN, 72, 105
 SNAP-IDC-32-FM, 71, 105
 SNAP-IDC-32N, 71, 105
 SNAP-IDC5, 61, 102
 SNAP-IDC5D, 61, 102
 SNAP-IDC5-FAST, 61, 103
 SNAP-IDC5-FAST-A, 61, 103
 SNAP-IDC5FM, 61, 101
 SNAP-IDC5G, 61
 SNAP-IDC5HT, 61, 102
 SNAP-IDC5MA, 61, 103
 SNAP-IDC5Q, 62, 104
 SNAP-IDC5-SW, 61, 104
 SNAP-IDC5-SW-NC, 61, 104
 SNAP-IDC-HDB, 146, 178
 SNAP-IDC-HT-16, 68, 106
 SNAP-OAC5, 63, 107
 SNAP-OAC5-i, 63, 107
 SNAP-OAC5MA, 63, 107
 SNAP-ODC-32-SNK, 73, 114
 SNAP-ODC-32-SRC, 73, 114
 SNAP-ODC5A-i, 66, 113
 SNAP-ODC5ASNK, 64, 113
 SNAP-ODC5-i, 66, 113
 SNAP-ODC5-iFM, 66, 112
 SNAP-ODC5MA, 65, 113
 SNAP-ODC5R, 65, 108, 110
 SNAP-ODC5R5, 65, 108, 110
 SNAP-ODC5RFM, 65, 111
 SNAP-ODC5SNK, 64, 108
 SNAP-ODC5SNKFM, 64, 109
 SNAP-ODC5SRC, 64, 108
 SNAP-ODC5SRCFM, 64, 109
 SNAP-ODC-HDB, 146, 178
 SNAP-OMR6-C, 67, 115, 160
 SNAP-OMR6T-C, 66, 115, 160
 SNAP-PAC-EB1, 23
 SNAP-PAC-EB2, 23
 SNAP-PAC-R1, 152
 SNAP-PAC-R1-FM, 152
 SNAP-PAC-R2, 152
 SNAP-PAC-S1, 150
 SNAP-PAC-S2, 151
 SNAP-PAC-SB1, 23, 57, 58, 153
 SNAP-PAC-SB2, 23, 57, 58, 153
 SNAP-PS24, 154
 SNAP-PS24U, 155
 SNAP-PS5, 154
 SNAP-PS5-24DC, 154
 SNAP-PS5U, 155
 SNAP-SCM-232, 96, 143, 175
 SNAP-SCM-485, 176
 SNAP-SCM-485-422, 97, 143
 SNAP-SCM-CAN2B, 98, 144, 177
 SNAP-SCM-ST2, 98, 143, 177
 SNAP-TEX-32, 181
 SNAP-TEX-CBE6, 148
 SNAP-TEX-CBO6, 148
 SNAP-TEX-CBS6, 148
 SNAP-UDC-HDB, 147, 179
 SNAP-UDC-HDB-G4, 147, 179
 SoftPAC, 19, 22
 software, 19
 specifications
 analog input modules, 116
 analog output modules, 136
 breakout boards, 145
 cables, 148
 digital input modules, 100
 digital output modules, 106
 high-density digital input modules, 105, 106

- high-density digital output modules, 114
- serial modules, 143
- S-series controller
 - description, 22
 - dimensions, 150, 151
 - network interfaces and ports, 42, 43
- stepper motor pulse and direction module
 - dimensions, 177
 - specifications, 143
 - wiring, 98

T

- tablet, 5
- technical support, 14
- termination, 56
- transformer isolation, 26
- troubleshooting
 - product support, 14

U

- updating older systems, 11
- user guides for SNAP PAC System, 13

W

- wiring
 - 4-channel digital input modules, 61
 - 4-channel digital output modules, 63
 - analog input modules, 74
 - analog output modules, 91
 - breakout boards, 145
 - high-density digital modules, 68
 - primary power supply, 59
 - serial modules, 96
 - to field devices, 36