

SNAP TEX CABLES AND BREAKOUT BOARDS

Features

- > Extend the terminals on your SNAP I/O modules for easier, cleaner wiring to field devices.
- > Six-foot (1.8 meter) wiring cables plug into tops of I/O modules for quick replacement.
- > Breakout boards offer options such as fusing, power to loads, and mechanical relays.
- > Integrate older G4 digital I/O with SNAP PAC I/O.



SNAP TEX Family

SNAP TEX cables provide convenient connections from I/O modules to field wiring. Most cables are designed to connect to breakout boards; some cables have flying leads for direct connection to field devices.

SNAP TEX breakout boards move terminals away from the crowded rack area for easier installation and maintenance. Most boards can be panel mounted or DIN-rail mounted (see [page 10](#)). See compatibility tables starting on [page 2](#).

DESCRIPTION

SNAP TEX cables and breakout boards are part of the SNAP TEX family of wiring and mounting accessories. (See form 1772 for accessories not covered in this data sheet.) These cables and boards save time and expense during installation, maintenance, and debugging by reducing the time and effort required to wire field devices to SNAP I/O modules.

Choose the cables and breakout boards for your modules based on the table that starts on [page 2](#). Specifications and dimensions begin on [page 5](#) and wiring diagrams on [page 24](#). Assembly and installation steps are on [page 10](#).

Part Numbers

Part	Description
Cables	
SNAP-HD-20F6	6 ft. (1.8 m) wiring cable for SNAP-AOVA-8 module, with flying leads
SNAP-HD-ACF6	6 ft. (1.8 m) wiring harness assembly for SNAP 16-point digital modules; flying leads
SNAP-HD-BF6	6 ft. (1.8 m) wiring harness for 32-channel modules and breakout boards
SNAP-HD-CBF6	6 ft. (1.8 m) wiring harness for most 32-point modules, with flying leads
SNAP-HD-G4F6	6 ft. (1.8 m) header cable for SNAP-ODC-32-SNK and SNAP-IDC-32 digital modules and G4PB16H and G4PB16HC mounting racks. Also for SNAP-ODC-32-SRC when connecting to a SNAP-MR10-16C breakout board.
SNAP-HD-G4F6N	6 ft. (1.8 m) header cable for SNAP-IDC-32N digital modules and G4PB16H and G4PB16HC mounting racks
SNAP-TEX-CBE6	6 ft. (1.8 m), 8-wire cable for SNAP I/O modules. Even terminals commoned, flying leads.
SNAP-TEX-CBO6	6 ft. (1.8 m), 8-wire cable for SNAP I/O modules. Odd terminals commoned, flying leads.
SNAP-TEX-CBS6	6 ft. (1.8 m), 8-wire cable for SNAP I/O modules. Straight-through; no common terminals. Flying leads.

Part Numbers (continued)

Part	Description
Breakout Boards	
SNAP-AIMA-HDB SNAP-AIMA-HDB-FM*	Breakout boards for SNAP-AIMA-32 and SNAP-AIMA-32-FM analog input modules
SNAP-AIV-HDB SNAP-AIV-HDB-FM*	Breakout boards for SNAP-AIV-32 and SNAP-AIV-32-FM analog modules
SNAP-IDC-HDB SNAP-IDC-HDB-FM*	Fused breakout board for SNAP 32-point digital input modules
SNAP-ODC-HDB SNAP-ODC-HDB-FM*	Fused breakout board for SNAP 32-point digital output modules
SNAP-UDC-HDB	Compact breakout board with spring clamps for SNAP 32-point digital modules
SNAP-UDC-HDB-G4	G4 I/O breakout board with spring clamps for one SNAP 32-point digital module
SNAP-TEX-FB16-H	16-point breakout board for SNAP I/O modules, with fuses, fuse-blown indicators & bussed power (120–240 V)
SNAP-TEX-FB16-L	16-point breakout board for SNAP I/O modules, with fuses, fuse-blown indicators & bussed power (12–24 V)
SNAP-TEX-MR10-16	Mechanical relay breakout board for one 16-point or four 4-point SNAP digital output modules.
SNAP-TEX-MR10-16C	Mechanical relay breakout board for one 16-point or four 4-point SNAP digital output modules, or connecting two boards to one 32-point digital module. Optional jumper straps.
SNAP-TEX-MR10-4	Mechanical relay breakout board for a 4-point SNAP digital output module
SNAP-TEX-32	32-point breakout board for SNAP I/O modules
* Factory Mutual approved	

MODULE, BREAKOUT BOARD, AND CABLE COMPATIBILITY CHARTS

Find your module in the left column. Choose the breakout board from the right columns. Compatible cables are shown in the table cells in the center.

4-Point Digital Modules

Module	Breakout Board		
	SNAP-TEX-32 **	SNAP-TEX-FB16-H SNAP-TEX-FB16-L	SNAP-TEX-MR10-4 SNAP-TEX-MR10-16 SNAP-TEX-MR10-16C
Digital input modules—4-point			
SNAP-IAC5 SNAP-IAC5A SNAP-IAC5AFM SNAP-IAC5FM SNAP-IAC5MA SNAP-IDC5MA	SNAP-TEX-CBS6 *	SNAP-TEX-CBS6 *	Not used for inputs
SNAP-IDC5 SNAP-IDC5-FAST-A SNAP-IDC5-HT SNAP-IDC5D SNAP-IDC5DFM SNAP-IDC5FAST SNAP-IDC5FM SNAP-IDC5G	SNAP-TEX-CBE6 SNAP-TEX-CBO6 SNAP-TEX-CBS6	SNAP-TEX-CBO6 SNAP-TEX-CBS6	Not used for inputs
SNAP-IDC5Q	SNAP-TEX-CBS6	Not used	Not used for inputs
SNAP-IDC5-SW SNAP-IDC5-SW-NC	SNAP-TEX-CBS6	Not used	Not used for inputs
Digital output modules—4-point			
SNAP-ODC5-I SNAP-ODC5-IFM SNAP-ODC5A-I SNAP-ODC5A-IFM SNAP-ODC5MA	SNAP-TEX-CBS6 *	SNAP-TEX-CBS6 *	SNAP-TEX-CBO6 SNAP-TEX-CBS6
SNAP-OAC5-I SNAP-OAC5-IFM SNAP-OAC5MA	SNAP-TEX-CBS6 *	SNAP-TEX-CBS6 *	Not used
SNAP-ODC5SRC SNAP-ODC5SRCFM	SNAP-TEX-CBO6 SNAP-TEX-CBS6	SNAP-TEX-CBO6 SNAP-TEX-CBS6	SNAP-TEX-CBO6 SNAP-TEX-CBS6
SNAP-OAC5 SNAP-OAC5FM SNAP-ODC5ASNK SNAP-ODC5R SNAP-ODC5R5 SNAP-ODC5R5FM SNAP-ODC5RFM SNAP-ODC5SNK SNAP-ODC5SNKFM	SNAP-TEX-CBE6 SNAP-TEX-CBO6 SNAP-TEX-CBS6	SNAP-TEX-CBO6 SNAP-TEX-CBS6	Not used
SNAP-OMR6T-C SNAP-OMR6-C	Not used	Not used	Not used

* This cable maintains channel-to-channel isolation on these modules. If channel-to-channel isolation is not important, you can also use the SNAP-TEX-CBO6 cable.

** The SNAP-TEX-32 can be used with digital outputs but has no fuses. SNAP-TEX-FB16 boards are preferable for digital outputs because they include fuses.

MODULE, BREAKOUT BOARD, AND CABLE COMPATIBILITY CHARTS (CONTINUED)

Find your module in the left column. Choose the breakout board from the right columns. Compatible cables are shown in the table cells in the center.

1-, 2-, and 4-Point Analog Modules

Module	Breakout Board		
	SNAP-TEX-32	SNAP-TEX-FB16-H SNAP-TEX-FB16-L	SNAP-TEX-MR10-4 SNAP-TEX-MR10-16 SNAP-TEX-MR10-16C
Analog input modules (not thermocouples)			
SNAP-AIARMS SNAP-AIARMS-i SNAP-AIARMS-i-FM SNAP-AICTD SNAP-AICTD-4 SNAP-AILC ^a SNAP-AILC-2 ^a SNAP-AIMA-i SNAP-AIMA-iSRC ^a SNAP-AIMA-iSRC-FM ^a SNAP-AIMA-iH SNAP-AIMA2-i	SNAP-AIRATE SNAP-AIRATE-HFi SNAP-AIRTD SNAP-AIRTD-10 SNAP-AIRTD-1K SNAP-AIV-72 SNAP-AIV-i SNAP-AIV2-i SNAP-AIVRMS SNAP-AIVRMS-i SNAP-AIVRMS-i-FM	SNAP-TEX-CBS6	Not used for analog modules
SNAP-AIMA SNAP-AIMA-4 SNAP-AIMV2-4 SNAP-AIMV-4	SNAP-AIR40K-4 SNAP-AIV SNAP-AIV-4	SNAP-TEX-CBE6 SNAP-TEX-CBS6	Not used for analog modules
SNAP-AIPM SNAP-AIPM-3 ^b SNAP-AIPM-3V SNAP-AITM ^c SNAP-AITM-i ^c	SNAP-AITM-2 ^c SNAP-AITM-4i ^c SNAP-AITM2-i ^c SNAP-pH/ORP	No cable available	Not used for analog modules
Analog output modules			
SNAP-AOA-23	SNAP-AOA-28	SNAP-TEX-CBE6 SNAP-TEX-CBS6	Not used for analog modules
SNAP-AOA-3	SNAP-AOV-5	SNAP-TEX-CBE6 SNAP-TEX-CBO6 SNAP-TEX-CBS6	Not used for analog modules
SNAP-AOV-25	SNAP-AOV-27	SNAP-TEX-CBO6	Not used for analog modules
SNAP-AOA-23-iH SNAP-AOA-23-iSRC ^a SNAP-AOA-23-iSRC-FM ^a	SNAP-AOD-29 SNAP-AOD-29-HFi	SNAP-TEX-CBS6	Not used for analog modules

a Note that the SNAP-TEX-SBS6 cable does not include a connector for the 2-pin terminal on top of these modules, required for excitation voltage.

b Not recommended for use with breakout boards due to CT safety concerns.

c Do not use breakout boards with thermocouples.

High-Density Digital Modules

Module	Breakout Board							Without a breakout board
	SNAP-TEX-32	SNAP-TEX-FB16-H SNAP-TEX-FB16-L	SNAP-TEX-MR10-4 SNAP-TEX-MR10-16 SNAP-TEX-MR10-16C	SNAP-IDC-HDB SNAP-IDC-HDB-FM	SNAP-ODC-HDB SNAP-ODC-HDB-FM	SNAP-UJC-HDB	SNAP-UJC-HDB-G4	
SNAP-IAC-16 SNAP-IAC-A-16 SNAP-IAC-K-16 SNAP-IDC-16 SNAP-IDC-HT-16	SNAP-HD-ACF6 (2 modules/ board)	SNAP-HD-ACF6	Not used with inputs	Not used	Not used	Not used	Not used	SNAP-HD-ACF6
SNAP-IDC-32 SNAP-IDC-32-FM SNAP-IDC-32D SNAP-IDC-32N SNAP-IDC-32DN	SNAP-HD-CBF6	SNAP-HD-CBF6 (2 boards/ module)	Not used with inputs	SNAP-HD-BF6	Not used	SNAP-HD-BF6	Not used SNAP-HD-BF6	SNAP-HD-CBF6
SNAP-ODC-32-SNK SNAP-ODC-32-SNK-FM	SNAP-HD-CBF6	SNAP-HD-CBF6 (2 boards/ module)	Do not use	Not used			SNAP-HD-BF6	
SNAP-ODC-32-SRC SNAP-ODC-32-SRC-FM	SNAP-HD-CBF6	SNAP-HD-CBF6 (2 boards/ module)	SNAP-HD-CBF6 SNAP-HD-G4F6 (MR10-16C only)	Not used	SNAP-HD-BF6	SNAP-HD-BF6	Not used	SNAP-HD-CBF6

Analog Modules with More Than 4 Points

Module	Breakout Board			Without a breakout board
	SNAP-TEX-32	SNAP-TEX-FB16-H SNAP-TEX-FB16-L SNAP-TEX-MR10-4 SNAP-TEX-MR10-16 SNAP-TEX-MR10-16C SNAP-IDC-HDB SNAP-IDC-HDB-FM SNAP-ODC-HDB SNAP-ODC-HDB-FM	SNAP-AIMA-HDB SNAP-AIMA-HDB-FM	
SNAP-AICTD-8 SNAP-AIMA-8 SNAP-AIR400K-8 SNAP-AIRTD-8U SNAP-AITM-8 ** SNAP-AITM-8-FM ** SNAP-AIV-8	Can be used; no cable currently available	Not used with analog modules	Not used	No cable available
SNAP-AIMA-32 SNAP-AIMA-32-FM	Not recommended		SNAP-HD-BF6	SNAP-HD-BF6* Not recommended
SNAP-AIV-32 SNAP-AIV-32-FM	SNAP-HD-CBF6		Not used	SNAP-HD-BF6 SNAP-HD-CBF6
SNAP-AOVA-8	SNAP-HD-20F6			Not used SNAP-HD-20F6

* For specific applications. See details in wiring diagrams.

** Do not use breakout boards with thermocouples.

CABLES FOR 1-, 2-, OR 4-PT MODULES: SNAP-TEX-CB06, SNAP-TEX-CBE6, SNAP-TEX-CBS6

These three cables provide neat, protected wiring from the top of a 1-, 2-, or 4-point module to the breakout board. Each cable snaps into the top of one module and terminates at the breakout board with 18-gauge, color-coded flying leads, already stripped and tinned and ready for wiring. The leads attach easily to the breakout board with spring connectors.

SNAP-TEX-CB06—Odd-numbered terminals are commoned.

SNAP-TEX-CBE6—Even-numbered terminals are commoned.

SNAP-TEX-CBS6—No common terminals; wiring is straight through.

See the tables starting on [page 2](#) to determine the correct cable for your module and breakout board.



This photo shows the contrast between a regularly wired SNAP PAC rack (at upper left) and one using SNAP-TEX-CBE6, -CB06, and -CBS6 cables (at lower right).

The cables protect top-of-module connections and wires, and make it easier to follow wiring to field devices.



Cables terminate in color-coded flying leads, already stripped, tinned, and ready for wiring.

Installation, maintenance, and troubleshooting are faster and simpler using SNAP TEX cables.

CABLES FOR 1-, 2-, OR 4-POINT MODULES (CONTINUED)

Cable Specifications

See the tables starting on [page 2](#) for module, cable, and breakout board compatibility.

Feature	SNAP-TEX-CBO6	SNAP-TEX-CBE6	SNAP-TEX-CBS6
Cable length	6 feet (1.8 meters)	6 feet (1.8 meters)	6 feet (1.8 meters)
Connector	8 pins, 0.2 in. (5.08 mm) center-to-center	8 pins, 0.2 in. (5.08 mm) center-to-center	8 pins, 0.2 in. (5.08 mm) center-to-center
Wires	8 pre-stripped, tinned, color-coded, 18 gauge	8 pre-stripped, tinned, color-coded, 18 gauge	8 pre-stripped, tinned, color-coded, 18 gauge
Bussing	Odd-numbered pins connected	Even-numbered pins connected*	No connections
Agency Approvals	CE, RoHS, DFARS	CE, RoHS, DFARS	CE, RoHS, DFARS
Warranty	30 months	30 months	30 months

*Do NOT USE the CBE6 with a SNAP-TEX-FB16-H or -L breakout board. The FB16s have odd-numbered pins connected.

Wire Colors

Point	Pin	Color wire
0	1	black
	2	red
1	3	blue
	4	orange

Point	Pin	Color wire
2	5	yellow
	6	brown
3	7	red/black
	8	blue/black



Wiring diagrams begin on [page 24](#).

CABLE FOR 8-POINT ANALOG OUTPUT MODULE: SNAP-HD-20F6

The SNAP-HD-20F6 cable is designed for use with an 8-channel SNAP-AOVA-8 analog output module. The cable has a 20-pin connector at the module end and flying leads for field wiring.

You can also use the cable and module with a SNAP-TEX-32 breakout board (four modules per board). See [page 32](#) for a wiring diagram.



SNAP-HD-20F6 Cable

SNAP-AOVA-8 Module (from top)

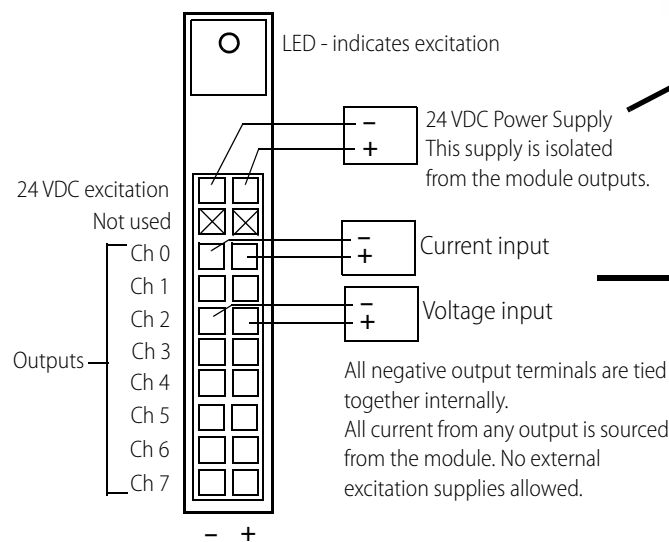

Wire colors - Excitation

24 VDC	Color
-	Black
+	White with Black

Wire colors - Output points

Ch	-/+	Color
0	-	Blue
	+	White with Blue
1	-	Pink
	+	White with Pink
2	-	Gray
	+	White with Gray
3	-	Green
	+	White with Green
4	-	Orange
	+	White with Orange
5	-	Red
	+	White with Red
6	-	Purple
	+	White with Purple
7	-	Yellow
	+	White with Yellow



For more information on the SNAP-AOVA-8 module, see the [SNAP Analog Output Modules Data Sheet](#) (form 1066).

NOTE: Yellow with purple and purple with yellow wires are not used.

CABLES FOR 16- OR 32-POINT MODULES: SNAP-HD-ACF6, SNAP-HD-CBF6, SNAP-HD-BF6

The SNAP-HD-ACF6, SNAP-HD-CBF6, and SNAP-HD-BF6 cables connect 16- and 32-channel modules to field wiring or breakout boards. Each cable is 6 ft. (1.8 m) long.

The **SNAP-HD-ACF6** and the **SNAP-HD-CBF6** have connectors at one end that attach to the top of a module and flying leads at the other end for field wiring. The ACF6 is for 16-channel modules and includes two cables, each cable wiring 8 channels. The CBF6 is for 32-channel modules.

The **SNAP-HD-BF6** has connectors at both ends, one for a 32-channel module and the other for a suitable breakout rack.



SNAP-HD-CBF6



SNAP-HD-BF6



SNAP-HD-ACF6

Cable Specifications

See tables starting on [page 2](#) for detailed module, cable, and breakout board compatibility. Wiring diagrams begin on [page 24](#).

Feature	SNAP-HD-ACF6	SNAP-HD-CBF6	SNAP-HD-BF6
Cable length	6 feet (1.8 meters)	6 feet (1.8 meters)	6 feet (1.8 meters)
Connectors	Two-cable assembly; 16-pin connector at module end; flying leads at other end	One 40-pin connector at module end; flying leads at other end	One connector at module end; one connector at breakout board end
Wires	Pre-stripped, tinned, color-coded, 22-gauge wires	Pre-stripped, tinned, color-coded, 24-gauge wires	24-gauge wires
Use with	Modules: SNAP-IAC-16 SNAP-IAC-A-16 SNAP-IAC-K-16 SNAP-IDC-16 SNAP-IDC-HT-16	Modules: SNAP-IDC-32 SNAP-IDC-32-FM SNAP-IDC-32N SNAP-IDC-32D SNAP-IDC-32DN SNAP-ODC-32-SNK SNAP-ODC-32-SNK-FM SNAP-ODC-32-SRC SNAP-ODC-32-SRC-FM SNAP-AIV-32 SNAP-AIV-32-FM	Modules to breakout boards (regular and -FM versions): SNAP-IDC-32 to SNAP-IDC-HDB or SNAP-UDC-HD SNAP-IDC-32N to SNAP-IDC-HDB, SNAP-UDC-HDB, or SNAP-UDC-HDB-G4 SNAP-IDC-32D to SNAP-IDC-HDB or SNAP-UDC-HDB SNAP-IDC-32DN to SNAP-IDC-HDB, SNAP-UDC-HDB, or SNAP-UDC-HDB-G4 SNAP-ODC-32-SNK to SNAP-ODC-HDB, SNAP-UDC-HDB, or SNAP-UDC-HDB-G4 SNAP-ODC-32-SRC to SNAP-ODC-HDB or SNAP-UDC-HDB SNAP-AIV-32 to SNAP-AIV-HDB SNAP-AIMA-32 to SNAP-AIMA-HDB SNAP-AIMA-32 to SNAP-AIV-HDB*
Agency Approvals	CE, RoHS, DFARS	CE, RoHS, DFARS	CE, RoHS, DFARS
Warranty	30 months	30 months	30 months

* Special application; see wiring diagrams.

CABLES TO CONNECT G4 TO SNAP: SNAP-HD-G4F6, SNAP-HD-G4F6N

The SNAP-HD-G4F6 and cables are used to connect a SNAP high-density digital (HDD) module to G4 mounting racks in order to integrate older G4 (or even G1) digital output systems with modern PAC Project software and SNAP PAC Ethernet-based controllers.

For outputs, this connection makes available the G4 output's up to 3-amp switching and sensing capability, which can provide twelve times the 0.25 amp capability of the HDD modules themselves. (For G4 module specs, see Opto 22 form #727, the *G4 Digital I/O Data Book*.)

NOTE: For another option, see the SNAP-UDC-HDB-G4 on page 20.

Each cable connects two 16-channel mounting racks to one 32-point digital module. Cables can also be used to connect G1 mounting racks with header connectors to these modules. See the table below for module and rack compatibility.

The SNAP-HD-G4F6 cable can also be used to connect two SNAP-TEX-MR10-16C breakout boards to one 32-point digital module. See "[Breakout Boards with Mechanical Relays: SNAP-TEX-MR10-4, SNAP-TEX-MR10-16, and SNAP-TEX-MR10-16C](#)" on page 13.

For more information on HDD modules, see the [SNAP High-Density Digital Module Data Sheet](#) (form 1556).

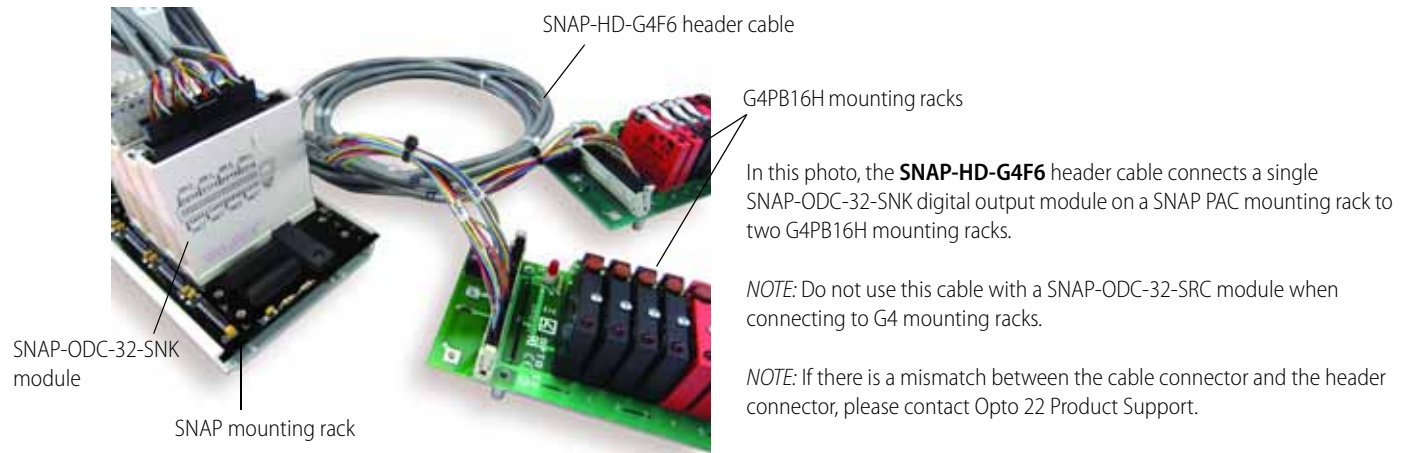

Cable Specifications

Feature	SNAP-HD-G4F6	SNAP-HD-G4F6N
Cable length	6 feet (1.8 meters)	6 feet (1.8 meters)
Connectors	One connector at module end; two header connectors at rack end	One connector at module end; two header connectors at rack end
Use with	32-point digital output modules	32-point digital input modules
Agency approvals	CE, RoHS, DFARS	CE, RoHS, DFARS
Warranty	30 months	30 months

Compatible Modules and Racks

Cable	Modules	Racks	Integrated I/O
SNAP-HD-G4F6	SNAP-ODC-32-SNK	G4PB16H	PB16H
	SNAP-ODC-32-SNK-FM	G4PB16HC	PB16HC
SNAP-HD-G4F6N	SNAP-IDC-32N*	G4PB16H	PB16H
	SNAP-IDC-32DN*	G4PB16HC	PB16HC

* For 15 volt or 24 volt G1 or G4 modules, use the SNAP-IDC-32N.
For 5 volt modules, use the SNAP-IDC-32DN.

SNAP-HD-G4F6 cable



NOTE: While not designed for this use, it is possible to connect the SNAP-IDC-32 module with G4 15 or 24 V inputs using a SNAP-HD-G4F6 cable. However, the SNAP-IDC-32 uses positive-true logic and therefore returns the inverse of the typical negative-true logic. For example, if the SNAP-IDC-32 is controlled by a PAC Control strategy, an "OFF" state from it actually indicates that the associated G4 module is turned ON.

BREAKOUT BOARDS—ASSEMBLY AND INSTALLATION

All breakout boards that come with a plastic extrusion can be panel mounted or DIN-rail mounted. DIN-rail clips are sold separately; see the [SNAP TEX Mounting/Wiring Tools Data Sheet](#) (form 1772).

CAUTION: Do not let cutting fluids, cleaners, lubricants, or other chemicals contact the plastic extrusion, as they can cause cracking. If you use these chemicals before rack installation, be sure they are thoroughly cleaned off.

Panel mounting

1. Place the extrusion in position on the panel and mount it using the holes provided.
2. Insert one edge of the circuit board into the extrusion.

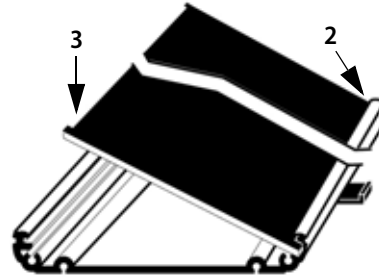

DIN-rail mounting

1. For boards that use three or more DIN-rail clips: slide one DIN clip to the middle position and secure with the rivet provided. For racks with four clips, add an additional middle clip.
2. Insert one edge of the circuit board into the extrusion.
3. Push down hard on the other edge to snap the board into place.
4. Attach one DIN clip to each end cap using the slots in the end caps as shown.
5. Using the screws provided, secure an end cap and DIN clip assembly to each end of the extrusion.

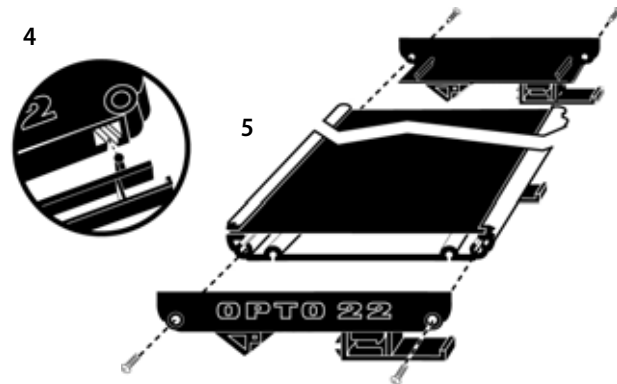
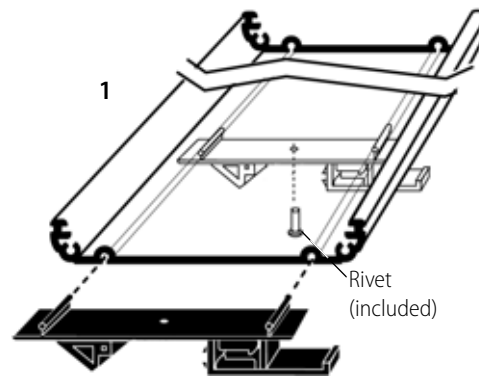

Removing the Circuit Board from the Rack Extrusion

If end caps are present, remove them. Then insert a flathead screwdriver in one of the circuit board release notches and pry up the board. Repeat in the other release notches until the board pops out of the extrusion.

Attaching the Adapter Clip to a DIN Rail

1. Hook the DIN-rail clip over the top of the DIN rail.
2. Using a screwdriver, pry open the DIN-rail clip flange at the bottom of the clip. Push the clip toward the DIN rail.
3. Snap the DIN-rail clip into place.

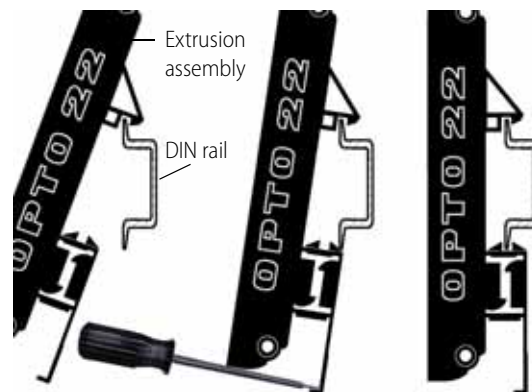

BREAKOUT BOARDS: SNAP-TEX-32, SNAP-TEX-FB16-H, SNAP-TEX-FB16-L

The **SNAP-TEX-32** is a simple breakout board with straight-through wiring. Designed primarily for 2- and 4-point analog inputs/outputs and for 4-point digital inputs, the breakout board is used with SNAP-TEX cables. The board can be used with digital outputs, but it does not have fuses.

The SNAP-TEX-32 can also be used with 8-, 16-, or 32-point SNAP analog modules (not thermocouples). See the table beginning on [page 2](#) for recommended cable and board combinations for your modules.

The **SNAP-TEX-FB16-H** and **SNAP-TEX-FB16-L** breakout boards provide a fuse and a fuse-blown indicator for each of their 16 channels. In addition, they provide power to loads: the SNAP-TEX-F16-H provides 120–240 volts, and the SNAP-TEX-F16-L provides 12–24 volts. Simply attach the power source to a single spot in the middle of the rack, and power goes out to solenoids or switches, depending on the module you’re using. These breakout boards are used primarily for digital inputs and outputs.

CAUTION: Odd pins on the SNAP-TEX-FB16-H and SNAP-TEX-FB16-L breakout boards are commoned. Use only straight-through or odd cables with these boards.



SNAP-TEX-FB16-H

Specifications

See the table beginning on [page 2](#) for recommended cable and board combinations. Wiring diagrams begin on [page 24](#).

Feature	SNAP-TEX-32	SNAP-TEX-FB16-H	SNAP-TEX-FB16-L
Use with I/O modules	2- or 4-point analog inputs/outputs; 4-point digital inputs/outputs*; 8-, 16-, or 32-point digital and analog outputs (not thermocouples)	4-point digital inputs and outputs 16- and 32-pt digital inputs/outputs	4-point digital inputs and outputs 16- and 32-pt digital inputs/outputs
Use with cables	SNAP-TEX-CBE6 (even pins connected), SNAP-TEX-CBO6 (odd pins connected), or SNAP-TEX-CBS6 (no connections), depending on module. SNAP-HD-20F6 with a SNAP-AOVA-8 module.	4-ch modules: SNAP-TEX-CBO6 (odd pins connected)** or SNAP-TEX-CBS6 (straight-through), depending on module. 16-ch modules: SNAP-HD-ACF6 32-ch modules: SNAP-HD-CBF6	4-ch modules: SNAP-TEX-CBO6 (odd pins connected)** or SNAP-TEX-CBS6 (straight-through), depending on module. 16-ch modules: SNAP-HD-ACF6 32-ch modules: SNAP-HD-CBF6
Connectors	32 spring connectors; accommodates eight 4-point modules	16 spring connectors; accommodates four 4-point modules	16 spring connectors; accommodates four 4-point modules
Fusing	none	1 A, 250 V, fast-acting fuse for each I/O point (16 total). Replace with Opto 22 PN FUSE01G4	1 A, 250 V, fast-acting fuse for each I/O point (16 total). Replace with Opto 22 PN FUSE01G4
Indicators	none	1 blown-fuse LED per fuse (16 LEDs total)	1 blown-fuse LED per fuse (16 LEDs total)
Bussed power	none	120–240 V	12–24 V
Agency Approvals	CE, RoHS, DFARS; UKCA	UL, CE, RoHS, DFARS	UL, CE, RoHS, DFARS; UKCA
Warranty	30 months	30 months	30 months

* Can be used with digital outputs but does not have fuses. SNAP-TEX-FB16 boards have fuses; they are better for digital outputs.

** **IMPORTANT:** Do NOT USE the FB16 breakout boards with a SNAP-TEX-CBE6 cable. The board has odd pins connected; the cable has even pins connected.

BREAKOUT BOARDS: SNAP-TEX-32, SNAP-TEX-FB16-H, SNAP-TEX-FB16-L (CONTINUED)

Dimensions—SNAP-TEX-32 Breakout Board

Dimensions are shown in inches (with centimeters in parentheses).

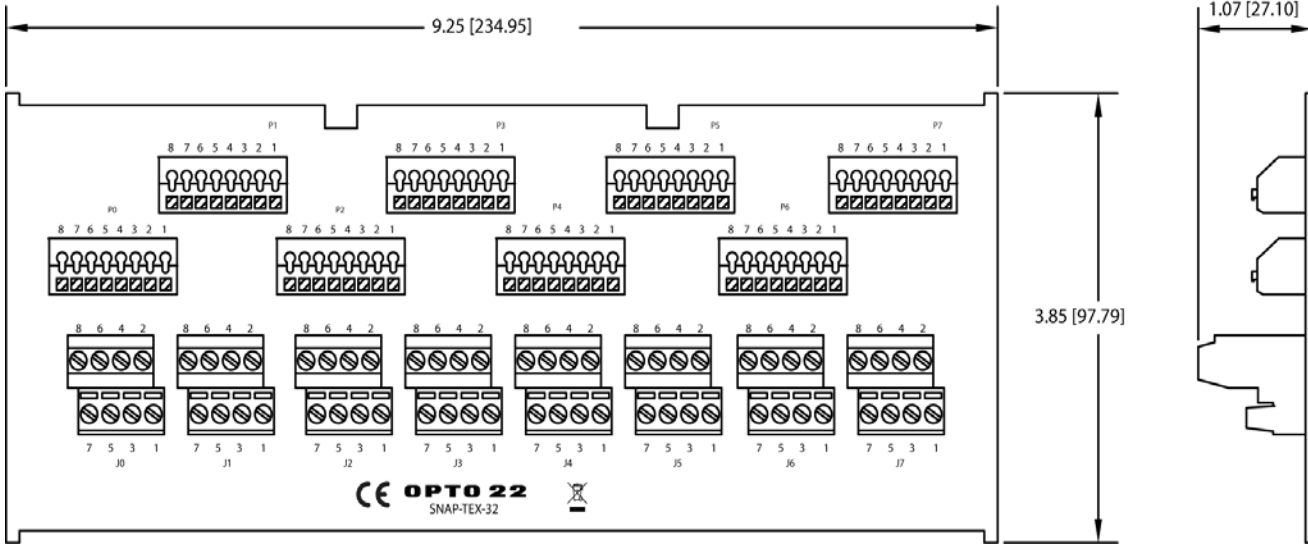

Dimensions—SNAP-TEX-FB16-H and SNAP-TEX-FB16-L Breakout Boards

Dimensions are shown in inches (with centimeters in parentheses).

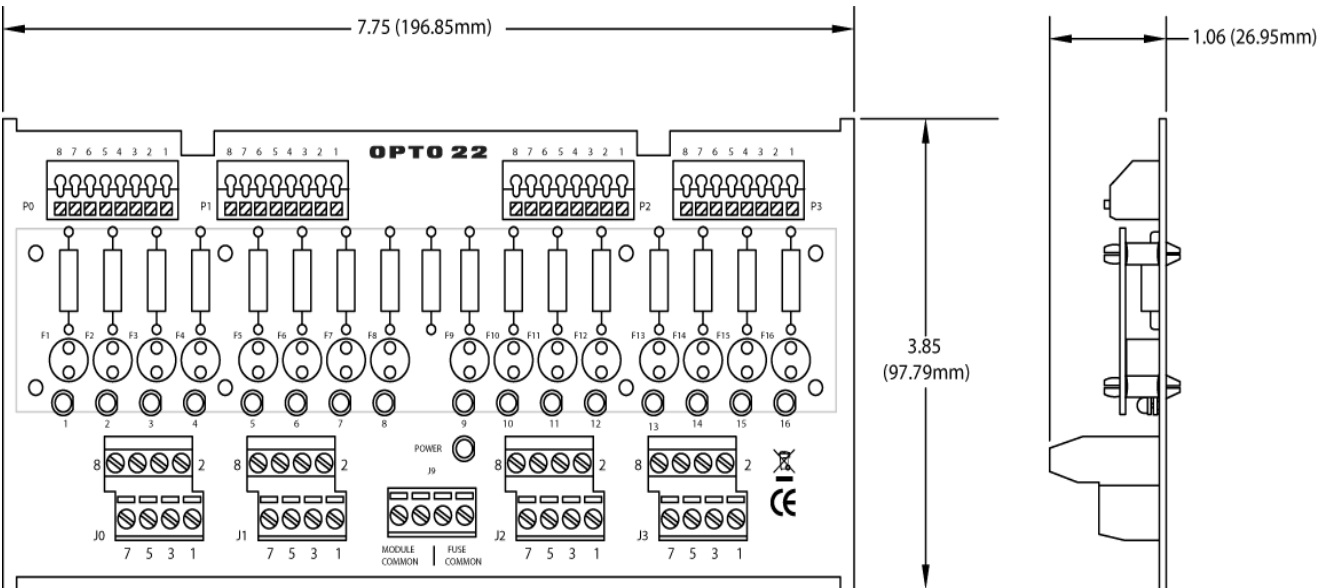

BREAKOUT BOARDS WITH MECHANICAL RELAYS: SNAP-TEX-MR10-4, SNAP-TEX-MR10-16, AND SNAP-TEX-MR10-16C

The **SNAP-TEX-MR10-4**, **SNAP-TEX-MR10-16**, and **SNAP-TEX-MR10-16C** breakout boards, designed for high-current switching, feature mechanical relays that can switch up to 10 A per channel. (Standard SNAP output modules can switch up to 0.75 A; SNAP-OMR6 output modules can switch up to 6 A.)

These breakout boards include on/off indicators for each channel, and each channel can be wired for normally closed or normally open.

The boards require 24 VDC power. A replacement relay is available: part number SNAP-MR10.

NOTE: Transient protection must be used on inductive loads.



SNAP-TEX-MR10-4



SNAP-TEX-MR10-16

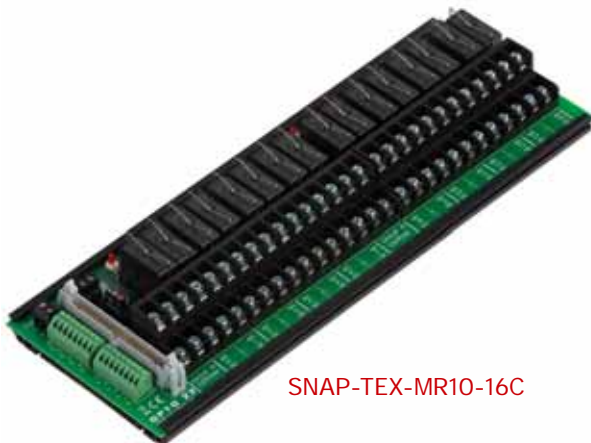

SNAP-TEX-MR10-16C

With the **SNAP-TEX-MR10-16C**, you can connect digital output modules in two ways:

- Connect four standard 4-point ODC modules using the two *spring connectors* and the appropriate cable for the modules (see [page 30](#)).
- Connect one SNAP-ODC-32-SRC high-density module to the *header connectors* on two MR10-16C breakout boards. Requires a SNAP-HD-G4F6 cable (see [page 50](#)).

Also, bussed commons in 2-channel groups provide easier wiring of loads. Bussing straps (STRAP2Q and STRAP4Q) can be used for quick common power connections between relay groups (see [page 31](#)).

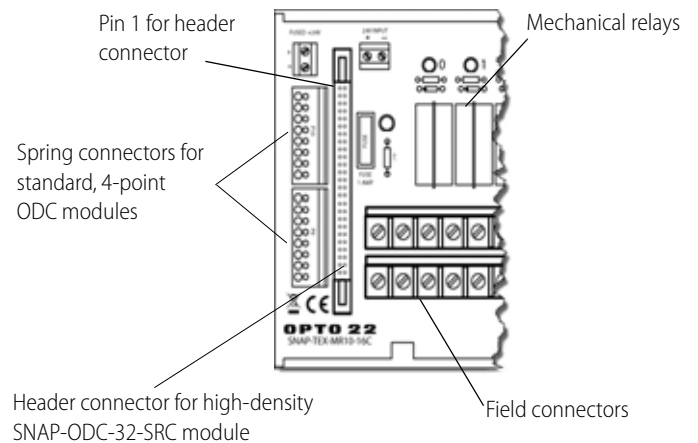

BREAKOUT BOARDS WITH MECHANICAL RELAYS (CONTINUED)

Specifications

See the tables beginning on [page 2](#) for compatible modules and cables. Wiring diagrams begin on [page 24](#).

Feature	SNAP-TEX-MR10-4 SNAP-TEXMR10-16	SNAP-TEX-MR10-16C
Use with I/O modules	SNAP-ODC5-i, SNAP-ODC5A-i, SNAP-ODC5SRC, SNAP-ODC-32-SRC	SNAP-ODC5-i, SNAP-ODC5A-i, SNAP-ODC5SRC, SNAP-ODC-32-SRC
Use with cables	SNAP-TEX-CBO6 (odd pins bussed), SNAP-TEX-CBS6 (no bussing), or SNAP-HD-CBF6, depending on module	<ul style="list-style-type: none"> For one high-density SNAP-ODC-32-SRC module, use a SNAP-HD-G4F6 cable to connect two breakout boards to one module. For four 4-point modules, use SNAP-TEX-CBO6 (odd pins bussed) or SNAP-TEX-CBS6 (no bussing), depending on module.
Use with jumper straps	–	STRAP2Q, STRAP4Q
Relay contacts	SPDT (1 Form C) Typical life expectancy (Electrical): 1×10^5	SPDT (1 Form C) Typical life expectancy (Electrical): 1×10^5
Switching capacity	10 A @ 240 VAC	10 A @ 240 VAC
Switch On time	7 ms nominal	7 ms nominal
Switch Off time	3 ms nominal	3 ms nominal
Fusing	24 V fuse for board. Opto 22 p/n SNAP-FUSE1AC	24 V fuse for board. Opto 22 p/n SNAP-FUSE1AC
Indicators	On/Off status indicators (one for each channel) 1 fuse-blown indicator	On/Off status indicators (one for each channel) 1 fuse-blown indicator
Power requirements (all positions On)	24 VDC @ 75 mA	24 VDC @ 300 mA
Agency Approvals	UL, CE, RoHS, DFARS; UKCA	UL, CE, RoHS, DFARS
Warranty	30 months from date of manufacture	30 months from date of manufacture

Dimensional Drawing—SNAP-TEX-MR10-4 Breakout Board

Dimensions are shown in inches (with centimeters in parentheses).

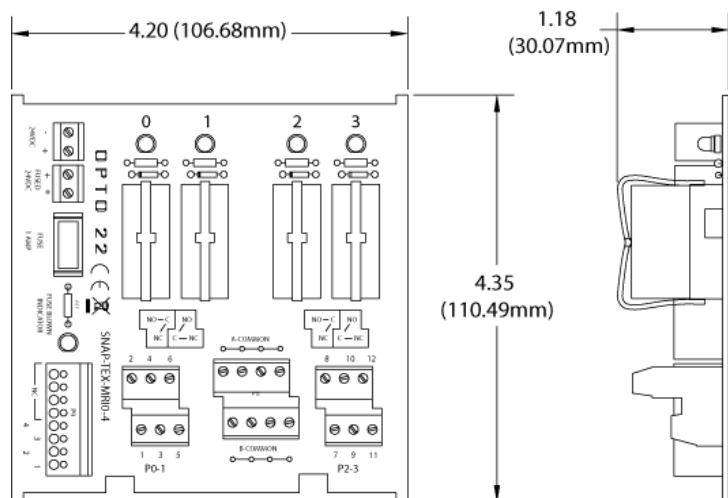

BREAKOUT BOARD WITH MECHANICAL RELAYS (CONTINUED)

Dimensional Drawing—SNAP-TEX-MR10-16 Breakout Board

Dimensions are shown in inches (with centimeters in parentheses).

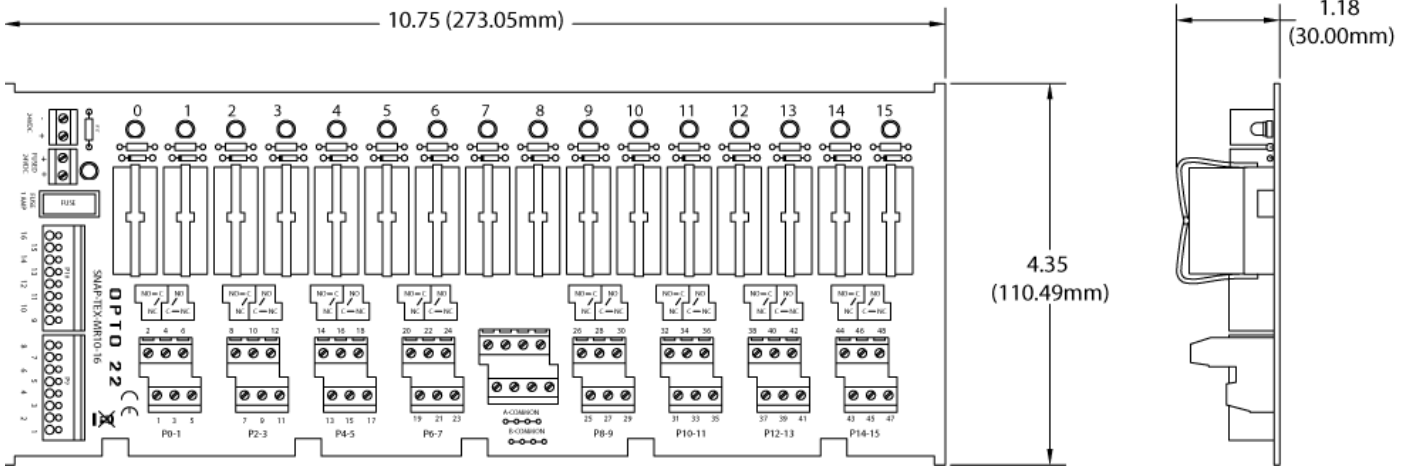

Dimensional Drawing—SNAP-TEX-MR10-16C Breakout Board

Dimensions are shown in inches (with centimeters in parentheses).

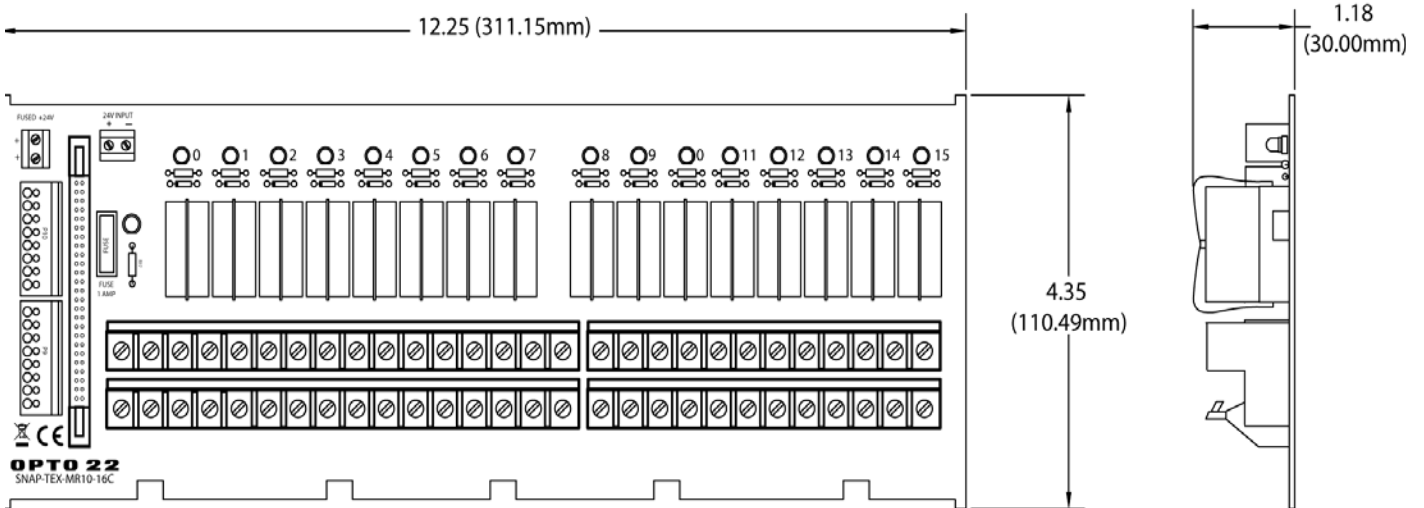

BREAKOUT BOARD FOR 32-POINT DIGITAL MODULES: SNAP-UDC-HDB

The small-footprint SNAP-UDC-HDB breakout board can be used with either SNAP 32-point input modules or SNAP 32-point output modules.

This breakout board is ideal for tight locations. To save space, it does not provide fuses. Spring-clamp wiring connectors make wiring the board faster and simpler.

Connect the SNAP 32-point module to the board using a SNAP-HD-BF6 cable (see [page 8](#)).

Dimensional diagrams are on the next page. Wiring diagrams are on [page 38](#).



Specifications

SNAP-UDC-HDB Breakout Rack for High-Density Digital Input and Output Modules

Used with	SNAP-IDC-32, SNAP-IDC-32-FM SNAP-IDC-32N, SNAP-IDC-32D, SNAP-IDC-32DN SNAP-ODC-32-SNK, SNAP-ODC-32-SNK-FM SNAP-ODC-32-SRC, SNAP-ODC-32-SRC-FM
Connectors	40-pin header connects to 32-point module using SNAP-HD-BF6 cable. 64 spring-clamp terminal block provides 1 connection for each of 32 channels, 4 connections per 8-channel zone for field common, and 4 connections per 8-channel zone for module common.
Wire size	Field connector: 12-28 AWG
Indicators	1 LED status indicator for each point (32 LEDs total)
Jumpers	When using any SNAP-IDC-32 input module, install all four jumpers (JP1–JP4) in X positions. When using any SNAP-ODC-32 output module, install all four jumpers in Z positions.
Voltage	32 VDC maximum, 12–24 VDC nominal
Agency Approvals	UL, CE, RoHS, DFARS
Warranty	30 months from date of manufacture

BREAKOUT BOARDS FOR 32-POINT DIGITAL MODULES (CONTINUED)

Dimensional Drawing—SNAP-UDC-HDB

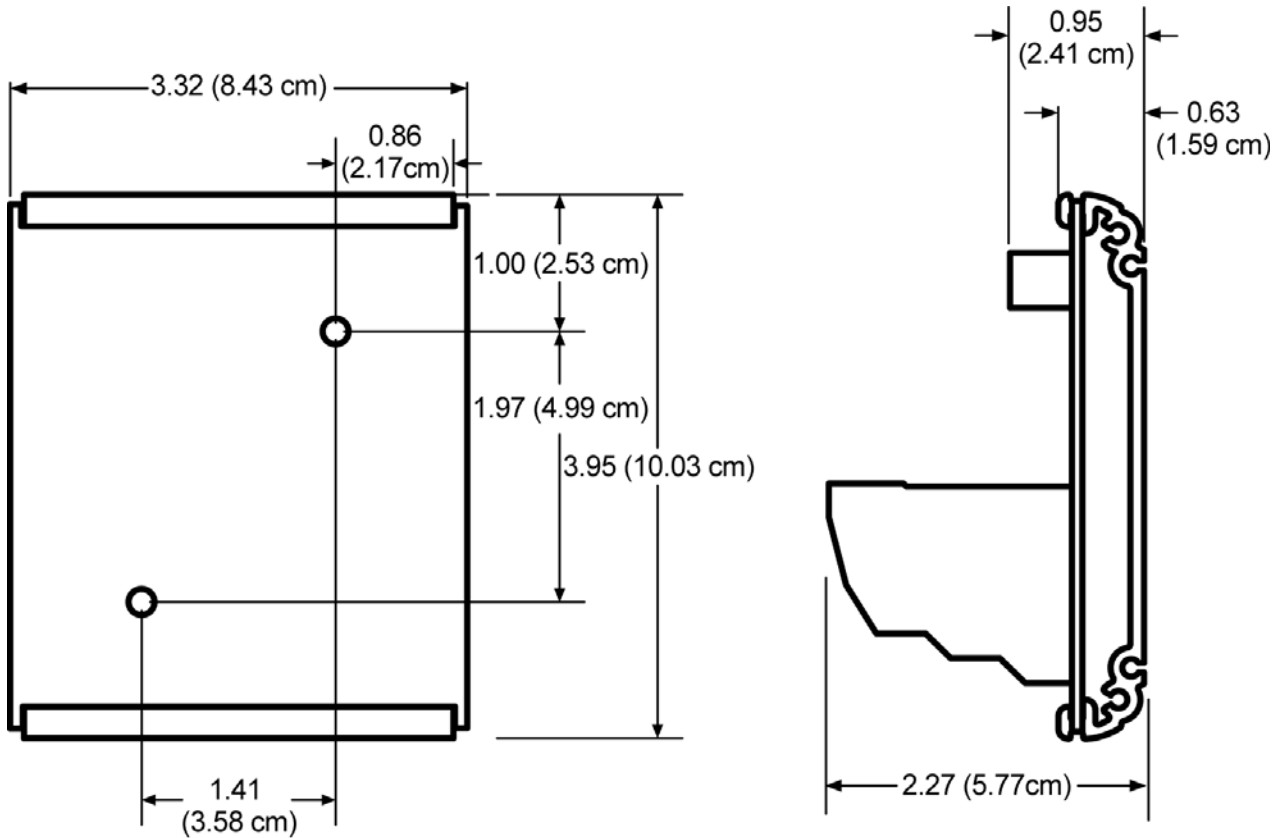

BREAKOUT BOARDS FOR 32-POINT DIGITAL MODULES: SNAP-IDC-HDB, SNAP-ODC-HDB

SNAP-IDC-HDB, SNAP-IDC-HDB-FM, SNAP-ODC-HDB, and SNAP-ODC-HDB-FM breakout boards provide LED indicators and easily accessible fused connectors for points on 32-point digital input or output modules.

Wiring diagrams begin on [page 43](#).

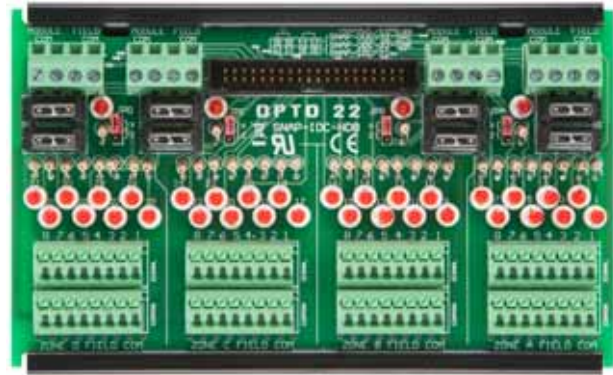

Specifications

SNAP-IDC-HDB and SNAP-IDC-HDB-FM Breakout Racks for High-Density Digital Input Modules

Used with	SNAP-IDC-32, SNAP-IDC-32-FM, SNAP-IDC-32N, and SNAP-IDC-32DN
Connectors	40-pin header connects to 32-point input module using SNAP-HD-BF6 header cable. 32 signal input connectors; each signal connector has a corresponding common connector. For each zone of 8 signal inputs, 1 connection for either module common or field common. Wire size for field connectors: 16-20 AWG
Indicators	1 LED for On/Off status of each signal input (32 signal LEDs total) 1 power status LED for each zone of 8 signal inputs (4 power LEDs total)
Fusing	2 fuses (Module Common, Field Common) for each zone of 8 signal inputs (8 fuses total) 1 A fuses; replace with Pudenz 1 A automobile mini-fuse or equivalent.
Jumpers	For each zone of 8 signal inputs, 1 jumper controls whether module common or field common is used. Set jumpers to X position for digital input modules.
Voltage	32 VDC maximum, 12-24 VDC nominal
Agency Approvals	SNAP-IDC-HDB: UL, CE, RoHS, DFARS SNAP-IDC-HDB-FM: FM, CE, RoHS, DFARS
Warranty	30 months from date of manufacture

SNAP-ODC-HDB and SNAP-ODC-HDB-FM Breakout Racks for High-Density Digital Output Modules

Used with	SNAP-ODC-32-SRC, SNAP-ODC-32-SRC-FM, SNAP-ODC-32-SNK, and SNAP-ODC-32-SNK-FM
Connectors	40-pin header; connects to 32-point sourcing or sinking module using SNAP-HD-BF6 header cable. 32 signal output connectors; each signal connector has a corresponding common connector. For each zone of 8 signal outputs, 1 connection for either module common or field common. Wire size for field connectors: 16-20 AWG
Indicators	1 LED for On/Off status of each signal output (32 signal LEDs total) 1 power status LED for each zone of 8 signal outputs (4 power LEDs total)
Fusing	1 A fuses; 1 fuse for each signal output (32 signal fuses total) Replace with Pudenz 1 A automobile mini-fuse or equivalent.
Jumpers	For each zone of 8 signal inputs, 1 jumper controls whether module common or field common is used. Set jumpers to Z position for digital output modules.
Voltage	32 VDC maximum, 12-24 VDC nominal
Agency Approvals	SNAP-ODC-HDB: UL, CE, RoHS, DFARS SNAP-ODC-HDB-FM: FM, CE, RoHS, DFARS
Warranty	30 months from date of manufacture

BREAKOUT BOARDS FOR 32-POINT DIGITAL MODULES (CONTINUED)

Dimensional Drawings

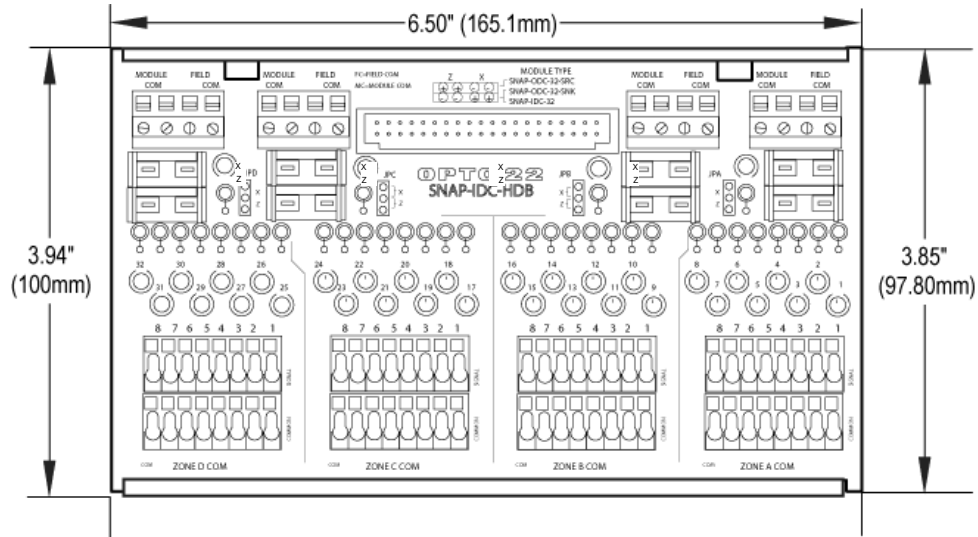

SNAP-IDC-HDB and SNAP-IDC-HDB-FM breakout racks

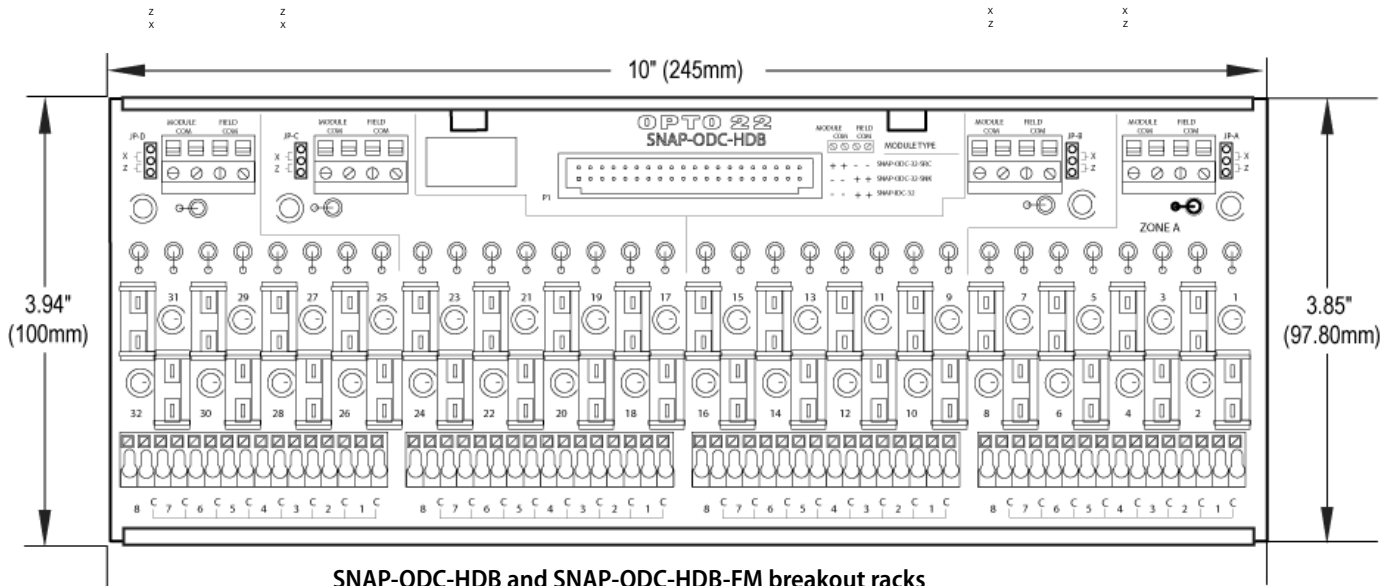

SNAP-ODC-HDB and SNAP-ODC-HDB-FM breakout racks

BREAKOUT BOARDS FOR 32-POINT DIGITAL MODULES: SNAP-UDC-HDB-G4

The SNAP-UDC-HDB-G4 breakout board connects a SNAP 32-point digital module to **G4 modules** on the board, so you can switch or monitor much larger loads than the SNAP module can handle by itself.

The SNAP-UDC-HDB-G4 holds 32 G4 modules (sold separately), one for each point on the SNAP module.

A SNAP 32-point digital output module like the SNAP-ODC-32-SNK can switch loads of 0.25 amps per point, but by going through G4 output modules on the board, it can switch loads of up to 3 amps per point.

The module connects to the board using a SNAP-HD-BF6 cable (see [page 8](#)). G4 modules on the board can be a mix of AC and DC, but they must be all inputs or all outputs, depending on the SNAP module they are connected to.

The board provides spring-clamp terminals for easier field wiring. Dimensional diagrams are on [page 21](#). Wiring diagrams begin on [page 41](#).



Specifications

SNAP-UDC-HDB-G4 Breakout Rack for High-Density Digital Input or Output Module	
Used with	Outputs: SNAP-ODC-32-SNK or SNAP-ODC-32-SNK-FM (all G4 modules must be the same voltage) Inputs: SNAP-IDC-32DN for 5 V G4 modules; SNAP-IDC-32N for 15 V or 24 V G4 modules
Connectors	40-pin header connects to 32-point module using SNAP-HD-BF6 cable. 64 spring-clamp terminals provide 2 connections for each of 32 channels. Additional 4 spring-clamp terminals are for logic power + and – (2 each).
Wire size	Field connector: 12-28 AWG
Indicators	1 LED for logic power; 1 LED for G4 fuse test
Jumpers	When using a SNAP-ODC-32-SNK output module, install JP1 in the negative (–) position. When using a SNAP-IDC-32 input module, install JP1 in the positive (+) position.
Voltage	32 VDC maximum, 12–24 VDC nominal
Agency Approvals	UL, CE, RoHS, DFARS
Warranty	30 months from date of manufacture

BREAKOUT BOARDS FOR 32-POINT DIGITAL MODULES (CONTINUED)

Dimensional Drawing—SNAP-UDC-HDB-G4

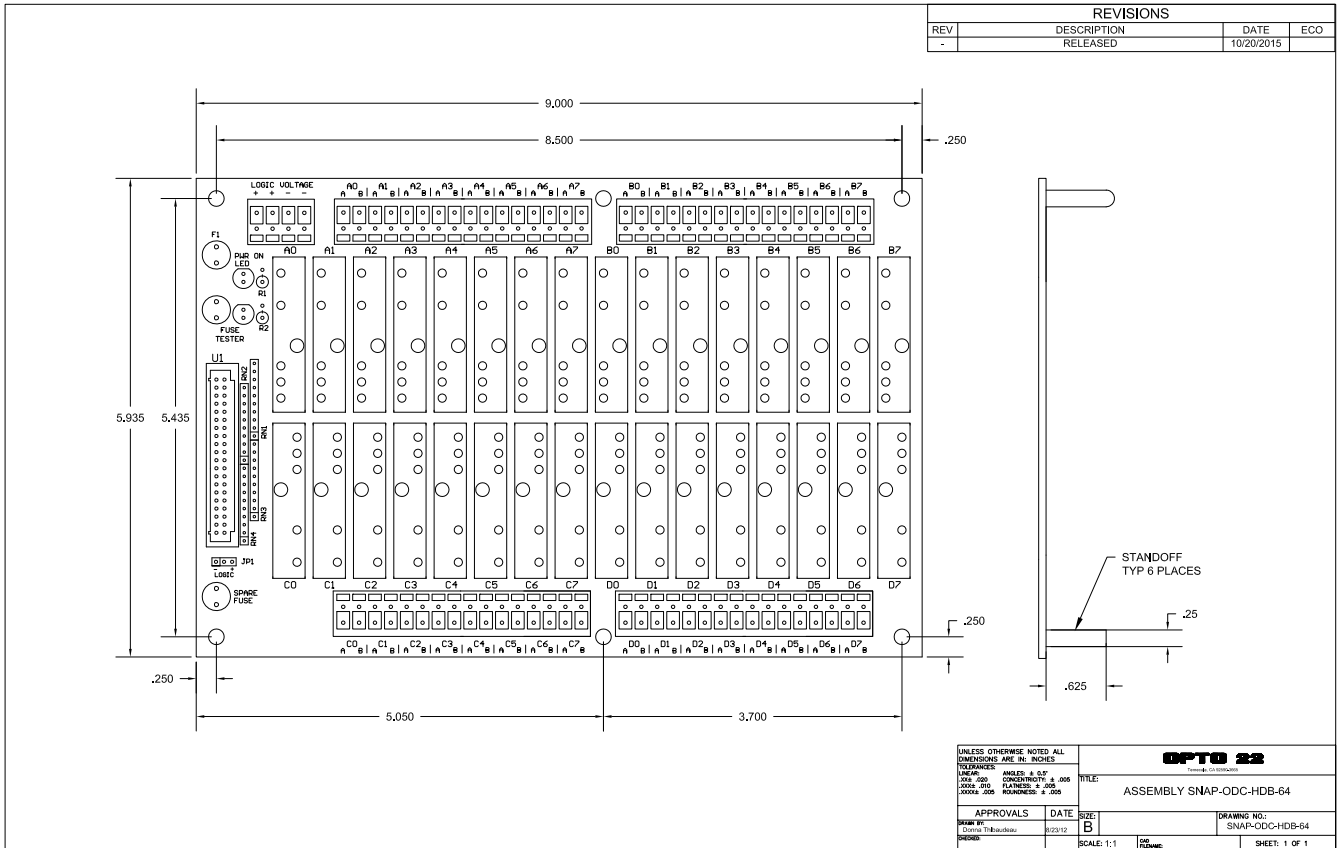

SNAP-UDC-HDB-G4 shown with G4 modules (sold separately)



BREAKOUT BOARDS FOR 32-POINT ANALOG MODULES: SNAP-AIMA-HDB AND SNAP-AIV-HDB



SNAP-AIMA-HDB breakout board

SNAP-AIMA-HDB, SNAP-AIMA-HDB-FM, SNAP-AIV-HDB, and SNAP-AIV-HDB-FM breakout boards are primarily designed for use with SNAP-AIMA-32, SNAP-AIMA-32-FM, SNAP-AIV-32, and SNAP-AIV-32-FM analog input modules, respectively. Each of these modules provides 32 input points. The breakout boards provide easy accessibility for wiring points to field devices. Use the SNAP-HD-BF6 cable for wiring connections between the module and the breakout board.

Note for the SNAP-AIMA-32 or SNAP-AIMA-32-FM: if you are using one of these modules with loop powered (2-wire) devices, connect to the SNAP-AIMA-HDB or SNAP-AIMA-HDB-FM rack as shown on [page 51](#). However, if you are using the SNAP-AIMA-32 (or -FM) with self-powered devices (4-wire), do not use the SNAP-AIMA-HDB (or -FM) boards, which have a current limiter. Instead, wire to the SNAP-AIV-HDB or SNAP-AIV-HDB-FM as shown on [page 52](#) (negative common) or [page 53](#) (positive common).

CAUTION: We strongly recommend that you use a breakout board with the SNAP-AIMA-32 (or -FM) module. Without the board, miswiring of any point on the module can cause severe out-of-warranty damage. The breakout board protects the module from many wiring errors.

Working with Module Values

AIMA modules used with a SNAP-AIV-HDB board read normally. However, values on AIMA modules used with a SNAP-AIMA-HDB board are read as *negative values*. For example, a value of 10 mA on the module will be read as -10 mA. (Note: If no readings appear, try reversing field connections on the board.)

Because these readings are negative values, they can be confusing to work with. This section shows you how to easily change them to positive values or scale them to the positive readings you need. This section applies only to the SNAP-AIMA-HDB board.

Changing Negative to Positive Values

(SNAP-AIMA-HDB board only) To read positive values, when you configure points on the module, choose the scalable option and enter the corresponding positive values, like this:

This may seem odd, but it works. Don't be confused by the "Lower" and "Upper" labels for the values. Positive values sent to the module will be shown as the correct positive values within your PAC Control strategy.

Scaling Values

Similarly, if you need to scale values for your application, enter the positive values you need. If you want the field signal of 4 to 20 mA to be scaled as 0 to 100%, then configure as shown below:

BREAKOUT BOARDS FOR 32-POINT ANALOG MODULES (CONTINUED)

Dimensional Drawing—SNAP-AIMA-HDB and SNAP-AIMA-HDB-FM Breakout Boards

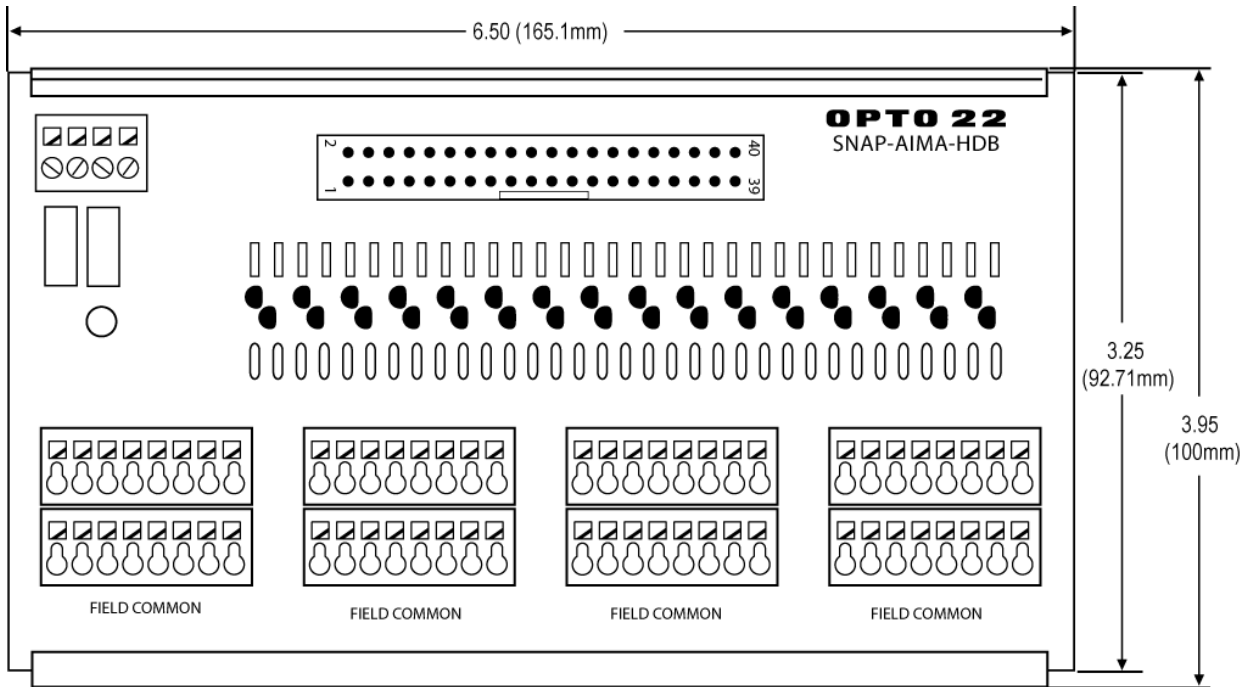

Dimensional Drawing—SNAP-AIV-HDB and SNAP-AIV-HDB-FM Breakout Boards

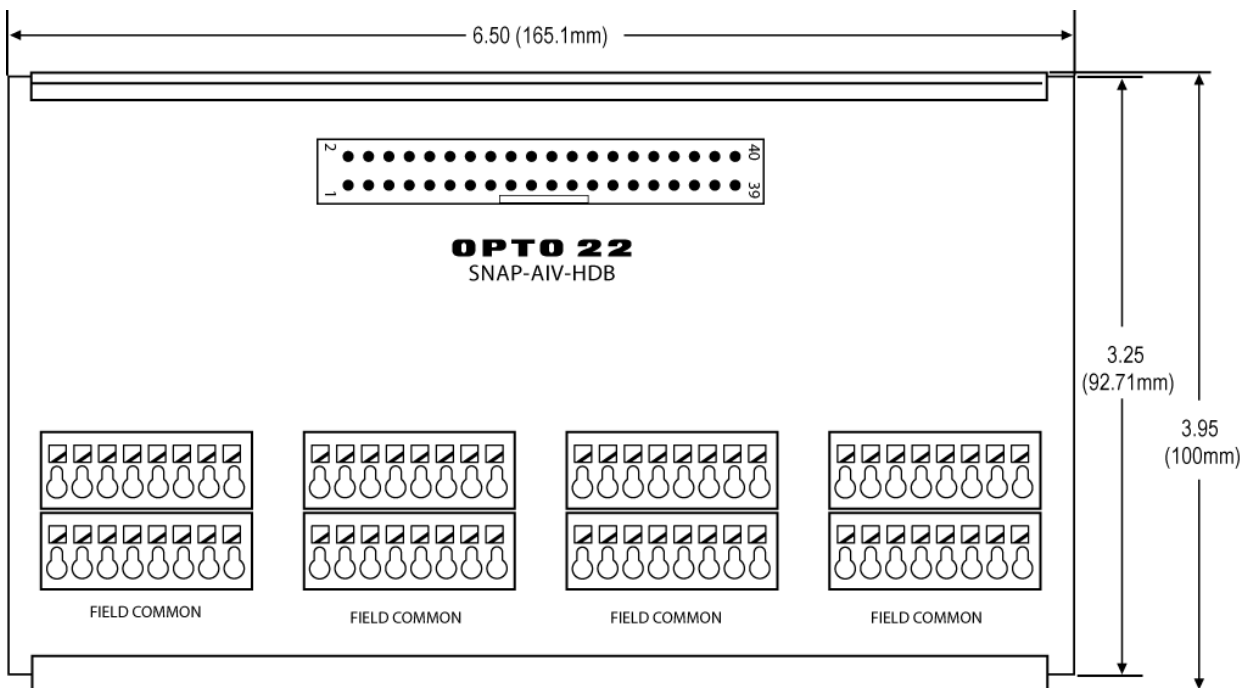

WIRING DIAGRAMS FOR CABLES AND BREAKOUT BOARDS

Module Type	To Breakout Board	See page
4-point digital modules	SNAP-TEX-32	25
	SNAP-TEX-FB16-H	26
	SNAP-TEX-FB16-L	
	SNAP-TEX-MR10-4	29
	SNAP-TEX-MR10-16	
	SNAP-TEX-MR10-16C	30
1-, 2-, or 4-point analog modules	SNAP-TEX-32	25
8-point analog output module	SNAP-TEX-32	32
16-point digital modules	SNAP-TEX-32	33
	SNAP-TEX-FB16-H	34
	SNAP-TEX-FB16-L	
	SNAP-TEX-MR10-16C	31
	No breakout board	35
32-point digital modules	SNAP-TEX-32	36
	SNAP-TEX-FB16-H	37
	SNAP-TEX-FB16-L	
32-point digital inputs or outputs	SNAP-UDC-HDB	38
32-point digital inputs or outputs to G4 I/O	SNAP-UDC-HDB-G4	41
32-point digital inputs	SNAP-IDC-HDB	43
32-point digital outputs	SNAP-ODC-HDB	46
32-point digital outputs (sourcing only)	SNAP-TEX-MR10-16	49
	SNAP-TEX-MR10-16C	50
32-point SNAP-AIMA-32	SNAP-AIMA-HDB	51
32-point SNAP-AIV-32	SNAP-AIV-HDB	52
32-point SNAP-AIV-32	SNAP-TEX-32	36

WIRING: 4-POINT DIGITAL OR ANALOG MODULE TO SNAP-TEX-32 BREAKOUT BOARD

Wire up to eight 4-point modules to the SNAP-TEX-32. Only one module is shown below.

Cable:

SNAP-TEX-CBO6
SNAP-TEX-CBE6
SNAP-TEX-CBS6
Find the appropriate cable for your module in the tables starting on [page 2](#).

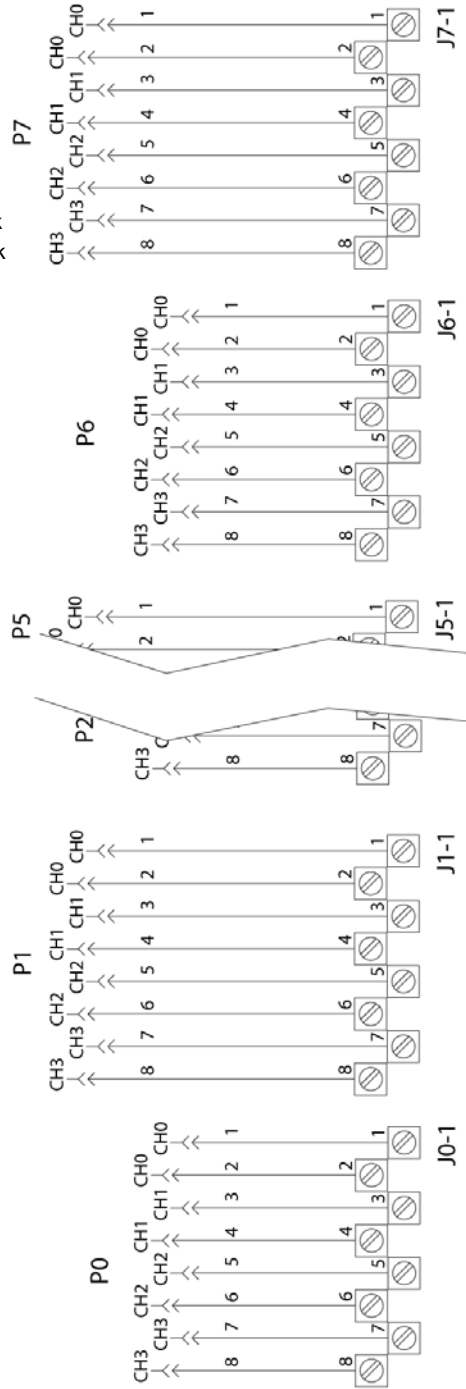
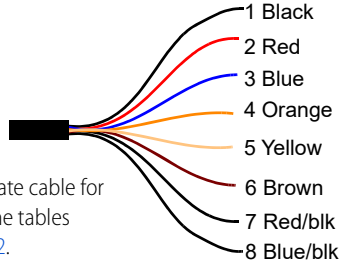

**SNAP-TEX-32
breakout board**

For field wiring, see the data sheet for the module you are using.

WIRING: 4-POINT DIGITAL MODULE TO SNAP-TEX-FB16-H OR SNAP-TEX-FB16-L BOARD

General Instructions

SNAP-TEX-FB16-H or SNAP-TEX-FB16-L breakout board

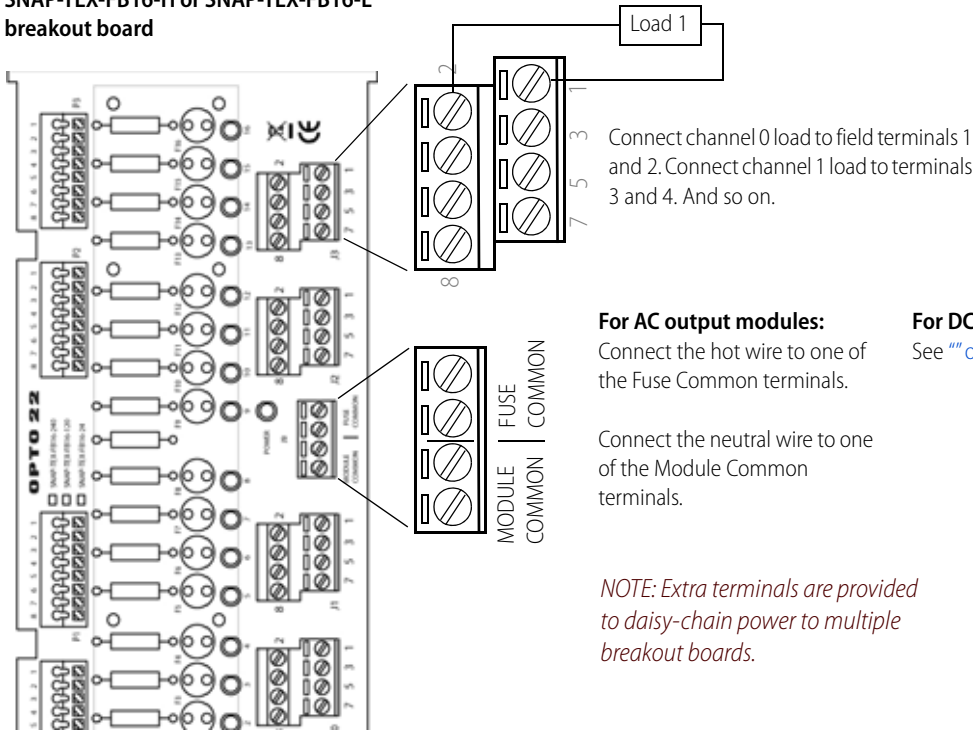

SNAP-TEX-FB16-H or SNAP-TEX-FB16-L breakout board

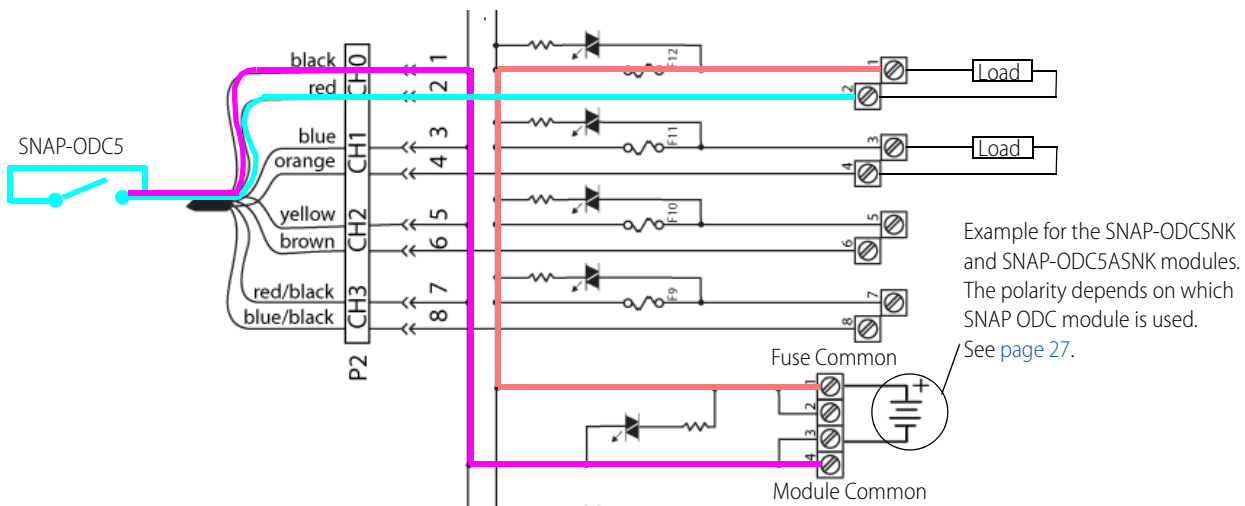

4-POINT DIGITAL MODULE TO SNAP-TEX-FB16-H OR SNAP-TEX-FB16-L (CONTINUED)

Polarity and Module Type

When using DC output modules, the polarity for connecting the DC power source to the Module Common and Fuse Common terminals on the breakout board depends on the SNAP digital output module being used.

The SNAP-TEX-FB16-H and SNAP-TEX-FB16-L breakout boards use the Module Common to connect to all the odd terminals of the SNAP output module.

Fuse Common goes to the individual fuses, which go to the odd terminals on this breakout board.

The even terminals on the SNAP output modules go to the even terminals via the SNAP-TEX cable.

SNAP-ODC5SNK, SNAP-ODC5ASNK

These modules internally tie all odd terminals together.

- Connect the positive side of the DC power source to Fuse Common.
- Connect the negative side of the DC power source to Module Common.

SNAP-ODC5SRC

This module internally ties all even terminals together.

- Connect the positive side of the DC power source to Module Common.
- Connect the negative side of the DC power source to Fuse Common.

SNAP-ODC5MA, SNAP-ODC5-i, SNAP-ODC5A-i

IMPORTANT: The points on these modules are isolated from each other. However, when used with this breakout board, the channel-to-channel isolation is bypassed, because this breakout board ties the module's odd terminals together.

- Connect the positive side of the DC power source to Module Common.
- Connect the negative side of the DC power source to Fuse Common.

4-POINT DIGITAL MODULE TO SNAP-TEX-FB16-H OR SNAP-TEX-FB16-L (CONTINUED)

CAUTION: Do NOT use the SNAP-TEX-CBE6 (even pins commoned) cable with this board. The board has odd pins commoned.

Cable:
SNAP-TEX-CB06
SNAP-TEX-CBS6
Find the appropriate cable for your module in the tables starting on page 2.

Also see "General Instructions" on page 26.

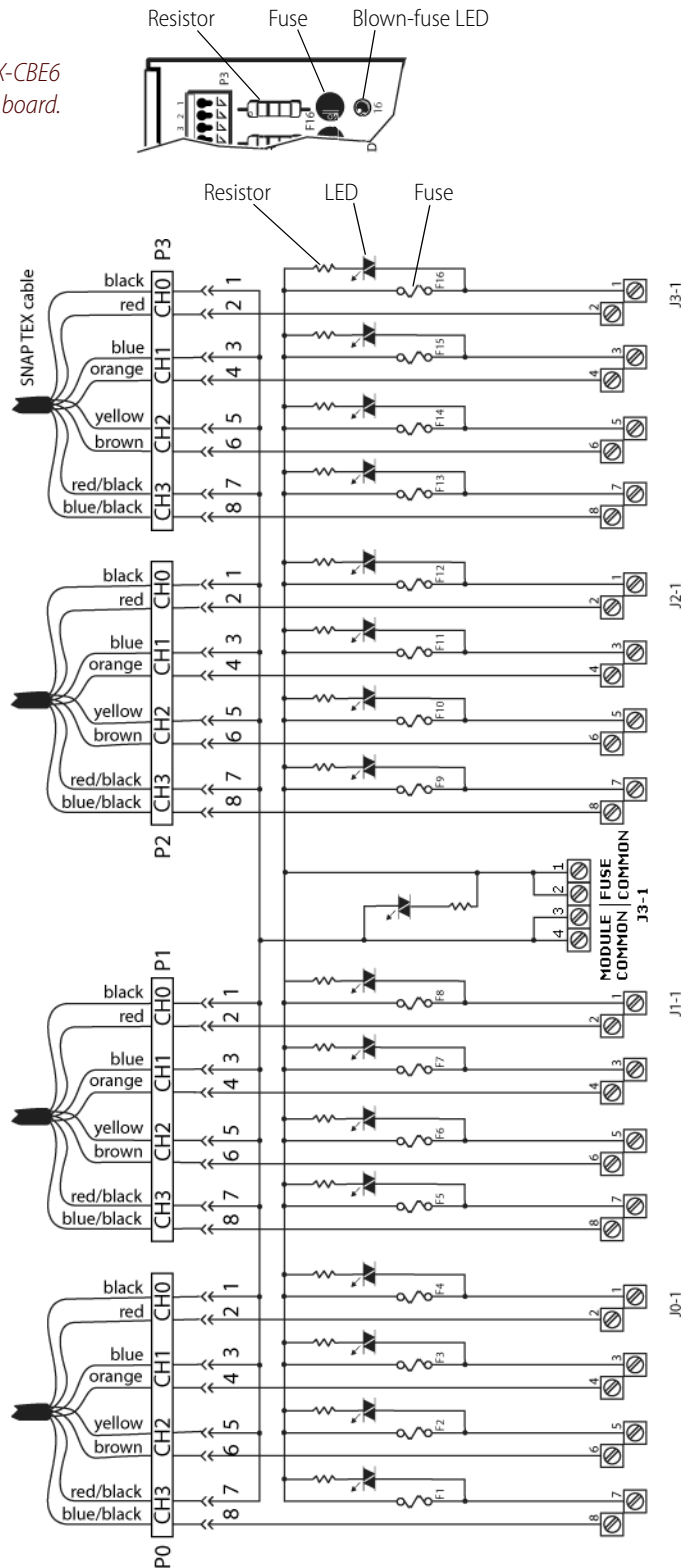

WIRING: 4-POINT DIGITAL MODULE TO SNAP-TEX-MR10-4 OR SNAP-TEX-MR10-16 BOARD

The example shows wiring for the first two points on a SNAP-ODC5-i module to a SNAP-TEX-MR10-4 board. Wiring connections shown are for a SNAP-TEX-CBO6 cable.

Wiring 4-point modules to a SNAP-TEX-MR10-16 board is similar. The MR10-16 has 16 channels rather than four.

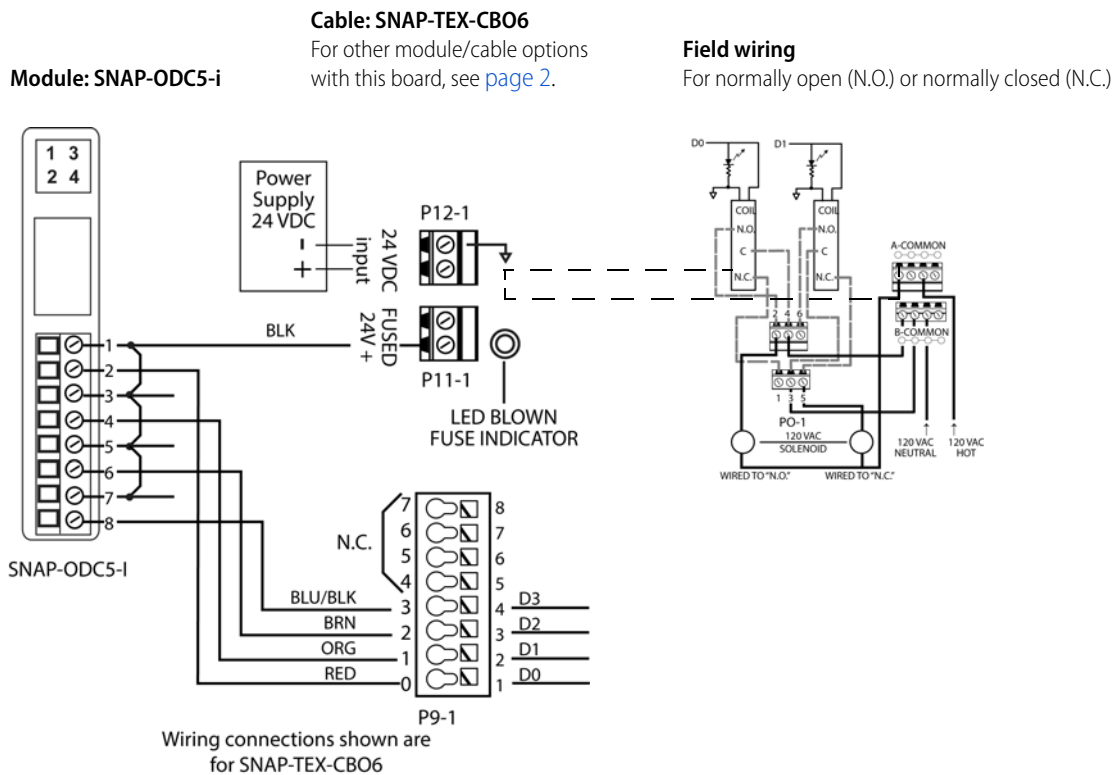

NOTE: Transient protection must be used on inductive loads.

WIRING: 4-POINT DIGITAL OUTPUT MODULE TO SNAP-TEX-MR10-16C BOARD

Two 4-point ODC modules can be wired to each of the two spring connectors.

The example shows the first two points on a SNAP-ODC5-i module.

Wiring connections shown are for a SNAP-TEX-CBO6 cable.

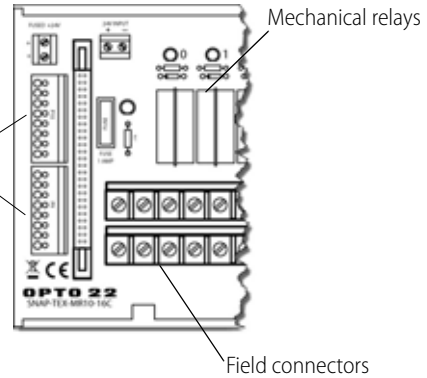

Cable: SNAP-TEX-CBO6

For other module/cable options with this board, see [page 2](#).

Module: SNAP-ODC5-i

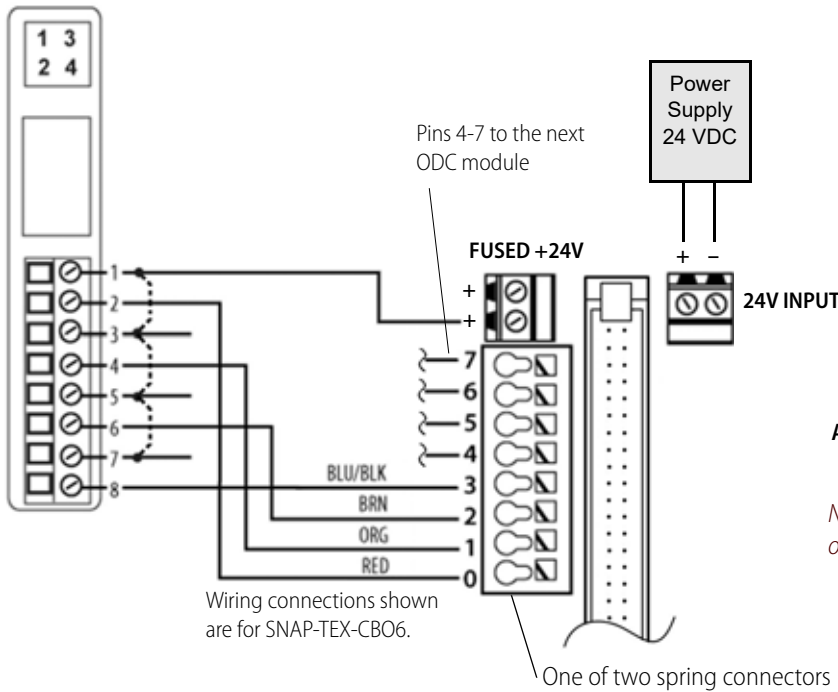

Also see next page.

NOTE: Transient protection must be used on inductive loads.

NOTE: If you are using a SNAP-TEX-CBS6 cable instead of the SNAP-TEX-CBO6, jumpers are required for a SNAP-ODC5-I module. They are not required for a SNAP-ODC5SRC module.

4-PT OR 16-PT DIGITAL OUTPUT MODULE TO SNAP-TEX-MR10-16C

SNAP-TEX-MR10-16C Relay Group

The diagram below shows relays 0 and 1 in a relay group.

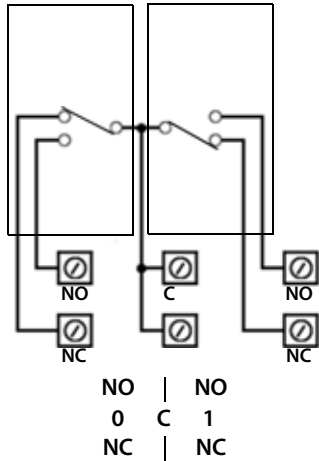

Terminals 0 and 1

NOTE: The diagrams on this page apply to the SNAP-TEX-MR10-16C breakout board used with either a 4-point digital output module or a 16-point digital output module.

NOTE: Transient protection must be used on inductive loads.

Jumper Straps—SNAP-TEX-MR10-16C Breakout Board

This diagram shows an example using jumper straps, Opto 22 part numbers STRAP2Q and STRAP4Q.

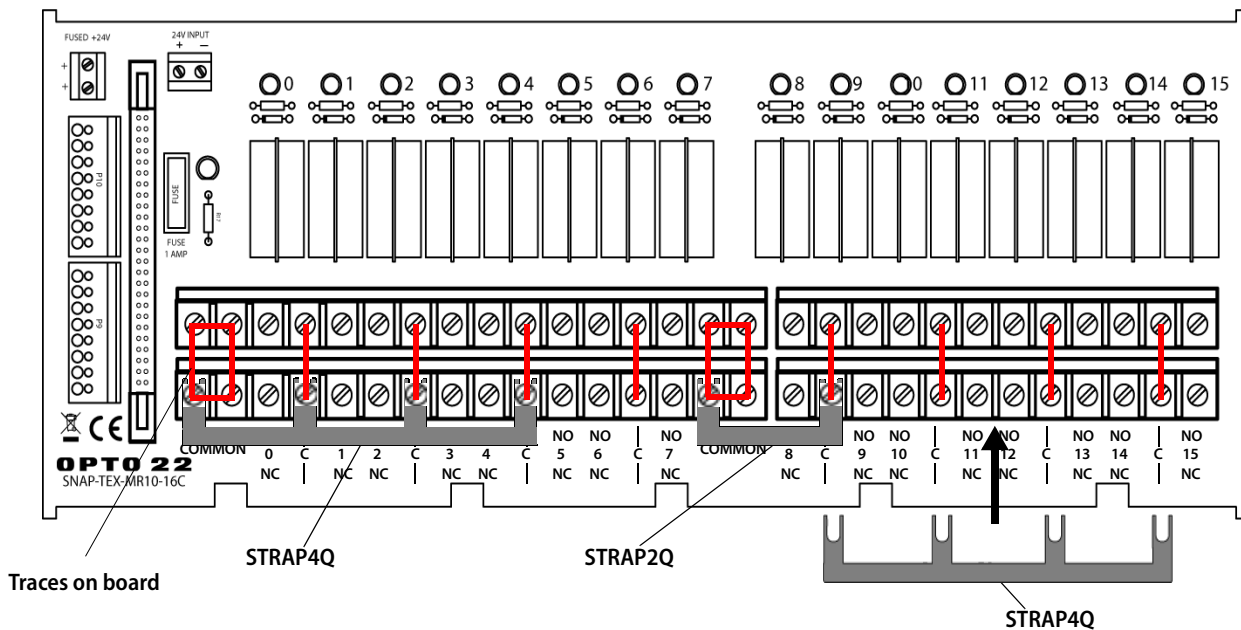

WIRING: 8-POINT ANALOG OUTPUT MODULE TO SNAP-TEX-32 BREAKOUT BOARD

Use up to four 8-point SNAP-AOVA-8 analog output modules per board.
Use cable SNAP-HD-20F6. Wiring example for one module is shown below.

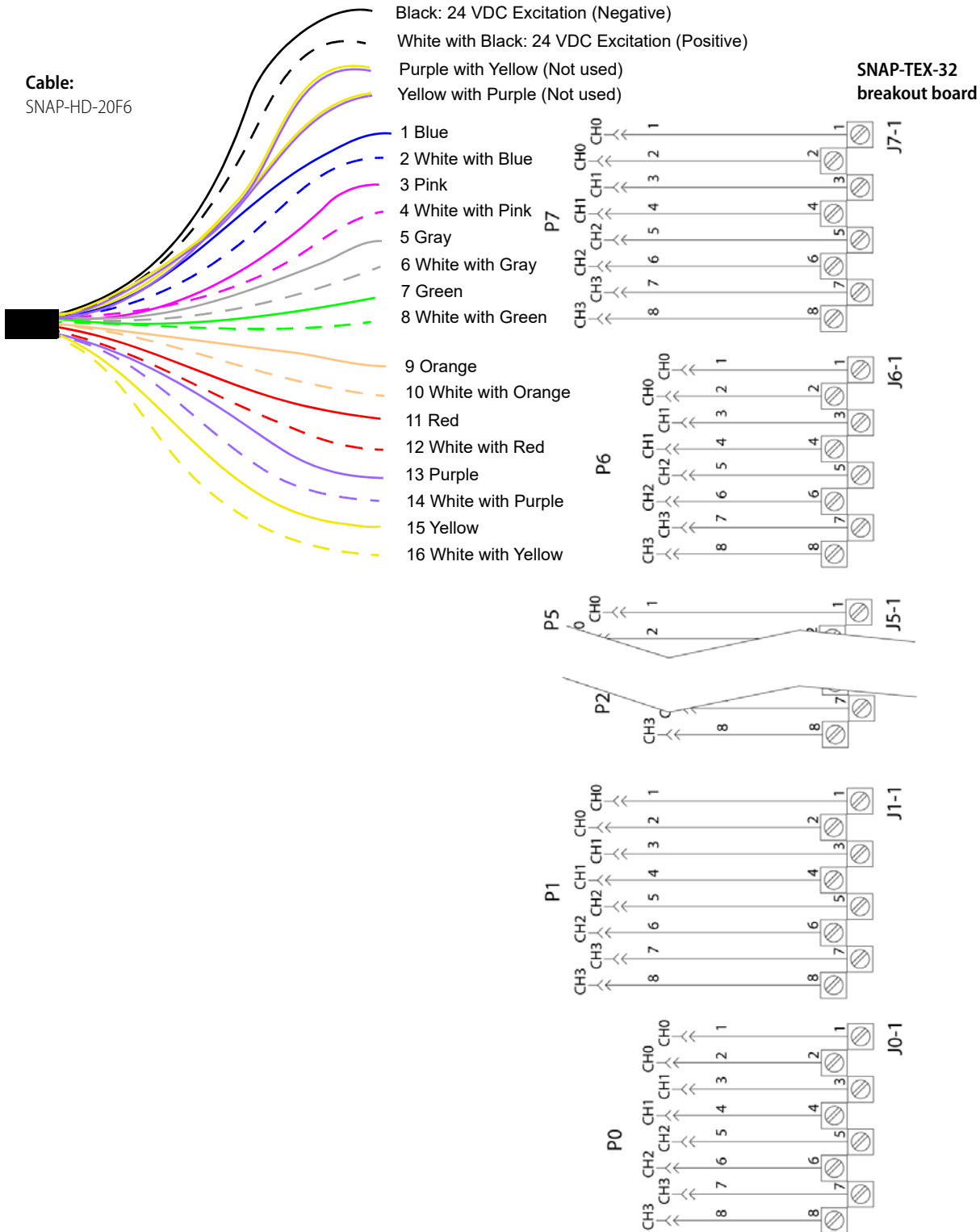

WIRING: 16-POINT DIGITAL MODULE TO SNAP-TEX-32 BREAKOUT BOARD

Use two modules per board. The SNAP-HD-ACF6 cable assembly includes two identical cables, each with a 16-pin connector. It takes both cables to cover one module.

Wiring for one cable is shown in the diagram below. Field connection wires are twisted pair.

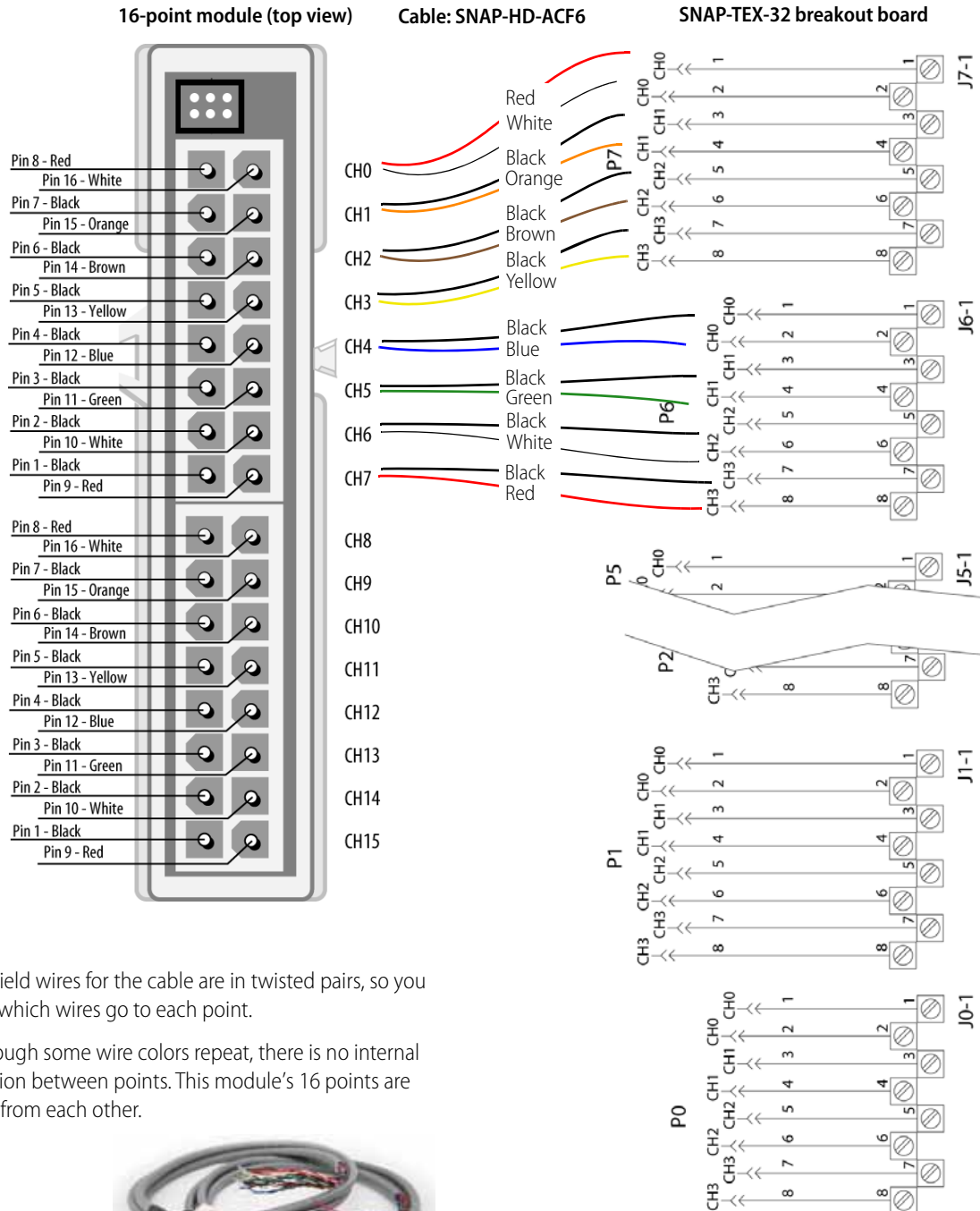

NOTE: Field wires for the cable are in twisted pairs, so you can see which wires go to each point.

Even though some wire colors repeat, there is no internal connection between points. This module's 16 points are isolated from each other.



WIRING: 16-POINT DIGITAL INPUT MODULE TO SNAP-TEX-FB16-H OR SNAP-TEX-FB16-L

Note: When using a breakout board, each connector will have six unused wires (5 Black and 1 Red).

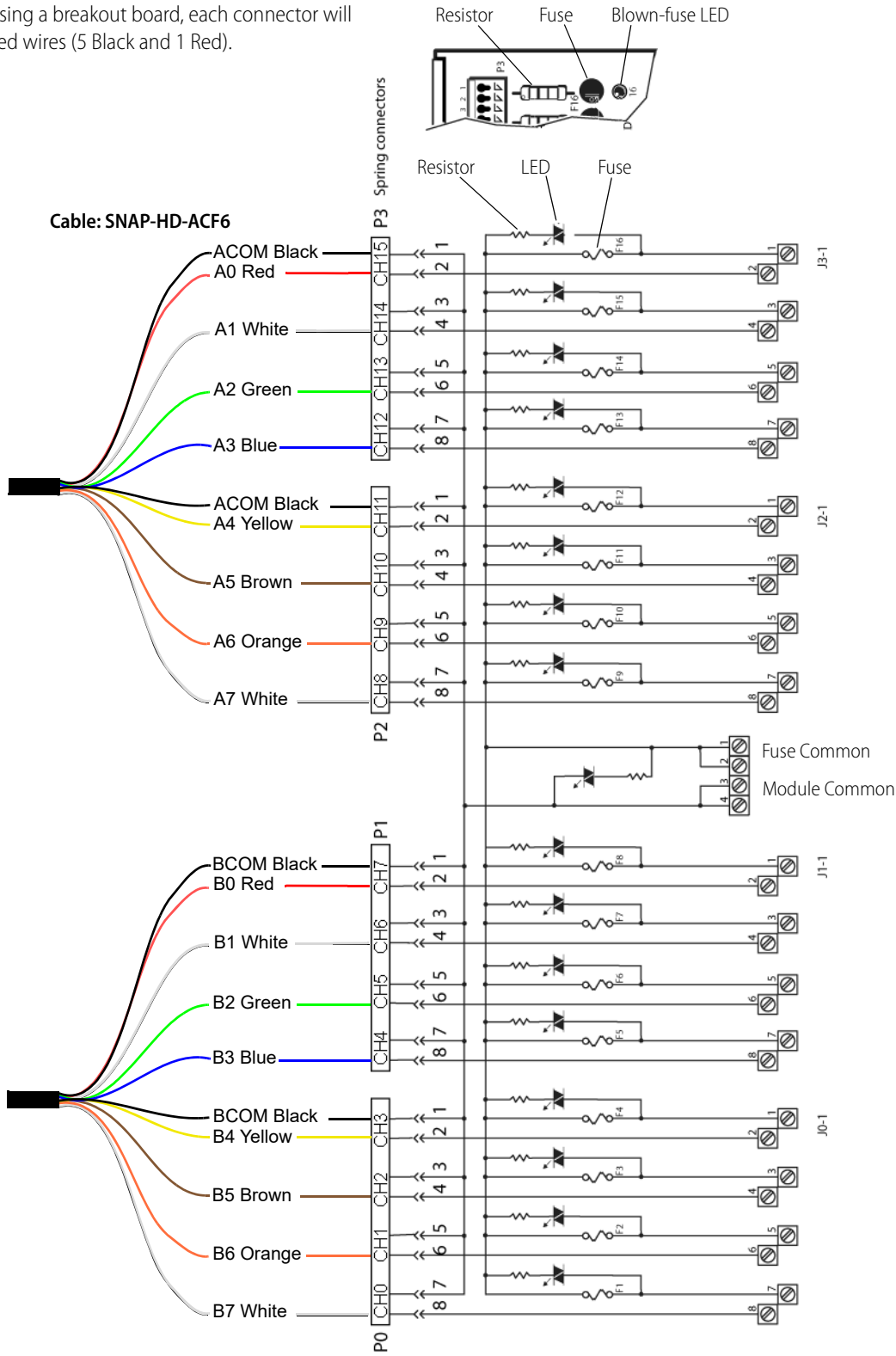

WIRING: 16-POINT DIGITAL INPUT MODULE TO FIELD DEVICES (NO BREAKOUT BOARD)

The following diagrams show wiring from the SNAP-HD-ACF6 cable to a 16-channel module (left) and pinouts to field devices (right). The small six-pin connector on the top of the module connects to the optional OptoTerminal-G20 using a special adapter cable, included with the OptoTerminal.

Cable: SNAP-HD-ACF6

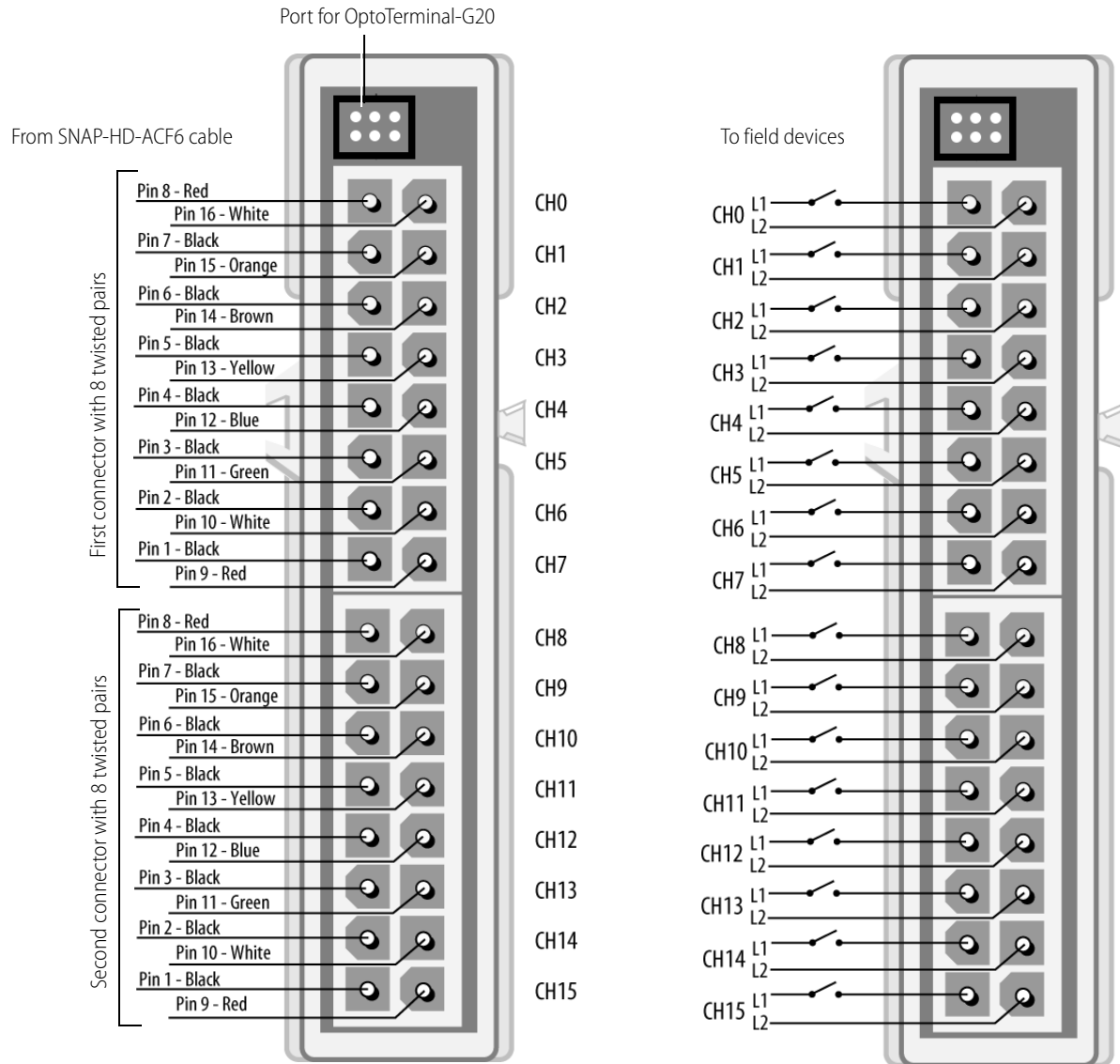

NOTE: The connectors on these modules are not polarity-specific. You can connect the positive lead (+) for each channel (or point) to either L1 or L2, and this can vary from point to point on the module.

WIRING: 32-POINT DIGITAL MODULE TO SNAP-TEX-32 BREAKOUT BOARD

SNAP-HD-CBF6 Cable Wiring

The following table shows connector wiring for the SNAP-HD-CBF6.

Wires from the cable are grouped into four sets.

Set A			Set B			Set C			Set D		
Wires		Point	Wires		Point	Wires		Point	Wires		Point
A0	Gray	0	B0	Gray	8	C0	Gray	16	D0	Gray	24
A1	Blue	1	B1	Blue	9	C1	Blue	17	D1	Blue	25
A2	Yellow	2	B2	Yellow	10	C2	Yellow	18	D2	Yellow	26
A3	Red	3	B3	Red	11	C3	Red	19	D3	Red	27
A4	White	4	B4	White	12	C4	White	20	D4	White	28
A5	Violet	5	B5	Violet	13	C5	Violet	21	D5	Violet	29
A6	Green	6	B6	Green	14	C6	Green	22	D6	Green	30
A7	Orange	7	B7	Orange	15	C7	Orange	23	D7	Orange	31
ACOM	Blk/Brn	com	BCOM	Blk/Brn	com	CCOM	Blk/Brn	com	DCOM	Blk/Brn	com

The four sets relate to point numbers on the module as shown below.

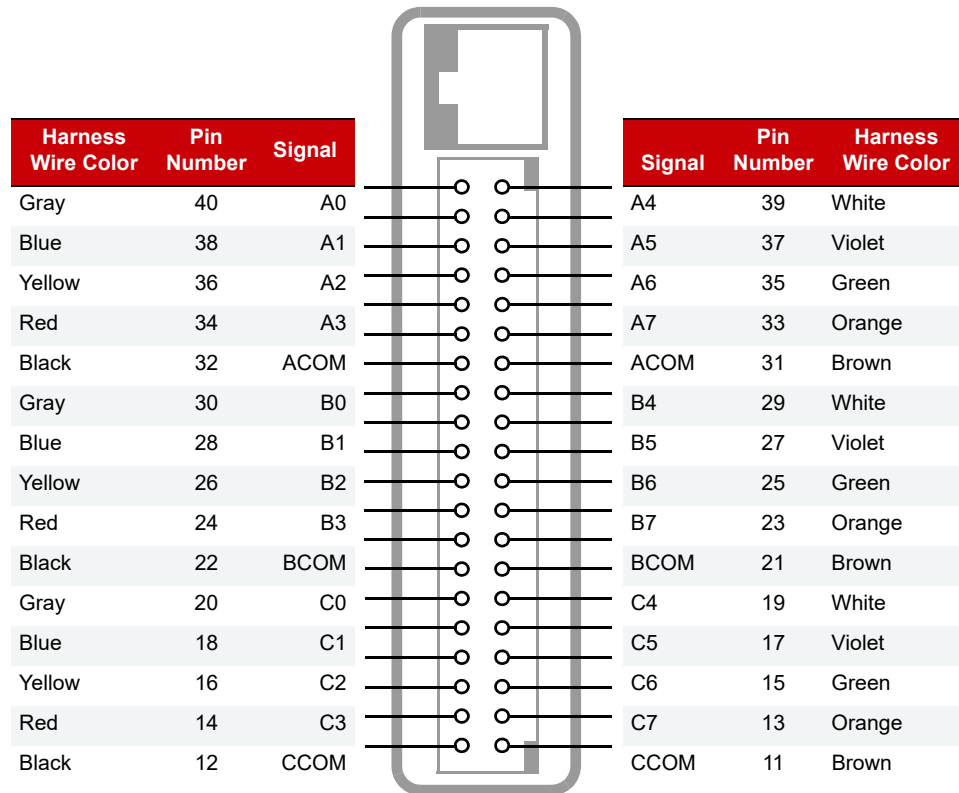

Connector wiring for SNAP-ODC-32-SNK, SNAP-ODC-32-SRC, SNAP-IDC-32, -FM versions, SNAP-IDC-32N, and SNAP-IDC-32DN (top view of module)

WIRING: 32-POINT DIGITAL OUTPUT MODULE TO SNAP-TEX-FB16-H OR SNAP-TEX-FB16-L

From SNAP-ODC-32-SRC or SNAP-ODC-32-SNK digital output module. Use two boards per module.

See tables on [page 36](#).

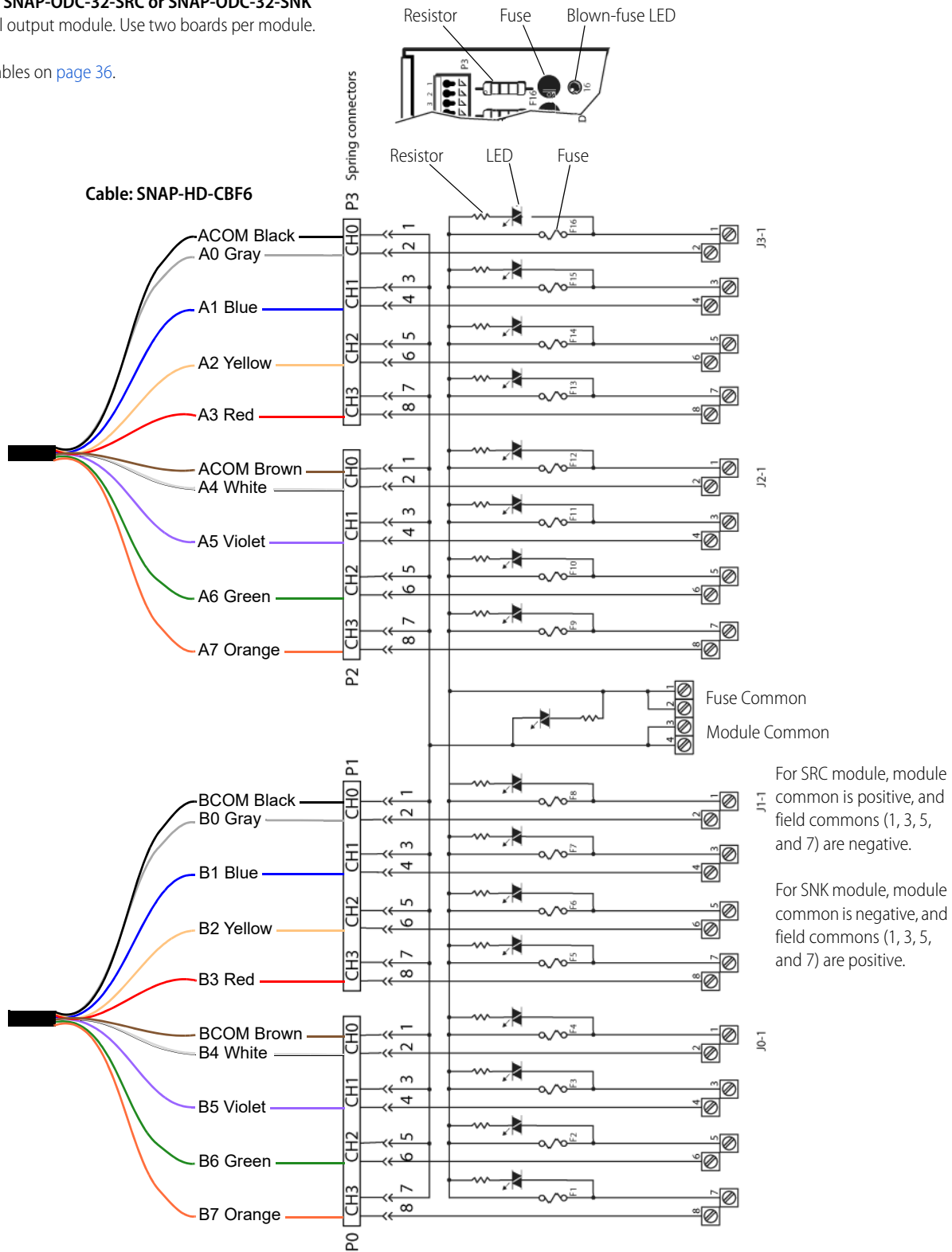

WIRING: 32-POINT DIGITAL INPUT OR OUTPUT MODULE TO SNAP-UDC-HDB BOARD

SNAP-HD-BF6 cable

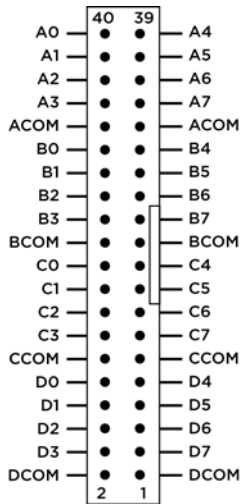

Run a SNAP-HD-BF6 cable from the top of the SNAP 32-point module to the 40-pin connector on the breakout board.

Note that points on the cable are in four groups of eight points: A0–A7, B0–B7, C0–C7, and D0–D7. These correspond to the groups of spring-clamp connectors on the breakout board, as shown below.

For all spring clamp connectors: Insert a small standard screwdriver into the top of the small hole and push the handle away from you so that the larger hole below opens. Insert the wire into the larger hole and remove the screwdriver.

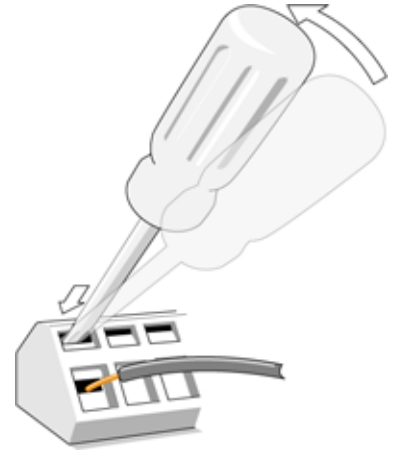

40-pin connector

Jumpers:

- For input modules, set all four jumpers (JP1–JP4) to the X position.
- For output modules, set all four jumpers to the Z position.

Field wiring for group A:

Points A0–A7

Module common (group A)

Field common (group A)

WIRING: 32-POINT DIGITAL INPUT MODULES TO SNAP-UDC-HDB BOARD

SNAP-IDC-32, SNAP-IDC-32FM, and SNAP-IDC-32D

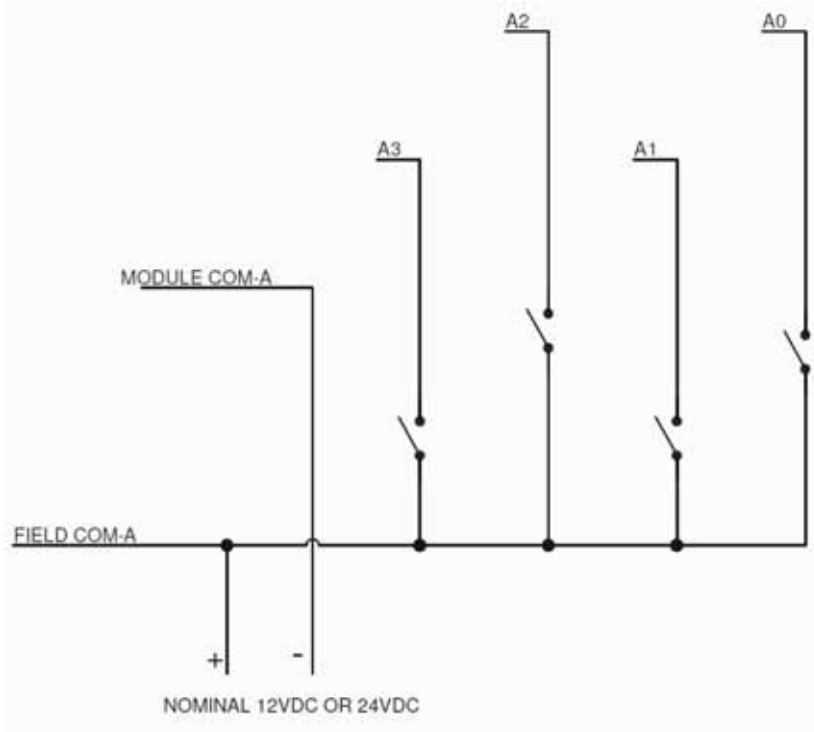

Jumpers: For input modules, set all four jumpers to the X position.

SNAP-IDC-32N and SNAP-IDC-32DN

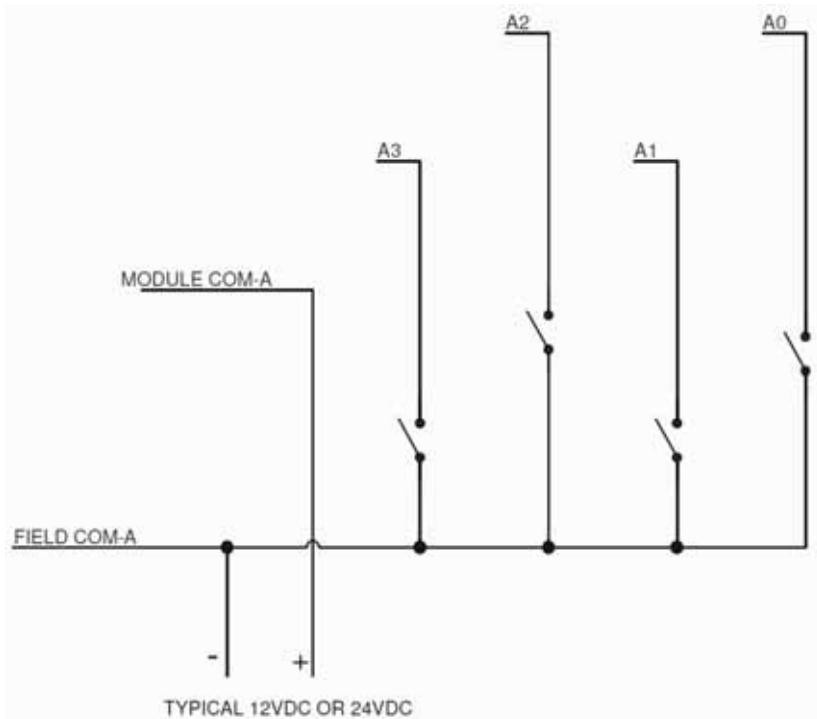

Jumpers: For input modules, set all four jumpers to the X position.

WIRING: 32-POINT DIGITAL OUTPUT MODULES TO SNAP-UDC-HDB BOARD

SNAP-ODC-32-SNK and SNAP-ODC-32-SNK-FM

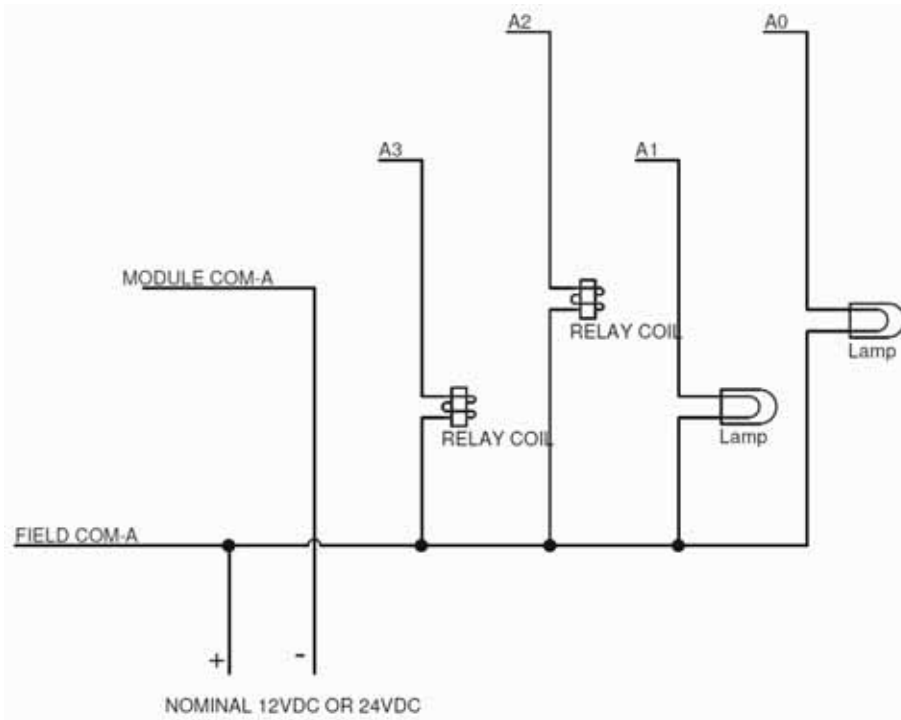

Jumpers: For output modules, set all four jumpers to the Z position.

All groups must be fused. Either fuse each point or fuse each group of points (for example, Group A or Group B).

SNAP-ODC-32-SRC and SNAP-ODC-32-SRC-FM

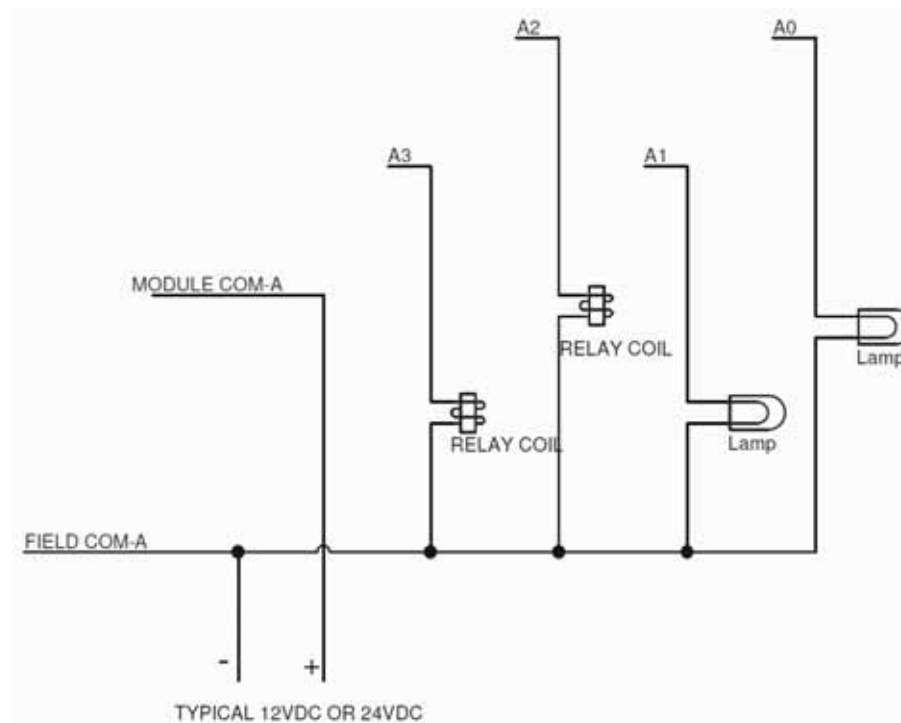

Jumpers: For output modules, set all four jumpers to the Z position.

All groups must be fused. Either fuse each point or fuse each group of points (for example, Group A or Group B).

WIRING: 32-POINT DIGITAL INPUT OR OUTPUT MODULE TO SNAP-UDC-HDB-G4 BOARD

Because the SNAP-UDC-HDB-G4 can accommodate a variety of G4 digital input and output modules, wiring depends on the modules you are using. G4 modules on the board can be a mix of AC and DC, but they must be all inputs or all outputs and must have the same logic voltage (all 5 V, or all 15 V, or all 24 V).

Use the SNAP 32-point module and jumper setting to match your G4 modules:

G4 module type	Voltage	Use this SNAP module...	Set JP1 to...
Outputs (must all be same logic voltage)	5 V, 15 V, or 24 V	SNAP-ODC-32-SNK SNAP-ODC-32-SNK-FM	LOGIC –
Inputs (must all be same logic voltage)	5 V	SNAP-IDC-32DN	LOGIC +
	15 V or 24 V	SNAP-IDC-32N	LOGIC +

Use a SNAP-HD-BF6 cable to connect the SNAP module to the board.

For all spring clamp connectors: Insert a small standard screwdriver into the top of the small hole and push the handle away from you so that the larger hole below opens. Insert the wire into the larger hole and remove the screwdriver. See next page for diagram.

All G4 modules you mount on the rack must be of the same voltage: 5 V, 15 V, or 24 V.
Apply logic voltage to the rack according to the modules on it. For example, if you are using 5 V G4 modules, apply 5 VDC to the rack.
Wire incoming logic voltage to one plus and one minus (it doesn't matter which one). The second pair is available if you want to daisy chain racks.

For each G4 module, wire field devices to the corresponding A and B connectors. For example, wire the module in the A0 position to the connectors marked A0 A and B. See field wiring diagrams on the next page.

Run a SNAP-HD-BF6 cable from the top of the SNAP module to the 40-pin connector on the board.

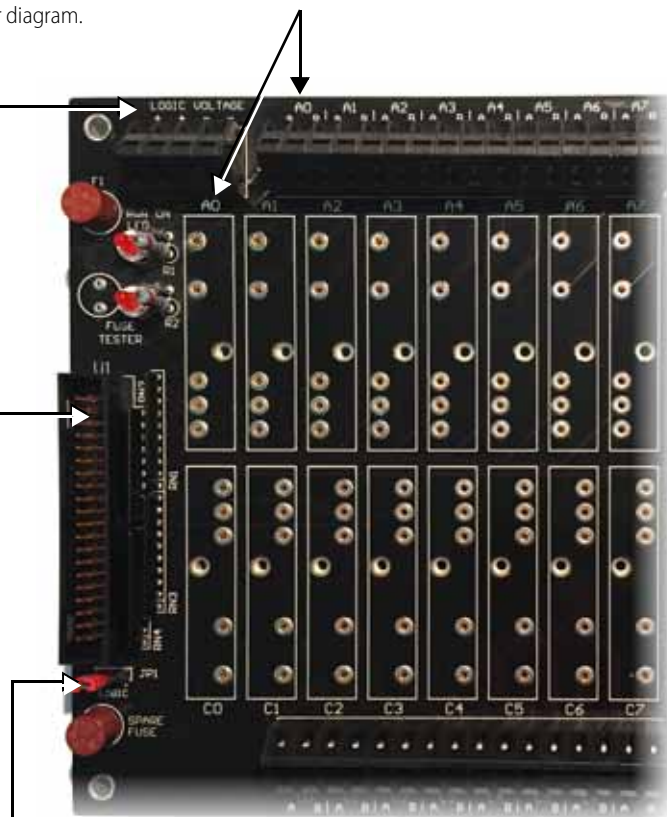
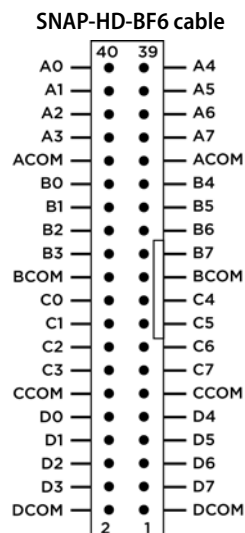

Remember to set jumper 1 (JP1) to match the G4 modules you use:
- For output modules, set JP1 to LOGIC –.
- For input modules, set JP1 to LOGIC +.

WIRING: 32-POINT DIGITAL INPUT OR OUTPUT MODULE TO SNAP-UDC-HDB-G4 (CONTINUED)

Field wiring for G4 modules on the SNAP-UDC-HDB-G4

Input modules using DC field voltages

G4IDC5 G4IDC5G G4IAC5
G4IDC5B G4IDC5K G4IAC5A
G4IDC5D G4IDC5MA G4IAC5M

These AC input modules work with either AC or DC field voltages. For DC voltages, use the diagram at right. For AC field voltages, use the diagram below.

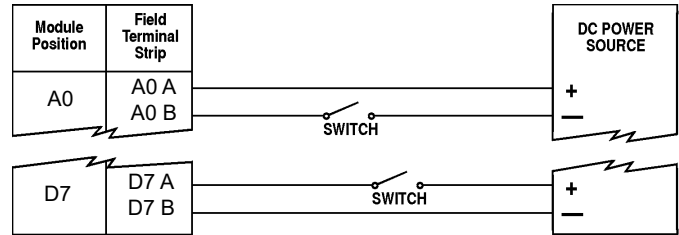

Input modules using AC field voltages

G4IAC5 G4IDC5
G4IAC5A G4IDC5G
G4IAC5MA G4IDC5MA

These DC input modules work with either DC or AC field voltages. For AC voltages, use the diagram at right. For DC field voltages, use the diagram above.

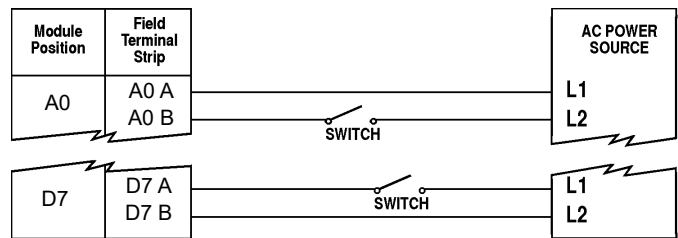

Output modules using DC field voltages

G4ODC5
G4ODC5A
G4ODC5MA

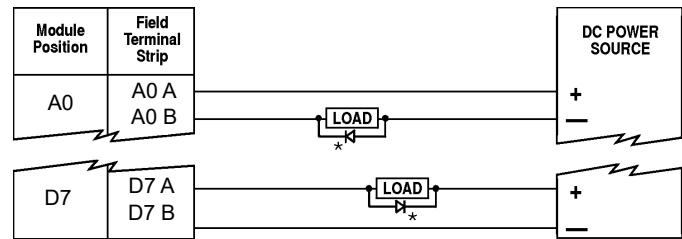

*Note: Commutation diode must be used on inductive loads. Typically, use diode 1N4005

Output modules using AC field voltages

G4OAC5 G4OAC5MA
G4OAC5A G4OAC5AMA
G4OAC5A5

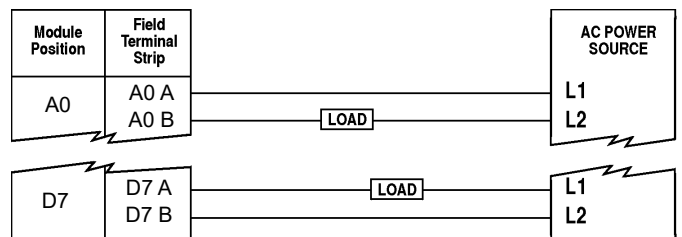

For all spring clamp connectors: Insert a small standard screwdriver into the top of the small hole and push the handle away from you so that the larger hole below opens. Insert the wire into the larger hole and remove the screwdriver.

WIRING: 32-POINT DIGITAL INPUT MODULE TO SNAP-IDC-HDB BOARD

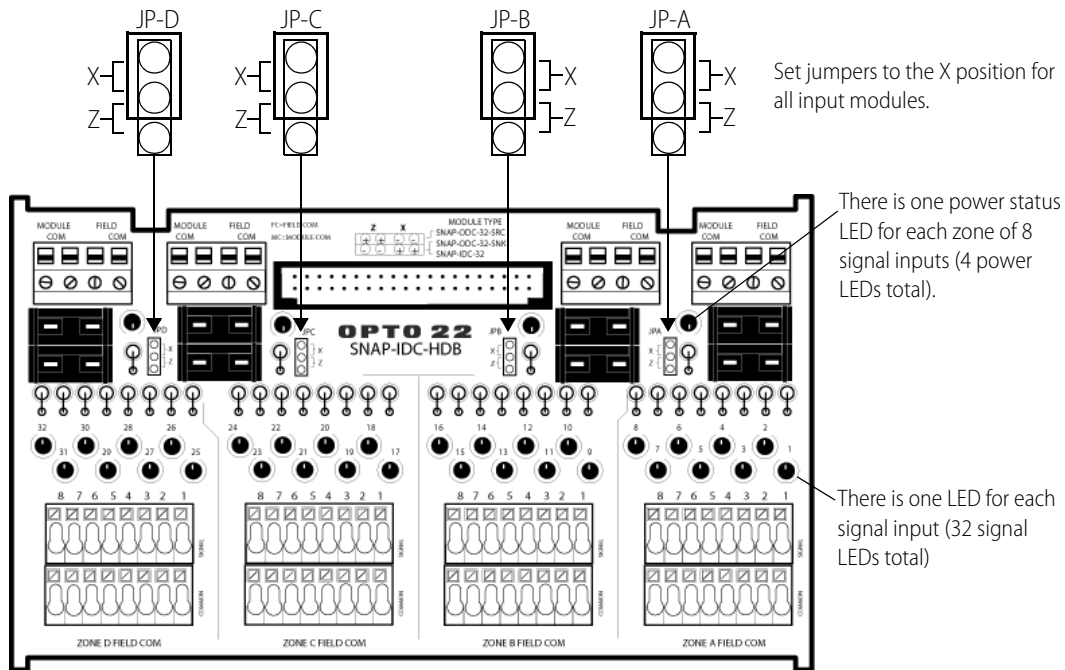

Set jumpers to the X position for all input modules.

There is one power status LED for each zone of 8 signal inputs (4 power LEDs total).

There is one LED for each signal input (32 signal LEDs total)

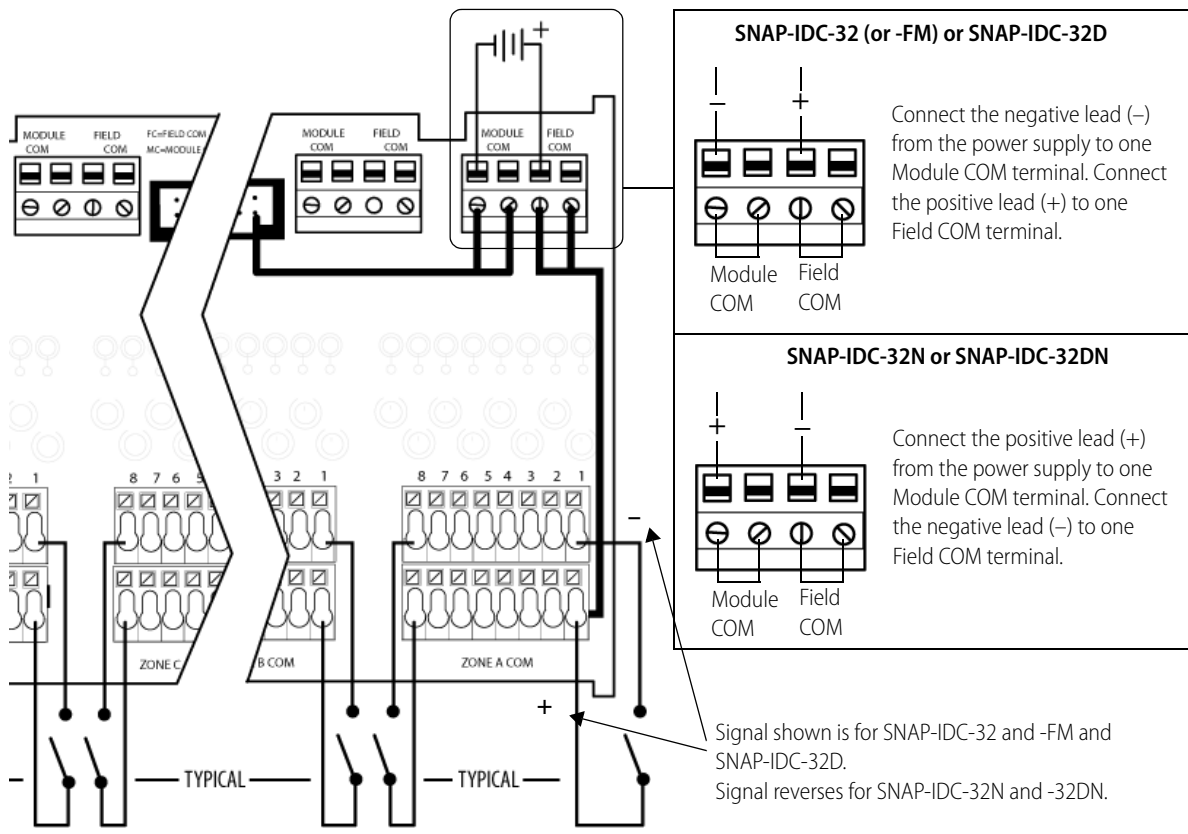

32-POINT DIGITAL INPUT MODULE TO SNAP-IDC-HDB (CONTINUED)

Modules—this diagram applies to:
SNAP-IDC-32
SNAP-IDC-32-FM
SNAP-IDC-32N

IMPORTANT: All SNAP-IDC-32 modules are polarity specific and must be wired as shown.

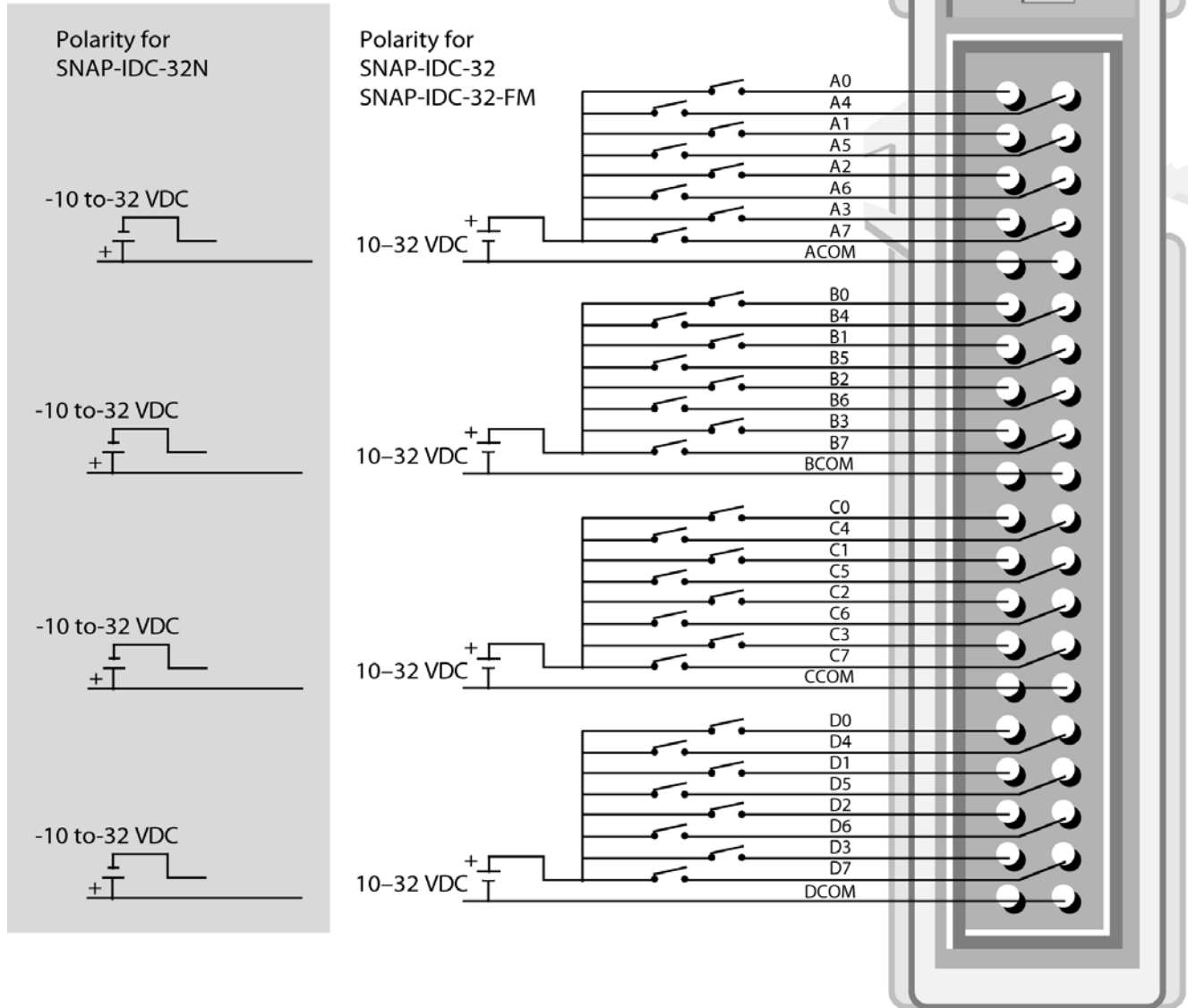

32-POINT DIGITAL INPUT MODULE TO SNAP-IDC-HDB (CONTINUED)

Modules—this diagram applies to:

SNAP-IDC-32-D

SNAP-IDC-32-DN

IMPORTANT: All SNAP-IDC-32 modules are polarity specific and must be wired as shown.

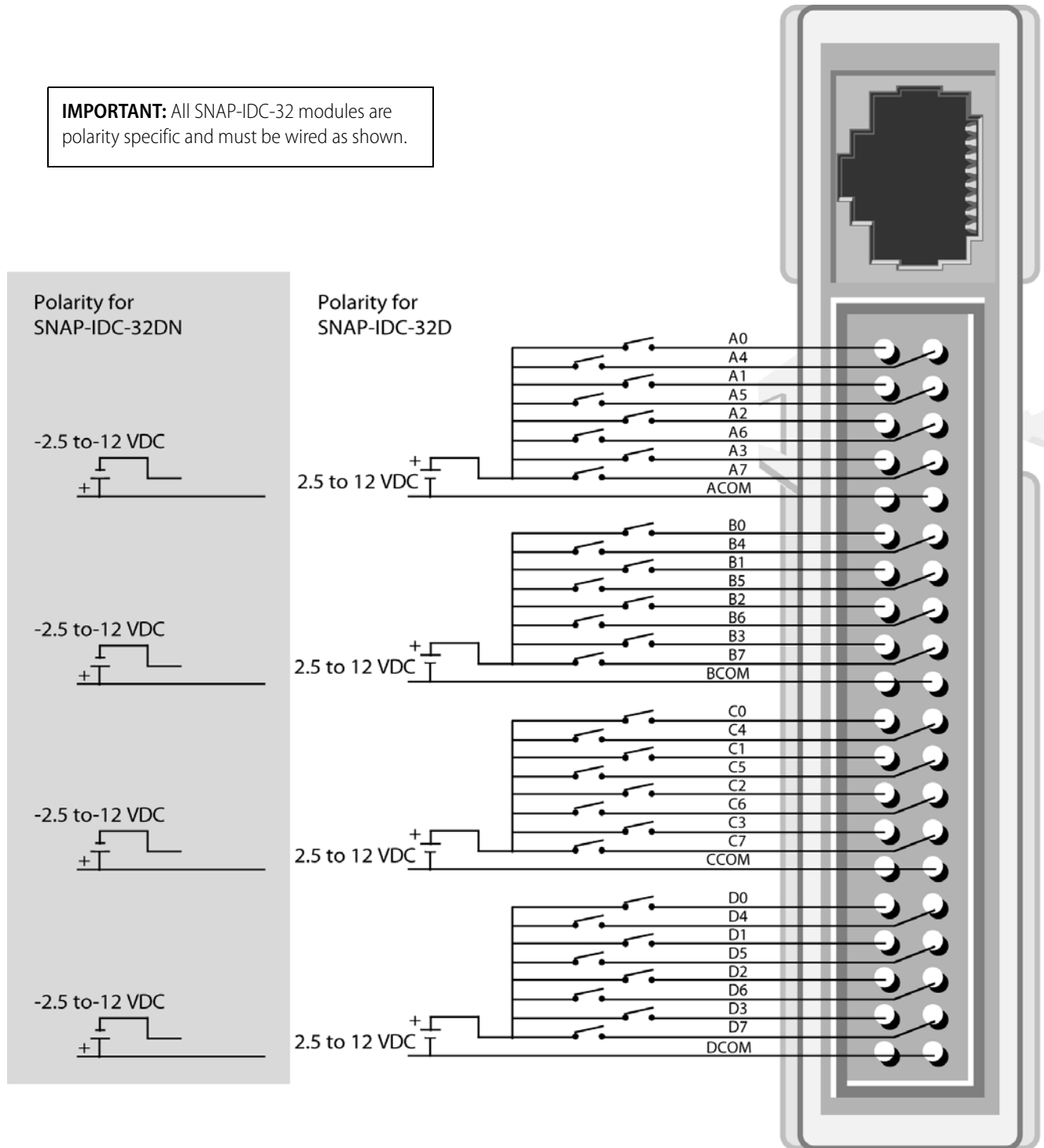

WIRING: 32-POINT DIGITAL OUTPUT MODULE TO SNAP-ODC-HDB BOARD

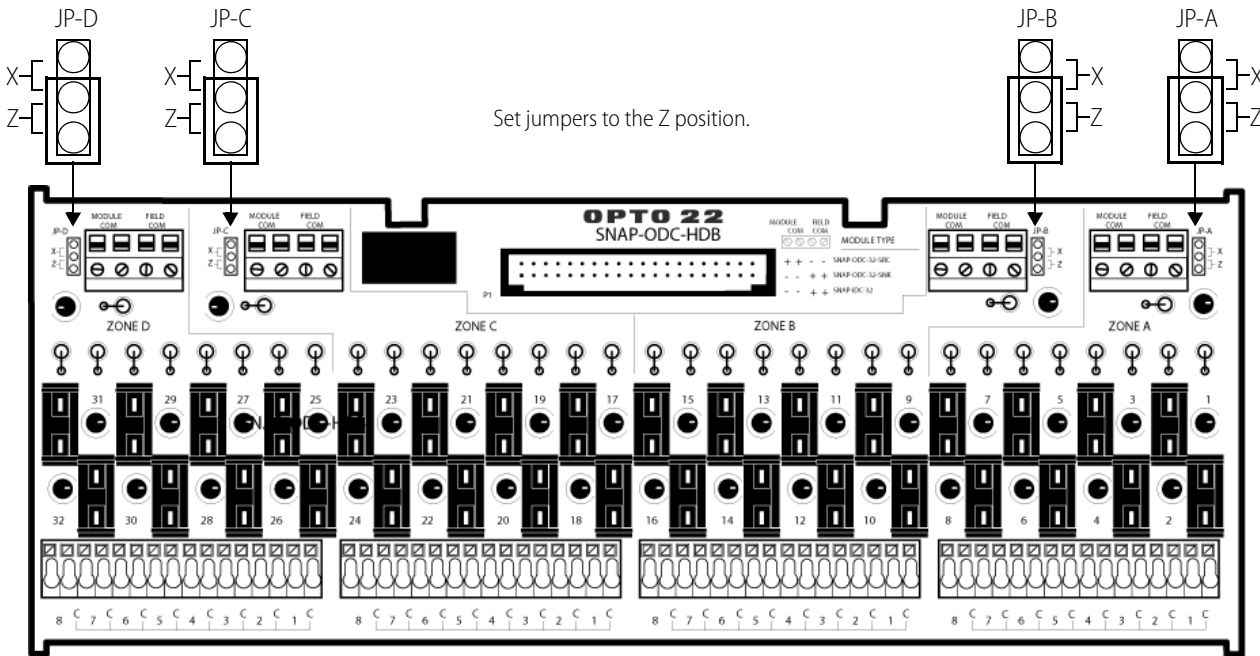

Power Supply Connections

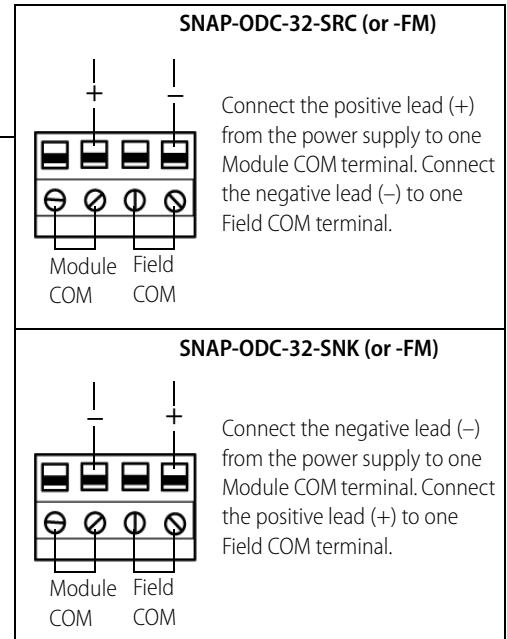
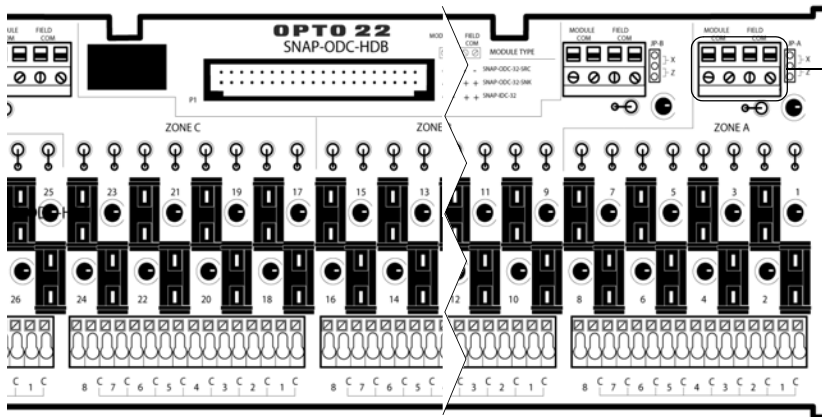

32-POINT DIGITAL OUTPUT MODULE TO SNAP-ODC-HDB (CONTINUED)

Field Connections

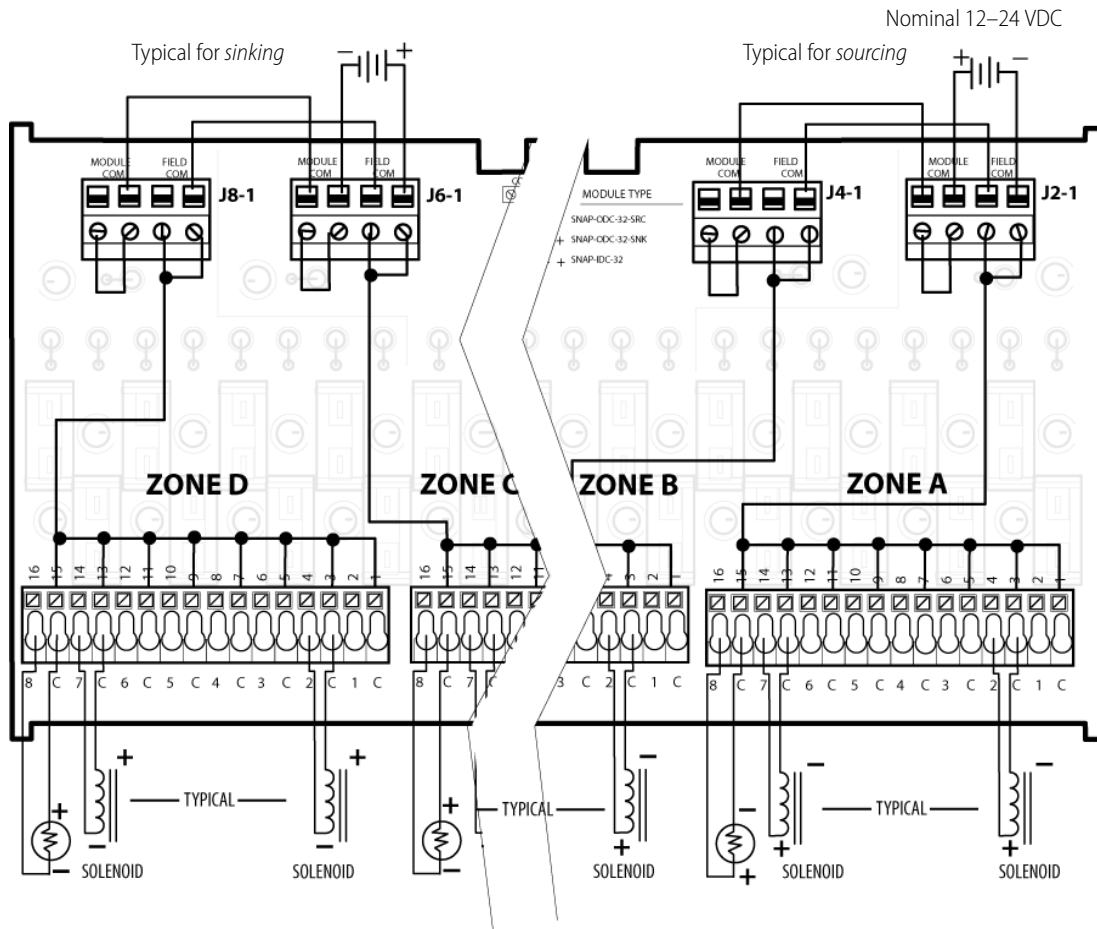

32-POINT DIGITAL OUTPUT MODULE TO SNAP-ODC-HDB (CONTINUED)

FUSING

For both sourcing and sinking modules, either fuse each point (as shown in the first and third groups, below) or fuse each group of points (as shown in the second and fourth groups).

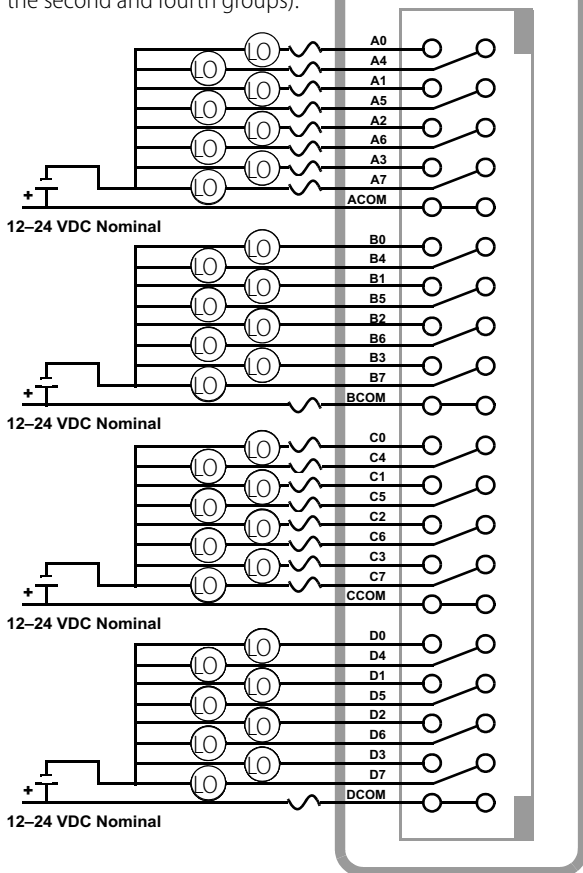

SNAP-ODC-32-SRC
Load Sourcing Module
(Top view of module)

All groups must be fused.

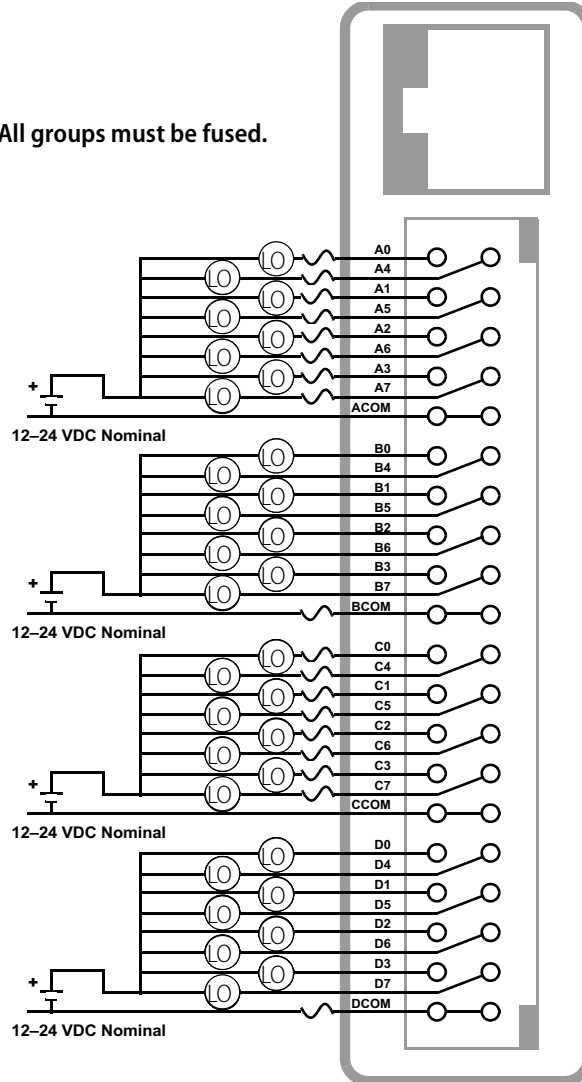

SNAP-ODC-32-SNK
Load Sinking Module
(Top view of module)

WIRING: 32-POINT DIGITAL OUTPUT MODULE TO SNAP-TEX-MR10-16 BOARD



For 32-point sourcing modules only (SNAP-ODC-32-SRC or SNAP-ODC-32-SRC-FM).
Use two breakout boards with one module and one SNAP-HD-CBF6 cable.

SNAP-TEX-MR10-16 breakout board

Two breakout boards are required for the 32 points on the module.

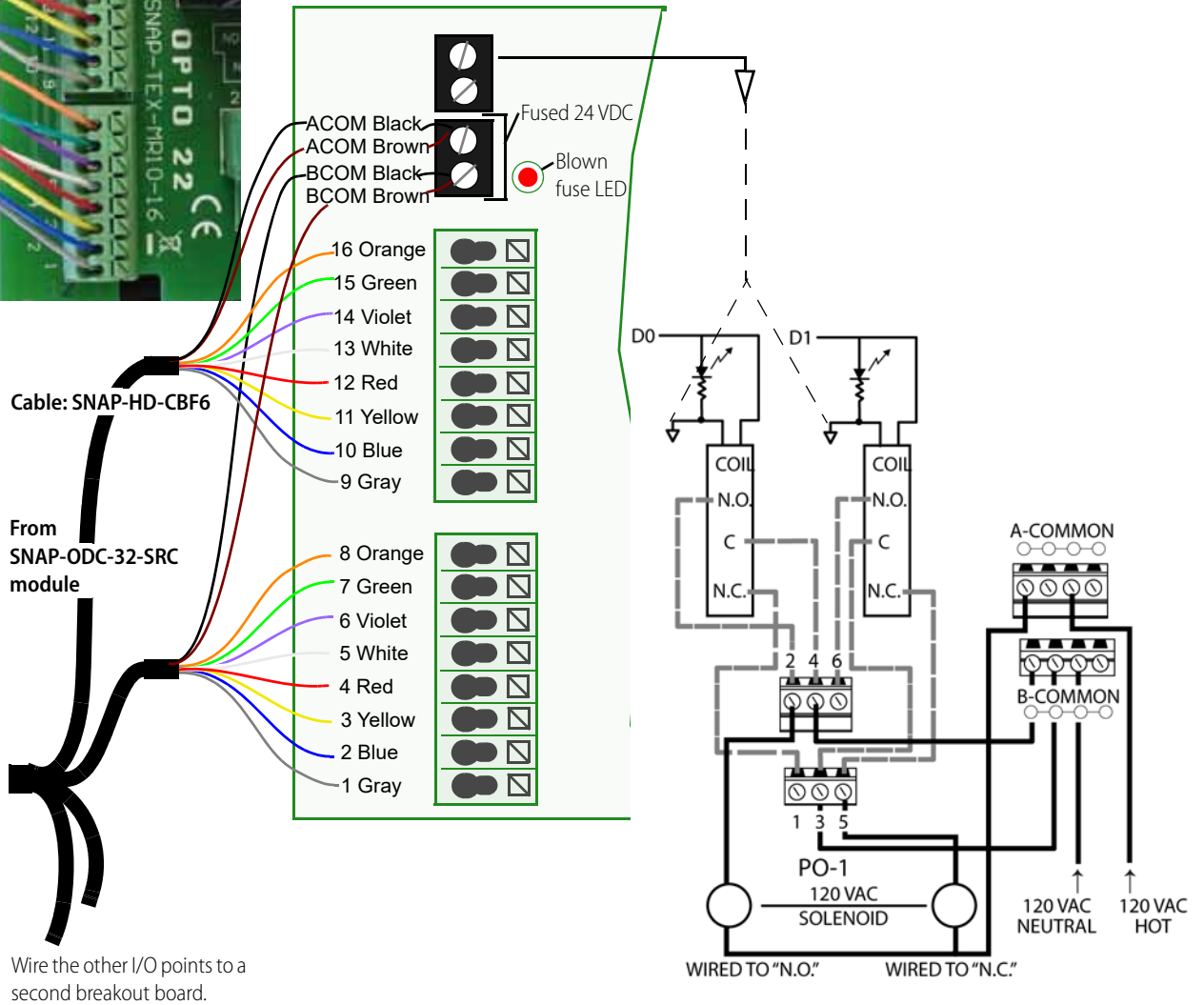

Field wiring—For normally open (N.O.) or normally closed (N.C.).

NOTE: In the above diagram, gray dashed lines represent traces on the board itself. Black solid lines represent wiring.

WIRING: 32-POINT DIGITAL OUTPUT MODULE TO SNAP-TEX-MR10-16C BOARD

For 32-point sourcing modules only (SNAP-ODC-32-SRC or SNAP-ODC-32-SRC-FM).

Use two breakout boards with one module and one SNAP-HD-G4F6 cable (each cable has two header connectors).

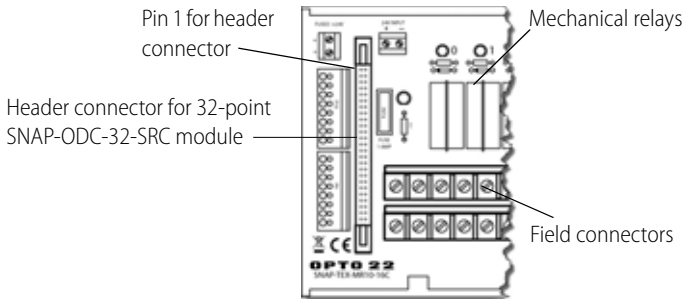

SNAP-TEX-MR10-16C breakout boards

Two breakout boards are required for the 32 points on the module.

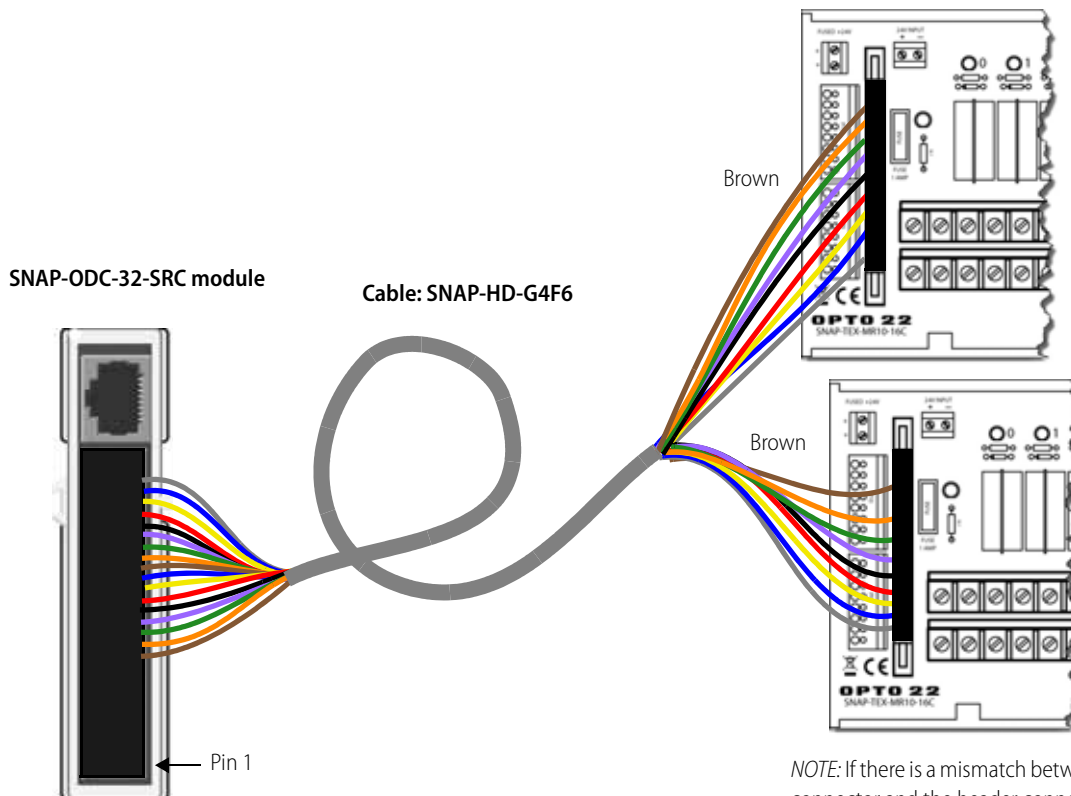

NOTE: If there is a mismatch between the cable connector and the header connector, please contact Opto 22 Product Support.

WIRING: 32-POINT ANALOG CURRENT MODULE TO SNAP-AIMA-HDB BOARD

This diagram cannot be used with self-sourcing transmitters.
Use this diagram only with loop power (2-wire) negative common devices.

For self-powered (4-wire) devices, use a SNAP-AIV-HDB board and the wiring diagram on [page 52](#) (for negative common devices) or [page 53](#) (for positive common devices).

See "Working with Module Values" on [page 22](#).

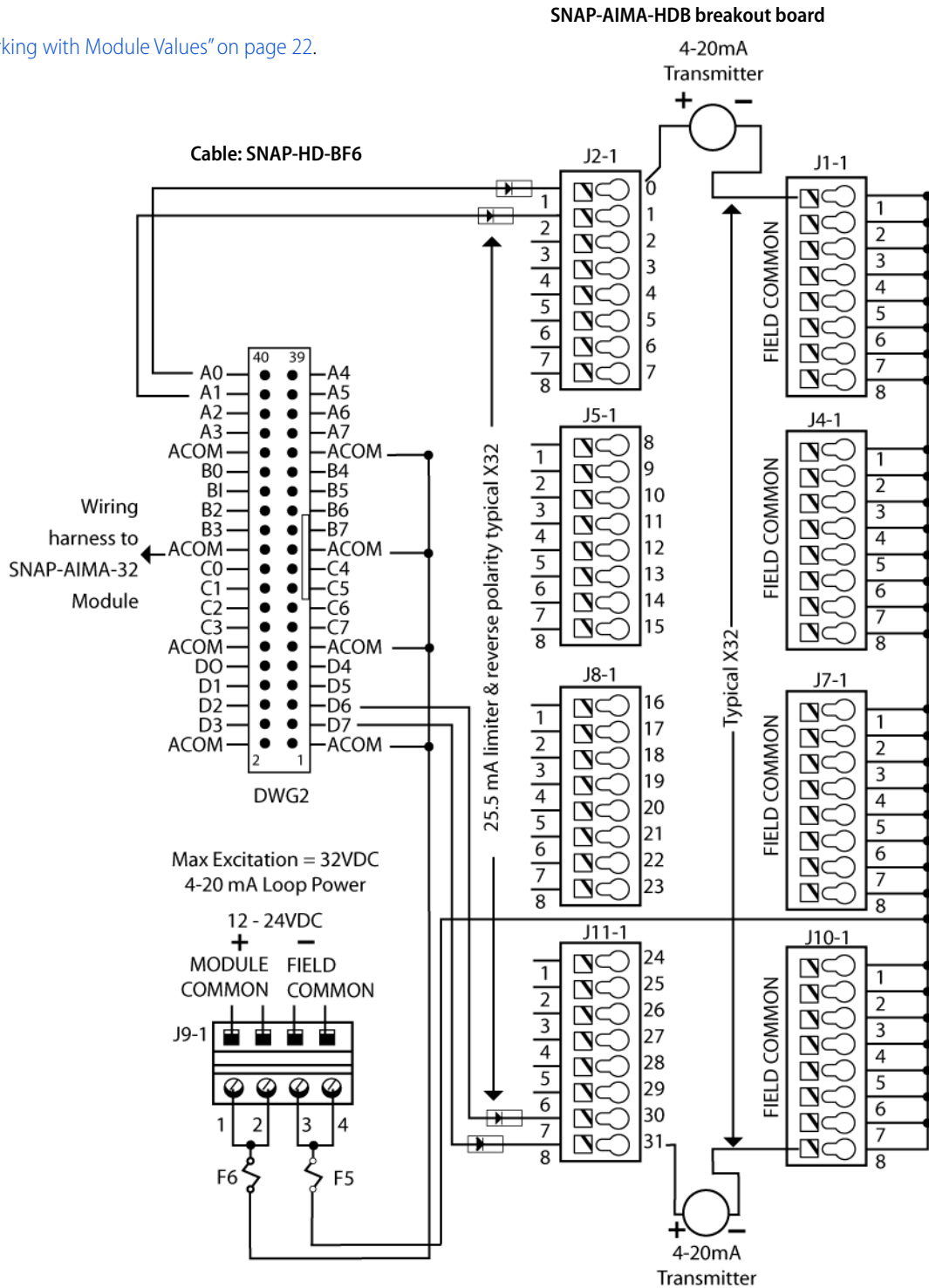

WIRING: 32-POINT ANALOG MODULE TO SNAP-AIV-HDB BREAKOUT BOARD

Self-powered devices with negative common

Use this diagram for a SNAP-AIV-32 module or for a SNAP-AIMA-32 module when the module connects to self-powered (4-wire) devices that share a negative common connection.

See the module's data sheet for more information.

See "Working with Module Values" on page 22.

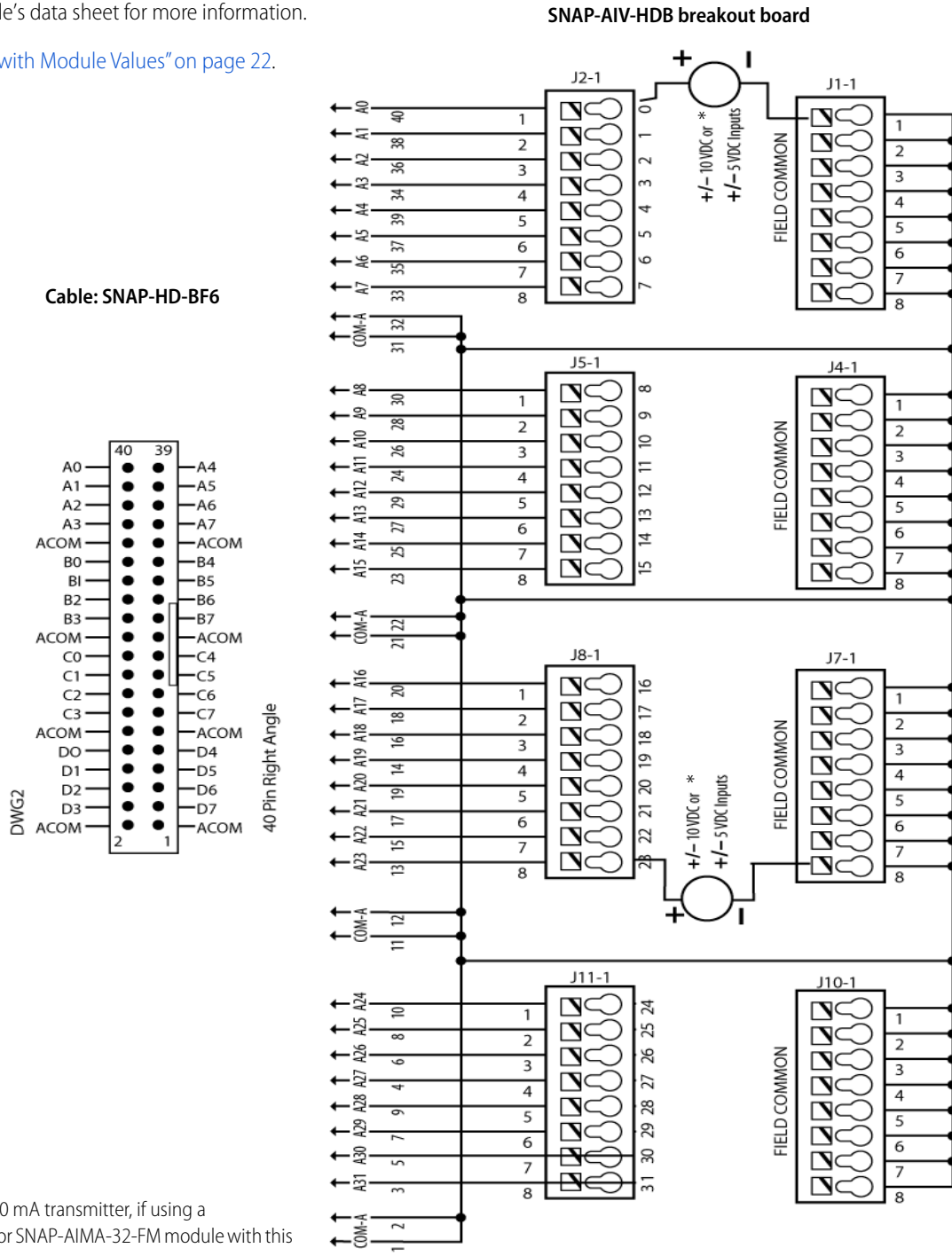

* Or 4-wire, 4–20 mA transmitter, if using a SNAP-AIMA-32 or SNAP-AIMA-32-FM module with this rack

WIRING: 32-POINT ANALOG MODULE TO SNAP-AIV-HDB BREAKOUT BOARD

Self-powered devices with positive common

Use this diagram for a SNAP-AIV-32 module or for a SNAP-AIMA-32 module when the module connects to self-powered (4-wire) devices that share a positive common connection.

See the module's data sheet for more information.

See "Working with Module Values" on page 22.

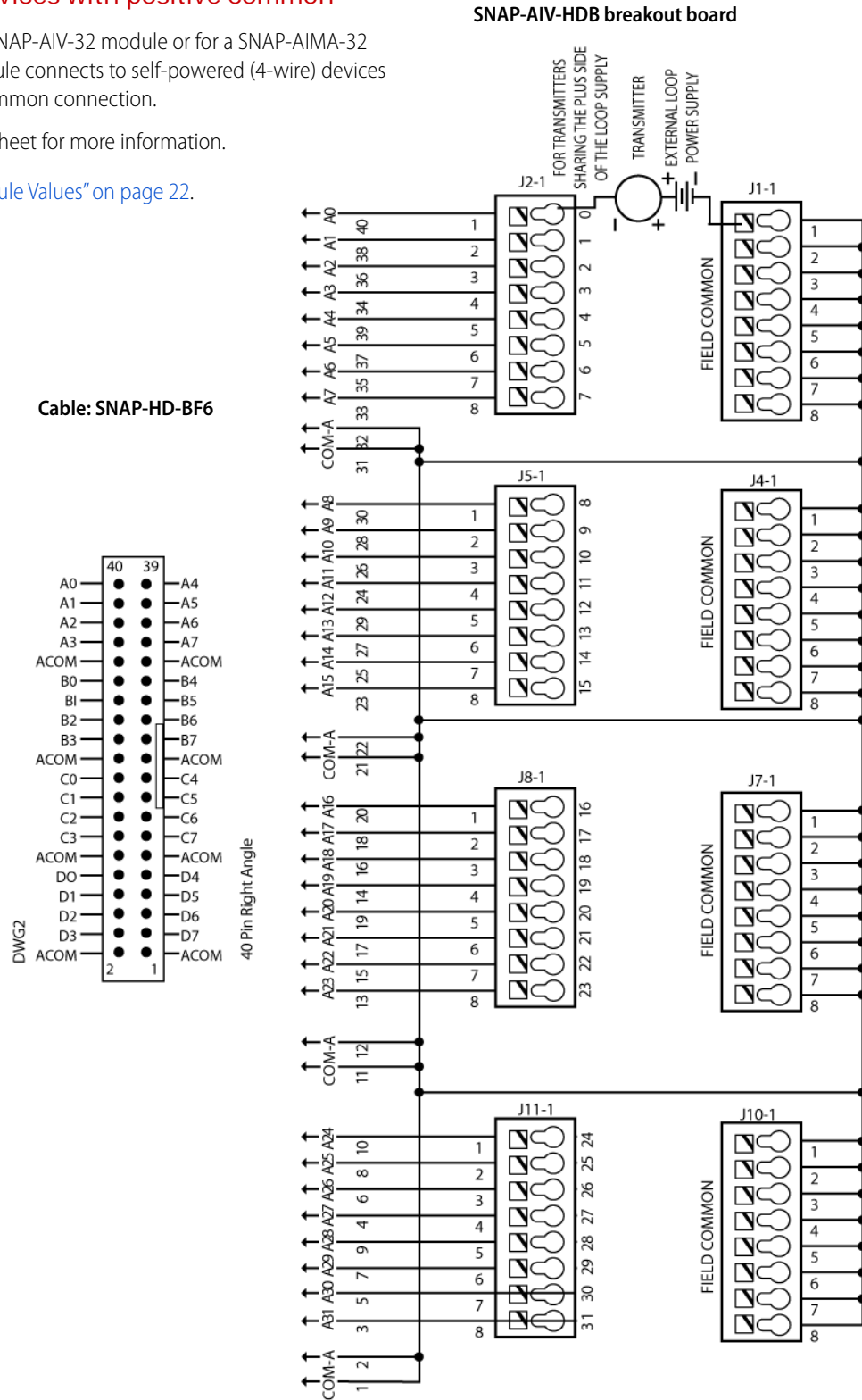

PRODUCTS

Opto 22 develops and manufactures reliable, easy-to-use, open standards-based hardware and software products. Industrial automation, process control, remote monitoring, data acquisition, and industrial internet of things (IIoT) applications worldwide all rely on Opto 22.

groov RIO®

groov RIO edge I/O offers a single, compact, PoE-powered industrial package with web-based configuration and IIoT software built in, support for multiple OT and IT protocols, and security features like a device firewall, data encryption, and user account control.

Standing alone, groov RIO connects to sensors, equipment, and legacy systems, collecting and securely publishing data from field to cloud. Choose a universal I/O model with thousands of possible field I/O configurations, with or without Ignition from Inductive Automation®, or a RIO EMU energy monitoring unit that reports 64 energy data values from 3-phase loads up to 600 VAC, Delta or Wye.

You can also use groov RIO with a Modbus/TCP master or as remote I/O for a groov EPIC system.

groov EPIC® System

Opto 22's groov Edge Programmable Industrial Controller (EPIC) system gives you industrially hardened control with a flexible Linux®-based processor with gateway functions, guaranteed-for-life I/O, and software for your automation and IIoT applications.

groov EPIC Processor

The heart of the system is the groov EPIC processor. It handles a wide range of digital, analog, and serial functions for data collection, remote monitoring, process control, and discrete and hybrid manufacturing.

In addition, the EPIC provides secure data communications among physical assets, control systems, software applications, and online services, both on premises and in the cloud. No industrial PC needed.

Configuring and troubleshooting I/O and networking is easier with the EPIC's integrated high-resolution color touchscreen. Authorized users can manage the system locally on the touchscreen, on a monitor connected via the HDMI or USB ports, or on a PC or mobile device with a web browser.

groov EPIC I/O

groov I/O connects locally to sensors and equipment. Modules have a spring-clamp terminal strip, integrated wireway, swing-away cover, and LEDs indicating module health and discrete channel status. groov I/O is hot swappable, UL Hazardous Locations approved, and ATEX compliant.

groov EPIC Software

The groov EPIC processor comes ready to run the software you need:

- Programming: Choose flowchart-based PAC Control, CODESYS Development System for IEC61131-3 compliant programs, or secure shell access (SSH) to the Linux OS for custom applications
- Node-RED for creating simple IIoT logic flows from pre-built nodes
- Efficient MQTT data communications with string or Sparkplug data formats
- HMI: groov View to build your own HMI viewable on touchscreen, PCs, and mobile devices; PAC Display for a Windows HMI; Node-RED dashboard UI
- Ignition or Ignition Edge® from Inductive Automation (requires license purchase) with OPC-UA drivers to Allen-Bradley®, Siemens®, and other control systems, and MQTT communications



Older products

From solid state relays, to world-famous G4 and SNAP I/O, to SNAP PAC controllers, older Opto 22 products are still supported and working hard at thousands of installations worldwide. You can count on us for the reliability and service you expect, now and in the future.

QUALITY

Founded in 1974, Opto 22 has established a worldwide reputation for high-quality products. All are made in the U.S.A. at our manufacturing facility in Temecula, California.

Because we test each product twice before it leaves our factory rather than testing a sample of each batch, we can afford to guarantee most solid-state relays and optically isolated I/O modules for life.

FREE PRODUCT SUPPORT

Opto 22's California-based Product Support Group offers free technical support for Opto 22 products from engineers with decades of training and experience. Support is available in English and Spanish by phone or email, Monday–Friday, 7 a.m. to 5 p.m. PST.

Support is always available on our website, including [free online training](#) at OptoU, how-to [videos](#), [user's guides](#), the Opto 22 KnowledgeBase, and [OptoForums](#).

PURCHASING OPTO 22 PRODUCTS

Opto 22 products are sold directly and through a worldwide network of distributors, partners, and system integrators. For more information, contact Opto 22 headquarters at **800-321-6786** (toll-free in the U.S. and Canada) or **+1-951-695-3000**, or visit our website at www.opto22.com.